



INSTALLATION, SERVICE AND MAINTENANCE INSTRUCTIONS



***Electric multi-turn actuators
MO 3, MO 3.3, MO 3.4, MO 3.5***

TEST CERTIFICATE

ELECTRIC PART-TURN ACTUATOR MO 3, MO 3.4, MO 3.5	
Type number	Power supply V Hz
Serial number	Switching-off torque Nm
Production year	Adjusted switching - off torque Nm
Wiring diagram	Operating speed min ⁻¹
.....	Adjusted number of revolutions
.....	Transmitter (potentiometer)
Warranty period months	Input operating signal
Serial number of electric motor	
Serial number of transmitter	
Serial number of position controller	
Tests made in accordance with TP 74 1007 00	
Tests made by	
Date	Signature and stamp

COMPLETENESS CERTIFICATE

Used valve	
Assembled by: Firm	
Name.....	
Warranty period months	
Date	Signature and stamp.....

INSTALLATION CERTIFICATE

Location	
Installed by: Firm	
Name	
Warranty period..... months	
Date	Signature and stamp.....

Please read these instructions carefully before mounting and operating the actuator!

Preventive and safety-measures applied on the actuator can not offer required safety level till the actuator and its safety systems are not applied by required and described way and if installation and maintenance is not applied according to applicable instructions and rules!

Contents

1.	Generally.....	2
1.1	Purpose and application of the product.....	2
1.2	Safety instructions.....	2
1.3	Data specified on electric actuator.....	3
1.4	Warranty conditions.....	3
1.5	Under-guarantee and after-guarantee service.....	4
1.5.1	Lifetime of actuators.....	4
1.5.2	Lifetime of single-phase electric motors:.....	4
1.6	Operation conditions.....	5
1.6.1	Product location and operation position.....	5
1.6.2	Operation environment.....	5
1.6.3	Power supply and operating mode.....	6
1.7	Conservation, packing, transport, storing and unpacking.....	7
1.8	Assessment of the product and packaging and removal of contamination.....	7
2.	Description, function and technical parameters.....	8
2.1	Description and function.....	8
2.2	Technical data.....	12
2.2.1	Mechanical connection.....	16
2.2.2	Electric connection.....	16
3.	Installation and dismantling of actuator.....	17
3.1	Installation.....	17
3.1.1	Mechanical connection to the armature.....	17
3.1.2	Electric connection to the network, respectively control system.....	18
3.2	Disassembly.....	19
4.	Adjusting.....	20
4.1	The torque unit adjustment (Fig. 4 and 5).....	20
4.2	Position switches adjustment (S3(S13),S4(S14) (Fig. 6).....	21
4.3	Signaling switches adjustment (S5,S6) (Fig. 8).....	23
4.4	Position indicator adjustment (Fig.8).....	23
4.5	Adjustment of resistant transmitter (Fig.9).....	24
4.6	Adjustment of the Electronic Position Transmitter (EPV) - the Resistive Transmitter (Potentiometer) with the Converter PTK 1.....	25
4.6.1	EPV – the 2-wire version (Fig. 10).....	25
4.6.2	EPV – 3-wire version (Fig. 11).....	25
4.7	Adjustment of Capacitive Transmitter CPT1/A (Fig.12).....	26
4.8	Adjustment of position controller (Fig. 13).....	28
4.8.1	Setting of controller.....	28
4.8.2	Watching operation and error states.....	29
4.9	Local electric control (Fig.14).....	30
5.	Service, maintenance and troubleshooting.....	30
5.1	Operation.....	30
5.2	Maintenance – scope and regularity.....	30
5.3	Troubleshooting.....	32
6.	Accessories and spare parts.....	32
6.1	Accessories.....	32
6.2	The list of spare parts.....	32
7.	Enclosures.....	33
7.1	Wiring diagrams.....	33
7.2	Switch operation chart.....	37
7.3	Dimension drawings and mechanic connections.....	38
7.4	Guarantee service check report.....	52
7.5	Post guarantee service check report.....	53
7.6	Commercial representation.....	54

The Installation, Service and Maintenance Instructions are drawn up according to requirements of EC Executive Nr. 2006/42/EC "Uniform requirements for machines and devices from the point of view of safety and health care", to save life and health of users and to avoid material damages and exposure environment to danger.

1. Generally

1.1 Purpose and application of the product

Electric multi-turn actuators (hereafter referred to as **EA**), types **MO 3, MO 3.3, MO 3.4 resp. MO 3.5** (hereinafter referred as **MO**) only are high performance electro-mechanical products, designed for direct assembly on controlled devices (regulating bodies - valves, etc.). EA are designed for remote control of armatures by reversing rotary motion in both directions of their movement. EA **MO** with controller types are provided for automotive control of regulating bodies. They can be equipped with means of measuring and control of technological processes where an unified analogue direct current or voltage signal is an information bearer on their input and/or output. They can be used in heating, energy, gas, air-conditioning and other technological systems, which they are suitable for, regarding their features. They are connected with controlled devices with a flange and coupling shape according to ISO 5210, DIN 3338, or in accordance with GOST R 55510.



1. *It is prohibited to use EA as lifting device!*
2. *The option of switching EA via semi conductive trigger switches must be consulted with the actuator manufacturer.*
3. *Switching of actuator by a semiconductor switches have to be consulted with producer.*

1.2 Safety instructions



EA of MO types are reserved technical devices with higher rate of danger, with possibility of installation in areas specially danger regarding casualties caused by electric current.

Electric actuators are according to directive LVD 2014/35/EU and standard EN/IEC 61010-1:2010 assigned for installation category II (overvoltage category).

Product influence to environment

Electromagnetic compatibility (EMC): the product complies with the requirements of the Directive 2014/30/EU of the European Parliament and of the Council on the approximation of the laws the Member States relating to the electromagnetic compatibility and with the requirements of standards as well EN/IEC 61000-6-4+A1, EN/IEC 61000-6-2, EN/IEC 61000-3-3 and EN/IEC 61000-3-2 within valid edition.

Vibrations caused by the product: product influence is negligible.

Noise produced by the product: during operation the noise level A at the service area can be at least 90 dB (A).

Environment hazard: the product involves a mineral oil fill harmful for water species that is capable to generate long-time lasting adverse effects in water environment. When handling and operating the product don't allow oil to escape in environment. An increased care must be given when the product is operated near to water sources.

Requirements for professional qualification of people performing installation, service and maintenance



Electric connection can be performed only by an acquainted person, i.e. an electrical engineer with professional education of electrical engineering at an apprentice school or a technical school (secondary, complete secondary or university education) and whose qualification was verified by an educational facility authorized to verify professional qualification.

Instructions for stuff training



Service can be performed only by workers professionally qualified and trained by the producer or contracted service centre.

Warning for safety use

Product protection

EA MO does not have own short-circuit protection, therefore there must be included suitable protective device into the supply power (circuit breaker, or fuse), which serves at the same time as main switch.

Type of equipment from a connection point of view: The equipment is designed for permanent connection.

1.3 Data specified on electric actuator

Nameplate:

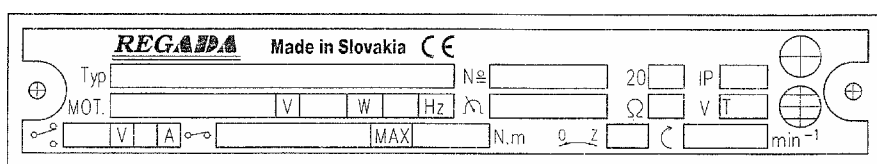

Warning plate:



Nameplate contains the basic data concerning identification, performance and electricity: indication of producer, type, serial number, max. load torque and switching-off torque, operating speed, protection code, revolutions, supply voltage and current.

Graphic symbols on electric actuator

The graphic symbols used on electric actuator substitute the text messages. Some of them are in accordance with EN ISO 7010, ISO 7000 and IEC 60417.



Dangerous voltage

(EN ISO 7010-W012)



CAUTION! ¹⁾

(EN ISO 7010-W001)

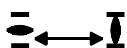

Stroke of the electric actuator



Switching-off torque



Manual control

(0096 ISO 7000)



Protection terminal

(5019 IEC 60417)

¹⁾ See. chapter 3.1.2

1.4 Warranty conditions

The supplier is responsible for completeness of the delivery and guarantees these specifications of the product which are stated in the Contract.

The supplier is not responsible for any deterioration of parameters caused by the customer during storage, unauthorized installation or improper operation.

1.5 Under-guarantee and after-guarantee service

Our customers are provided with professional service of our firm in installation, operation, service, maintenance, revision and help in troubleshooting for all our products.

Under-guarantee service is performed by the service department of the production plant, or by a contracted service centre according to a written claim.

In case of occurring of any fault please let us know it and state:

- type code
- serial number
- ambient parameters (temperature, humidity...)
- duty cycle including frequency of switching
- type of switching-off (position or torque)
- set switching-off torque
- type of fault - description of claimed fault
- it is recommended to place also Installation certificate.

It is recommended to have **after-guarantee service** performed by the service department of the production plant, or by a contracted service centre.

1.5.1 Lifetime of actuators

The lifetime of an electric actuator (EA) is at least 6 years.

EA used for closing mode (closing valves) comply with the requirements for at least **15,000 working cycles** (cycle C – O – C at 30 revolutions per operating stroke:for multi-turn EA)

EA used for regulating/modulating operation (control valves) comply with the below stated numbers of **operating hours** at the total number of 1 million start-ups:

Switching frequency				
max. 1,200 [h ⁻¹]	1,000 [h ⁻¹]	500 [h ⁻¹]	250 [h ⁻¹]	125 [h ⁻¹]
Minimal lifetime expectancy – number of operating hours				
850	1,000	2,000	4,000	8,000

Time of **net operation** is min. 200 hours, max. 2,000 hours.

Lifetime at operating hours depends on loading and switching frequency.

Note : High switching frequency does not ensure better regulation. Setting of regulation parameters should be therefore made with the inevitably necessary switching frequency needed for the process in question

1.5.2 Lifetime of single-phase electric motors:

There are single-phase electric motors from SIEMENS - range ILF7 ... with run and start capacitor built-in version of actuators with single phase electric motor. The manufacturer guarantees 100.000 starts for the 4 pole electric motors (approx. 1400 rpm/min).

Attention: Reversing of actuators in design with those single phase motors is possible only after the total stop of the output of actuator. Otherwise, there may be a continuation of the movement of the output of actuator, even after the reversing process in the direction what was before the reversing process. Maximum number of motor stop can be 500 per hour.

Estimated duty cycles of actuators equipped with those electric motors feel free to consult with the Sales department of REGADA s.r.o.

1.6 Operation conditions

1.6.1 Product location and operation position

- Electric actuators may be installed and operated in enclosed locations of industrial facilities with no temperature and moisture regulation, protected from direct climatic effects (such as direct sunlight). Moreover, special “marine” versions may be used in waste water treatment applications, water management, selected chemical applications, tropical environments and coastal areas.
- Electric actuators must be placed with access to the manual control wheel (4) (Fig.1), to the cover of control box (6), to control box (M4), to bushings (7).
- Installation and operation of actuators is possible in either position, while motor axis is in horizontal position; variance of motor axis from horizontal plane can be $\pm 15^\circ$. Common position is the one with vertical position of exit part axis and control box above.

Warning:



When the EA is installed in open air, **it must be** sheltered lightly to protect is against direct effects of atmosphere.

When installed in the areas with relative humidity more than 80%, in open air under a shelter is needed to connect the space heater directly – without a thermal switch.

1.6.2 Operation environment

According to valid standard IEC 60 721-2-1, there are delivered these versions of electric actuators:

- 1) Version „**temperate**“ for climate temperate
- 2) Version „**cold**“ - for climate cold
- 3) Version „**tropical**“ for climate tropical and dry
- 4) Version „**marine**“ for climate marine.

In accordance with IEC 60 364-1, IEC 60 364-5-51 and IEC 60 364-5-55 within valid edition EA have to resist external effects and operate reliably:

In the conditions of the following types of environment:

- warm mild to very hot dry with temperature in range -20°C to $+60^\circ\text{C}$ AA 3+AA 6*
- cold, warm mild to hot dry with temperatures -50°C to 40°C AA 2+AA 5*

in industrial environment: at temperatures stated above

- with relative humidity 10 to 100 %, including the condensation of up to 0,029 kg water content per 1 kg of dry air at 27°C , at above stated temperature AB 3+AB 6*
- with relative humidity 5 to 100 %, including the condensation of up to 0,025 kg water content per 1 kg of dry air at 27°C , at above stated temperature AB 2+AB 5*
- with height above sea level 2 000 m, with barometric pressure range 86 to 108 kPa AC 1*
- with spraying or jet water from all directions–(protection enclosure IP x5) AD 5*
- with strong dustiness – with a possibility of influences of inflammable, non-conducted and non-explosive dust; the middle layer of dust; the dust drop more than 35 but not more than 350 mg/m^2 per day (products with protection enclosure of IP 5x) AE 5*
- with shallow dive – (product in protection IP x 7) AD 7*
- with strong dustiness – with a possibility of influences of inflammable, non-conducted and non-explosive dust; the middle layer of dust; the dust drop more than 350 but not more than 1000 mg/m^2 per day (products with protection enclosure of IP 6x) AE 6*
- with atmospheric occurrence of corrosive and pollution media (with high degree of atmosphere corrosive aggressiveness); important presence of corrosive pollution AF 2*
- with permanent exposure of big amount of corroding or contaminated chemicals and salt fog in execution for sea environment , for sewage water disposal plant and some chemical AF 4*
- with a possibility of influences of mechanical stress:
 - medium sinusoid vibrations with frequency in range 10 up to 150 Hz, with shift amplitude of 0,15 mm for $f < f_p$ and acceleration amplitude $19,6\text{ m/s}^2$ for $f > f_p$; (transition frequency f_p is from 57 up to 62 Hz) AH 2*
 - medium impacts, shocks and vibrations AG 2*

- with serious danger of plants and moulds growing AK 2*
- with serious danger of animals occurrence (insects, birds, small animals)AL 2*
- with detrimental influence of radiation:
 - of stray current with intensity of magnetic field (direct and alternating of power supply frequency) to 400 A.m⁻¹AM 2-2*
 - of sun radiation with intensity > 500 a ≤ 700 W/m² AN 2*
- with effects of medium seismic activity with acceleration > 300 Gal ≤ 600 Gal AP 3*
- with indirect danger of storm activityAQ 2*
- with fast moving of air and strong windsAR 3* , AS 3*
- with persons frequent touching earth potential (persons often touch conductive parts or they stand on the conductive basement) BC 3*
- without any danger media with object BE 1*

* Marking in accordance with IEC 60364-1, IEC 60 364-5-51 and IEC 60 364-5-55 within valid edition

1.6.3 Power supply and operating mode

Supply voltage:

Electric motorY/Δ; 400 / 230V AC respectively Y/Δ; 380 / 220V AC; 230/220 V AC $\pm 10\%$ (other - after agreement with manufacturer)

Control 230 V AC $\pm 10\%$

Supply voltage frequency 50/60* Hz $\pm 2\%$

* For 60Hz frequency is operating speed increased by 1, 2 multiple.

Duty cycle (according to EN/IEC 60034-1.8):

EA MO are designed for **remote control**:

- short-time operation **S2-10 min**
- intermitted operation **S4-25%, 6 up to 90 cycles per hour.**

EA MO with controller are designed for **automatic regulation**:

- intermitted operation **S4-25%, 90 up to 1200 cycles per hour.**

1.7 Conservation, packing, transport, storing and unpacking

Surfaces without surface treatment are treated by conservation preparation MOGUL LV 2-3 before packaging.

Conservation is not necessary if the following storage conditions are complied with:

- Storage temperature: -10 to +50 °C
- Relative air humidity max.80 %
- Electric actuators and their accessories must be stored in dry, well ventilated covered spaces, protected against impurities, dust, soil humidity (by placement to racks, or on pallets), chemicals and foreign interventions
- There shall be no corrosive gases present in the storage areas.

The EA MO are delivered in solid packages guaranteeing resistance in accordance with EN/IEC 60 654 -1 and EN/IEC 60 654-3.

Package is a box. Products in boxes is possible to load on the pallets (pallet is returnable). On the outer side of the package is stated:

- manufacturer label,
- name and type of product,
- number of pieces,
- other data – notices and stickers.

The forwarder is obliged to secure packed products, loaded on transportation means, against self-motion; if open transportation means are used, to secure their protection against atmospheric precipitations and splashing water. Displacement and securing of products in transportation means must provide their stable position, exclude the possibility of their inter-collision and their collision with the vehicle walls.

Transportation can be executed by heatless and non hermetic spaces of transportation vehicles with influences within the range:

- temperature: -25° C up to +70° C (a strange version – 45 ° C up to + 45 ° C)
- humidity : 5 up to 100 %, with max. water content 0.029 kg/kg of dry air
- barometric pressure 86 up to 108 kPa.

Upon receiving of EA examine, if during transportation, resp. storing did not come to its damage. At the same time verify, if the data on the labels corresponds to accompanying documentation and purchase-sale contract / order. Eventual discrepancies, faults and damages should be reported without any delay to supplier.



Electric actuators and their accessories must be stored in dry, well ventilated covered spaces, protected against impurities, dust, soil humidity (by placement to racks, or on pallets), chemicals and foreign interventions, at ambient temperature from -10°C up to +50°C and at relative air humidity max. 80 %.

Warning:

1. *It is not acceptable to store EA outdoors, or in areas not protected against direct climate influence!*
2. *It is not recommended to set up the electric actuator manually without mechanic connection with armature. The electric actuator does not have mechanic restriction of working stroke in terminal positions and therefore can after exceeding of the stroke come to mistuning of parameters set up by production plant.*
3. *Eventual damages to surface finish remove without delay – thus preventing damage by corrosion.*
4. *If storing takes longer than 1 year, it is necessary to inspect lubrication fillings before putting EA into operation.*
5. *Assembled EA, but not put into operation is necessary to protect by the equivalent method as during storage (for example suitable protective cover).*
6. *After assembly to the armature in free and wet areas, or in areas with temperature changes, connect without delay heating resistor – thus preventing damages caused by corrosion from liquefied water in the control area.*
7. *Excessive preserving grease remove just before putting EA into operation.*

1.8 Assessment of the product and packaging and removal of contamination

The product and its package are made of recycling materials. Do not throw the single parts of the package and of the product after their life but sort them according to instructions in corresponding executives or regulations of environment protection, and allow their recycling.

The product, however, contains a mineral oil fill dangerous for the environment. Please avoid oil leak into the environment at its disposal.

2. Description, function and technical parameters

2.1 Description and function

Electric multi-turn actuators **MO** consist of these modules (Fig.1):

- Module M 1 – electric-motor
- Module M11 – countershaft transmission with rotary hold
- Module M 3 – force transmission with additional gear box and manual control
- Module M 4 – control box

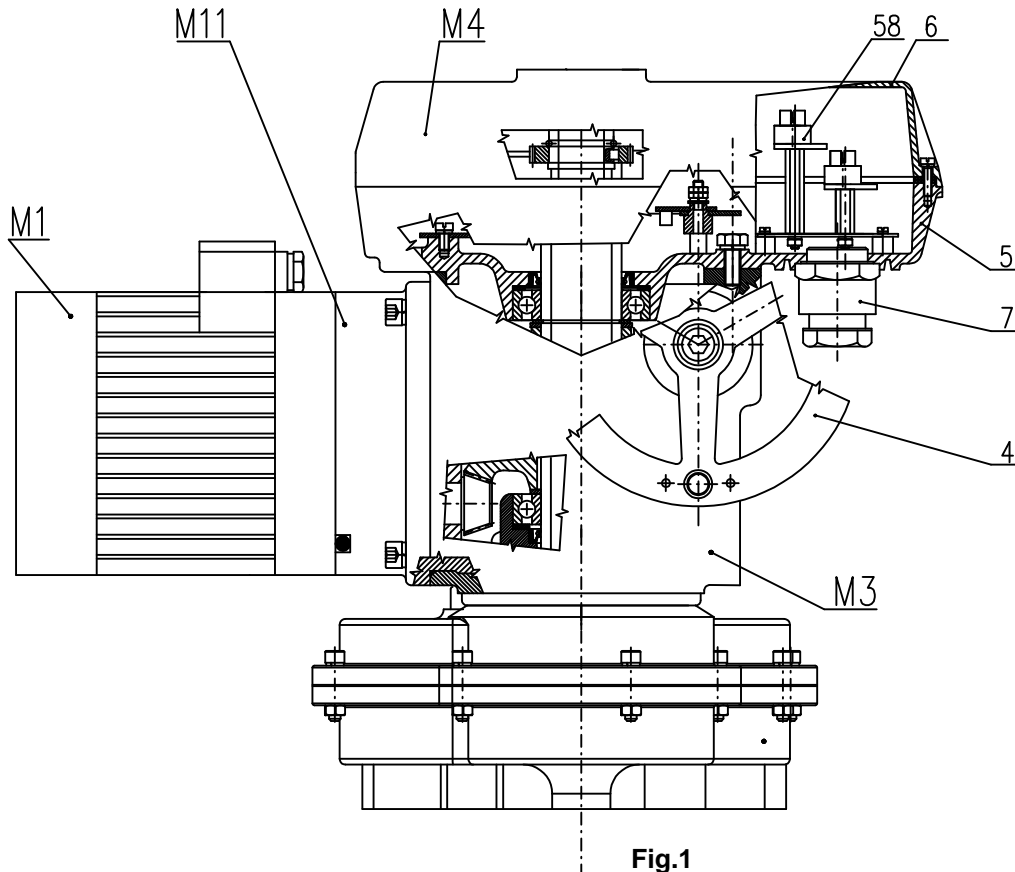

Fig.1

Module M1 – electric-motor

- Three-phase asynchronous electric-motor

Module M11 – countershaft transmission with rotary hold

Countershaft transmission performs reduction of revolutions of electric - motor to specified transmission value. Countershaft transmission consists of two or three pairs of spur meshing toothed wheels and is terminated by bevel pinion, which meshes into bevel gear of transmission from module M3.

Rotary hold substitutes motor mechanic brake and allows manual control of EA.

Modul M 3 – force transmission with manual control (Fig. 2)

The set is stored in box (1). Gears are centrally positioned on output shaft (3) and creates independent assembly unit. Wheel rim (44) with inner gearing provides transfer between electric motor pinion and output shaft. In upper part is located the worm (2) for torque sensing and manual control, which is used for positioning of controlled equipment during electric power breakdown. Positioning is executed manually by hand wheel (4). The worm is suspended and a thrust created by output shaft torque axially shifts the worm against spring tension. The worm movement is transferred by the fork with pin through a shaft (45) joined to control box. Movement of the worm is proportional to the load torque. The fork meshes into circumferential notch, allowing rotary motion of manual wheel, therefore manual control in every operating status. On the box (1), (across to manual wheel) are three bosses with threaded openings allowing assembly of electric actuator on the wall, or supporting construction.

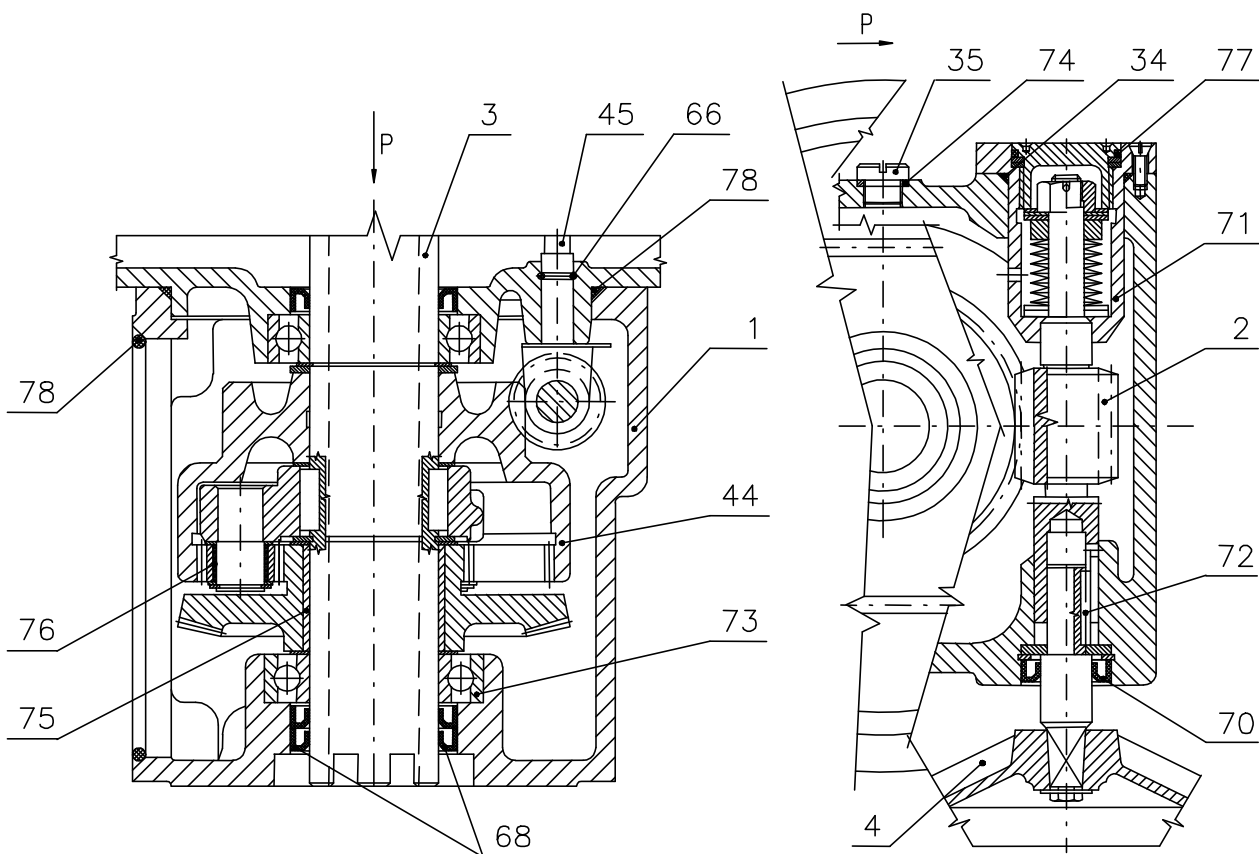

Fig.2

Module M 4 – control box (Fig. 1)

Control box is in upper part of electric actuator and forms individual function unit. The top part is formed by the cover with opening and monitoring window of position indicator.

The bottom part of control box closes the box of force transmission and forms carrying part of control plate Fig.3.

On mounting base (46) of control plate are fixed these functional blocks:

- position unit (11)
- signalling unit with gear unit (12)
- torque unit (9)
- transmitter unit (33) (according to EA specification)
- heating resistor (16) with thermal switch (15)
- controller (only for EA **MO** with controller) (14)
- reversing contactors (13) (according to EA specification)
- electrical connections by means of terminals (58) (Fig.1) situated within terminal box, and cable bushings (7) (Fig.1), or connector with cable bushings
- local electric control module (Fig.14) (according to EA specification) is situated in terminal box and connected with control board.

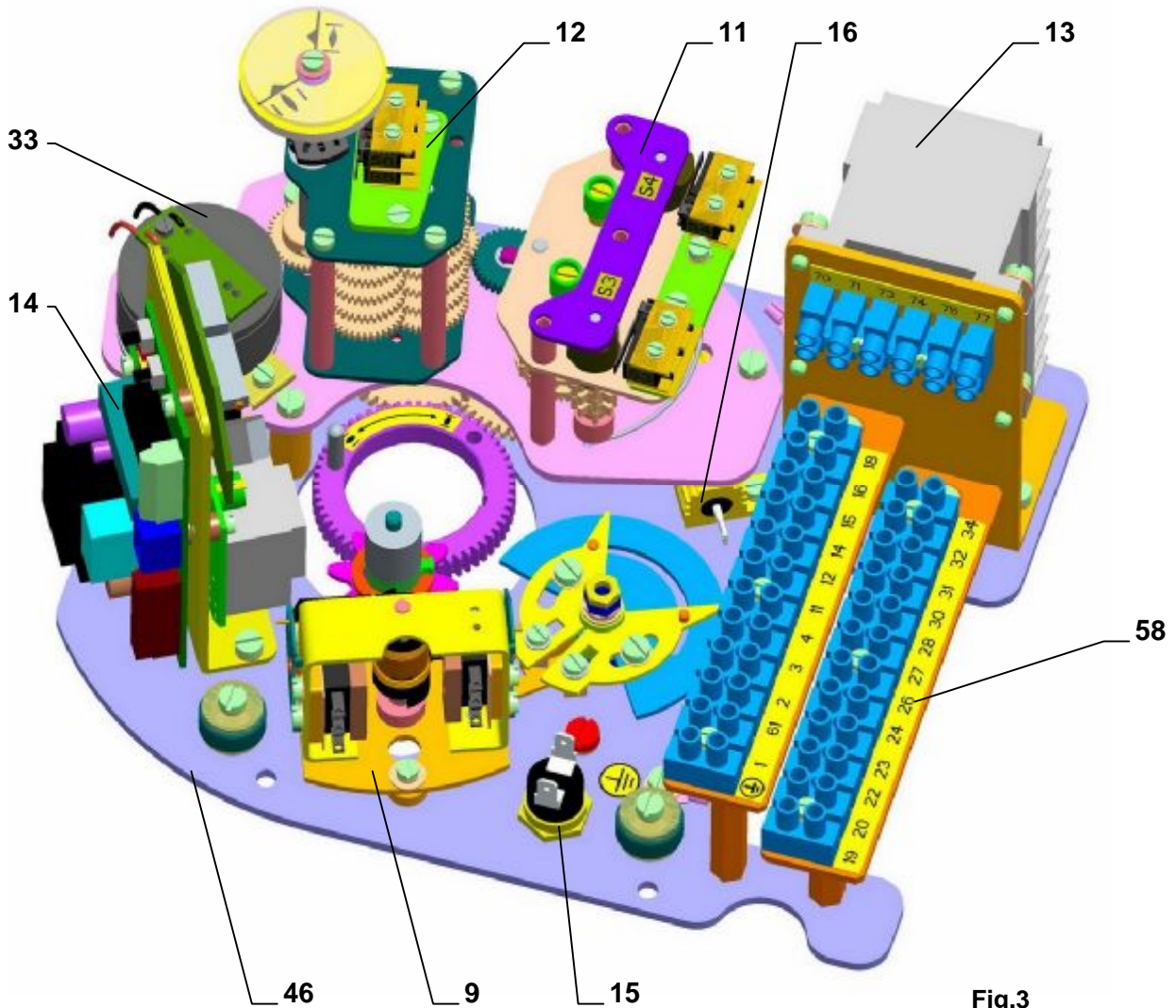

Fig.3

Position unit

EA is equipped with a position step unit that provides for limiting the EA end positions with electric control by means of S3, S4 position switches. The drive for the position unit is derived from EA output shaft by means of idle gears.

Signalling unit with gear unit

Signalling unit provides for closing S5, S6 position switches before the end positions. The drive for the signalling unit is derived from EA output shaft by means of a gear unit on which an appropriate working revolutions range is to be set by an adjustable gear wheel.

Torque unit (Fig. 4 and 5) is composed of three functional sub-units:

- torque disk (Fig. 4)
- torque unit (Fig. 5)
- locking mechanism (82) (Fig. 5)

Torque disk (Fig. 4) is assembled on torque shaft (45) discharged from power transmission (Fig.2). Steer angle of torque disk is proportional to torque moment of output shaft (3) of electric actuator. Its magnitude can be adjusted by segments (17) and by shifting of backstops (18). Achieved torque moment value is from torque disk transferred on torque unit (9) by means of torque lever (42).

Remark:

The gauge marks on the scales do not indicate direct value switching – off torque; they are used only for more detailed orientation during adjusting its magnitude within marked MIN. and MAX. disconnecting value for given make without testing device for thrust measurement.

Torque unit (Fig.5) consists of a carrier, on which are displaced switches S1 (20) and S2 (21). On the shaft (23) are mounted disconnecting levers (24), keeping switches pressed by spring tensions until a moment when the shaft is turned out of the mesh of torque disconnection.

Locking mechanism (82) (Fig.5) provides locking of torque disconnection usually to 1 or 2 turns after reversing of electric actuator. After elapsing of adjusted revolution will torque unit acquire its original function.

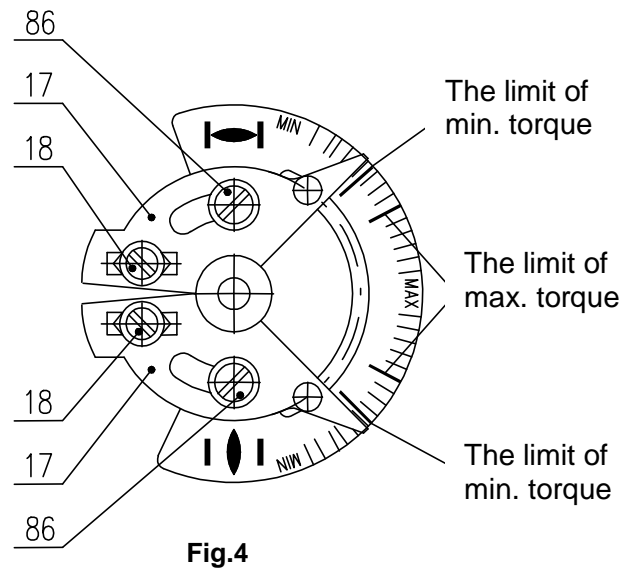

Fig.4

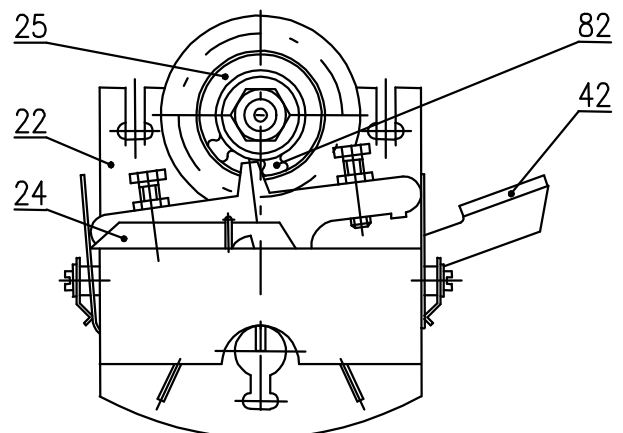
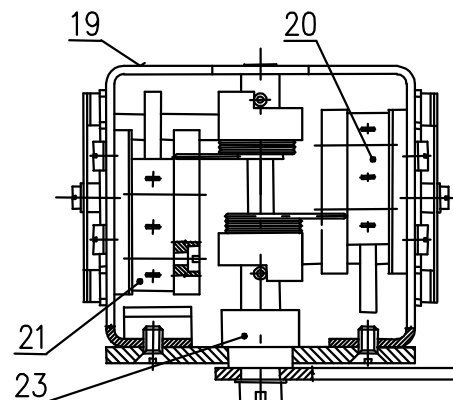

Fig.5

Transmitter unit

EA can involve also a position transmitter and output signal of which depends on the customer's specification. This transmitter provides for continuous transfer of output member position information, eventually, in the variant with regulator as a feedback for controller.

Heating resistor with thermal switch

EA is equipped with a heating resistor having a built-in thermal switch of a total power of about 35W. It is intended to prevent water vapour condensation and provide for the proper ambient for the proper function of built-in electric control parts of EA in the case of EA low temperatures.

Controller

EA of the **MO** with controller type are equipped with an electronic controller intended for controlling EA by means of input standardized signals.

Reversing contactors

According to specification, EA can involve also reversing contactors for switching on and reversing a three-phases EA electric motor.

Electrical connections

Electrical connections is to be realised according to the specification indicated on terminal or by means of connector.

2.2 Technical data

Basic technical data of EA are presented in table Nr.1

Table no. 1

Type/ type number	Control speed ±10[%] [min ⁻¹]	Number of revolutions 8)	Switching - off torque ⁵⁾⁶⁾ ±10 [%] [Nm]	Weight [kg]	Electric motor				
					Supply voltage		Nominal		
						[V] ±10%	power [W]	speed [1/min]	current ⁷⁾ [A]
1	2	3	6	7	8	9	10	11	12
MO(R) 3.3 t.n. 103	25	1,75- 206	120 - 300	cca 38 ± 5%	Three - phase	Y / Δ; 380 / 220; 50 Hz Y / Δ; 400 / 230; 50 Hz	940	2735	2,3
	45 ⁹⁾						1450	2820	3,3
MO 3.4 Type number 105	10	1,3 - 285	100 – 200	cca 42 ± 5%			250	850	0,78
			200 – 300				370 – 370	1370	1,03
			250 – 350						
	100 – 180								
	16		150 – 200				550	910	1,6
			200 – 250						
			250 – 350						
	25		100 – 150				370	1370	1,03
			150 – 200						
			200 – 250						
			250 – 350						
	40 ⁹⁾		100 – 170				550	1395	1,86
			150 – 200						
			200 – 300						
			200 – 300						
	63 ⁹⁾		100 – 150				750	2820	3,3
200 - 300									
100 - 150									
200 - 300									
80 ⁹⁾	100 - 200	1450	2855	1,73					
	200 - 250								
	1450				2820	3,3			
	1100				2845	2,4			
MO 3.5 type number 095	25	1,5 - 185	80 – 140	cca 49 ± 5%	Three - phase	Y / Δ; 380 / 220; 50 Hz Y / Δ; 400 / 230; 50 Hz	1450	2820	3,3
			140 – 320				940	2735	2,30
			300 – 450				1450	2820	3,3
	400 – 550		940				2735	2,3	
	80 – 140								
	140 – 320								
	32		300 – 450				1450	2820	3,3
			400 – 530						
			80 – 140						
			140 - 260						
	40 ⁹⁾		260 – 320				940	2735	2,3
			300 – 380						
1450		2820	3,3						
1450		2820	3,3						

Next page>>>>>>

Table Nr. 1

Type/ type number	Operating speed $\pm 10\%$	Number of revolutions ⁸⁾	Switching - off torque ⁵⁾¹⁰⁾ $\pm 10\%$	Weight	Electric motor ¹⁾				
					Supply voltage		Nominal		
							power	speed	current ⁷⁾
	[min ⁻¹]	revolutions	[Nm]	[kg]	[V] $\pm 10\%$	[W]	[1/min]	[A]	
1	2	3	6	7	8	9	10	11	12
MO 3 type number 52 000	10	1 ÷ 380	16 – 40	cca 26,5 – 34,5	Three - phase	3x400, (3x380)	180	900	0,62
			32 – 90						
			80 – 130						
			100 – 150						
	16		16 – 40				120	1380	0,42
			32 – 90						
			80 – 130						
			100 – 150						
	25		16 – 40				250	1350	0,76
			32 – 90						
			80 – 130						
			100 – 150						
	40 ⁹⁾		16 – 40				180	1380	0,56
			32 – 90						
			80 – 130						
			100 – 150						
63 ⁹⁾	16 – 40	250	1350	0,76					
	32 – 90								
	80 – 130								
	100 – 150								
			16 – 40			180	1380	0,56	
			32 – 90			250	1350	0,76	
			80 – 130			370	1370	1,03	
			100 – 150			370	1370	1,03	
			16 – 40			250	1380	0,76	
			32 – 90			370	1380	1,03	
			16 – 40			370	1380	1,03	
			32 – 63			370	1380	1,03	

Remarks:

- ¹⁾ Switching elements for different type of load (also for EA) defines standard EN/IEC 60 947-4-1.
- ⁵⁾ State the switching - off torque in your order by words. If not stated it is adjusted to the maximum rate of the corresponding range.
- Starting torque is min. 1, 3 multiple of maximum switching-off torque of selected range.
- ⁶⁾ Max. load torque is equal to:
- 0, 6 multiple of max. switching-off torque for operating mode S2-10min, respectively S4-25%, 6-90 cycles / hr.
 - 0, 4 –multiple of max. switching-off torque for operating mode S4-25%, 90-1200 cycles / hr.
- ⁷⁾ Applies to voltage 3x400V AC.
- ⁸⁾ State individual number of working revolutions in the order. Provided customer doesn't specify otherwise, EA will be set to 6° by producer.
- ⁹⁾ Valid for the version without any controller.
- ¹⁰⁾ Max. load torque is equal to:
- 0, 8 multiple of max. switching-off torque for operating mode S2-10min, respectively S4-25%, 6-90 cycles / hr.
 - 0, 6 –multiple of max. switching-off torque for operating mode S4-25%, 90-1200 cycles / hr.

Other technical data:

The cover of electric actuator.....**IP 55** (IP67 - after agreement with manufacturer)(EN/IEC 60 529)

Mechanical ruggedness:

Sinusoidal vibrations with frequency with in 10 up to 150 Hz with shift amplitude 0, 15 mm for $f < f_p$
with acceleration amplitude 19, 6 m/s² for $f > f_p$
 (transient frequency f_p must be within range 57 up to 62 Hz)

Sesistibility against drops300 drops with acceleration 5 m.s⁻²

Self-locking:guaranteed within range from 0 % up to 100 % switching - of torque

Switches: DB 6 (Cherry) switches

Supply voltage 250 V (AC), 50/60 Hz, 2 A; resp.: 250 V (DC), 0,1 A

Manual control:

By hand wheel; after releasing of locking screw even during operation of the electric motor. By rotation of hand wheel clockwise is electric actuator output shaft shifted towards „close“.

Electric control:

- standard for **EA MO** - on the supply voltage level
- standard for **EA MO** with built-in controller - by feeding of unified signal
- for the EA version **MO** with external controller – by feeding of unified signal.

Output part backlash: < 5 ° at the load by 5% value switching of torque

Heating element (E1)

Heating resistor – supply voltage: max. 250 V AC;
Heating output: about 35 W/55°C

Thermo-switch of heating element (F2)

Supply voltage: 230 V AC, 5 A
Temperature of conduction: +20°C ± 3 °C
Temperature of disconnection: +30°C ± 4 °C

Position switch adjustment

End position switches are preset to a specified revolutions number with an accuracy of ± 90° .
Additional position switches are preset to close immediately before appropriate end position switches.

Adjustment of torque switches

Switching of torque, unless other adjustment is specified, is set up to maximum switching of torque of selected range with tolerance ±10 %, for repeated torque switching-off.

Position transmitter

Resistive – potentiometer:

Resistance (single **B1**): 100 Ω, 2000 Ω
Resistance (double **B2**): 2x100 Ω, 2x2000 Ω
Operating life of transmitter 1.10⁶ cycles
Load capacity: 0.5 W up to 40°C (max. 0 W/125°C)
Maximum current of sliding contact max. 35 mA
Maximum supply voltage: $\sqrt{P \times R}$ V DC/AC
Potentiometer linearity error: ±2.5 [%]¹⁾
Potentiometer hysteresis: max. 5 [%]¹⁾
For MO: "O" (open) ≥ 93%, "Z" (closed) ≤ 5%
For MO with controller: "O" (open) ≥ 85 % and ≤ 95%, "Z" (closed) ≥ 3 % and ≤ 7%

Electronic positional transmitter (EPV) - converter R/I (B3)

a) 2-wire version - without built-in power supply, or with built-in power supply

Current signal 4 ÷ 20 mA (DC)
Power supply voltage (at version without built-in power supply) 15 ÷ 30 V DC
Power supply voltage (at version with built-in power supply) 24 V DC ±1,5%
Load resistance max. $R_L = (U_n - 9V) / 0,02A$ [Ω]
(U_n - power supply voltage [V])
Load resistance (at version with build-in power supply) max. $R_L = 750 \Omega$
Output signal values at limit positions: "O" 20 mA (clamps 81,82)
..... "Z" 4 mA (clamps 81,82)
Values tolerance of output signal of EPV "Z" +0,2 mA
..... "O" ±0,1 mA

b) 3-wire version - without built-in power supply, or with built-in power supply

Current signal 0 ÷ 20 mA (DC)
Current signal 4 ÷ 20 mA (DC)
Current signal 0 ÷ 5 mA (DC)
Power supply voltage (at version without built-in power supply) 24 V DC ±1,5%
Load resistance max. 3 kΩ
Temperature dependency max. 0,020 mA / 10 K
Output signal values at limit positions: "O" 20 mA or 5 mA (clamps 81,82)
..... "Z" 0 mA or 4 mA (clamps 81,82)
Values tolerance of output signal of EPV and capacitive transmitter "Z" +0,2 mA
..... "O" ±0,1 mA
EPV linearity error: ±2.5 %¹⁾
EPV hysteresis: max. 5 %¹⁾

Capacitive (B3): non-contact, life 10⁸ cycles

2-wire connection with power supply or without power supply

The current signal **4 ÷ 20 mA** (DC) is acquired from the capacitive transmitter supplied from the internal or an external voltage supply source. The electronics of the transmitter is protected against eventual wrong polarity and current overloading. The entire transmitter is galvanic insulated so several transmitters can be connected to one external voltage source.

Power supply voltage (with power supply)	24 V DC
Power supply voltage (without power supply)	18 to 28 V DC
Ripple voltage	max. 5%
Max power input	0,6 W
Load resistance	0 to 500 Ω
Load resistance can be single side grounded.	
Influence of resistance on output current	0,02%/100 Ω
Influence of voltage on output current	0,02%/1V
Temperature dependency	0.5% / 10 $^{\circ}$ C
Output signal values at limit positions:	

“O“ 20 mA (clamps 81; 82)

“Z“ 4 mA (clamps 81; 82)

Values tolerance of output signal of capacitive transmitter

“Z“ +0,2 mA

“O“ \pm 0,1 mA

Capacitive transmitter linearity error	\pm 1,2[%] ¹⁾
Capacitive transmitter hysteresis	max. 5 [%] ¹⁾

1) of the transmitter's nominal value related to output values with max. revolutions setting for the given stroke degree according to table 3

Electronic position controller (N) „REGADA“ (Valid for the EA MO version with controller only)

Controller software equipment:

A) Function and parameters

programmable **functions**:

- with functional buttons SW1, SW2 and LED diodes D3, D4 directly placed on controller
- with computer or terminal equipped with corresponding programme, using RS 232 interface.

programmable **parameters**:

- control signal
- response to SYS-TEST signal
- mirroring (ascending/descending characteristics)
- insensitiveness
- EA limit positions (only with computer and ZP2 programme)
- way of regulation

B) Operation states of controller

Error message from error memory: (using LED diodes and RS 232 and personal computer)

- control signal missing or faulty
- input value of current control signal under 3.5 mA
- existence of SYS-TEST signal
- activity of switches
- failure of feedback position transmitter

Statistic data: (using RS 232 and personal computer)

- number of controller operation hours
- frequency of relay switching in direction "opening"
- frequency of relay switching in direction "closing"

Supply voltage: terminal 61 (L1) -1(N) - 230 V AC \pm 10%

Frequency: 50/60 Hz \pm 2%

Input control signals - analogue: 0 - 20 mA

..... 4 - 20 mA

..... 0 - 10 V

Input resistance for signal 0/4 - 20 mA.....250 Ω

Input resistance for signal 0/2 - 10 V 50k Ω

(Actuator opens at rising of control signal.)

Controller linearity: 0.5 %

Controller insensitiveness: 1 - 10% (adjustable)

Feedback (position transmitter): resistive 100 up to 10,000 Ω

..... current 4 up to 20 mA
Power outputs: 2x relay 5A/250V AC
Digital outputs:4x LED (supply, error, adjustment, "opening", "closing" - with two-colour LED)
Error status: control switch 24 V, 2W - POR
Reaction at error situation: transmitter error - error message LED
Control signal missing: error message LED
SYS mode: error message LED
Adjusters: communication connector
 2x calibrating and adjusting button

2.2.1 Mechanical connection

- By flange F10, F14 resp. F16 (ISO 5210, DIN 3338)
- By flange φ220 resp. φ135 (GOST R 55510)

Main and connecting dimensions are presented in **dimensional drawings**.

2.2.2 Electric connection

a) Electric actuator

to terminal box type (X): - max. 32 terminal connectors , crosscut of connecting wire max. 2,5 mm² for version without contactors, resp. max. 24 terminal connectors, crosscut of connecting wire max. 2,5 mm² and max. 6 terminal , crosscut of connecting wire max. 1,5 mm² for version with contactor
 - 2 cable bushings from control box – M25x1,5 cable diameter 12,5 to 19 mm

to connector (XC): - (max. 32 poles - the crosscut of connecting wire 0, 5 mm²):
 - 2x cable bushings-M20x1,5 and M25x1,5 cable diameter from 8 -14,5 mm and 12,5 - 19 mm

b) 3~ electric-motor

in a terminal board make: through bushing M25 to the motor terminal board
in connector make:..... to common connector (XC)

- **with protection terminal:**
 external and internal, mutually connected and marked with protection earthling mark.

Electric connection: according to wiring diagrams.

3. Installation and dismantling of actuator



Abide by safety measures!

Notes:

Repeatedly verify whether placing of EA corresponds to part "Operating conditions". If actual conditions differ from recommended, it is necessary to consult it with manufacturer.

Before starting of mounting the EA onto the valve:

- Check again whether the EA was not damaged during storing.
- Check whether the adjusted operating speed angle and connecting dimensions of the actuator (see the nameplate) are in compliance with the valve parameters.
- In case of inconsonance, perform adjusting according to the part Adjustment.

3.1 Installation

The actuator is set up by the manufacturer to the parameters according to label tag, with connecting dimensions according to relevant dimensional drawing and is set to mid - position.

Put on the hand wheel before assembly.

3.1.1 Mechanical connection to the armature

In case that required shape of mechanical connection is designed by A-shape adapter (with flange F16, F14 or F10), resp. C-shape adapter (with flange F14) at first is necessary to fix this adapter to connecting flange of EA by the screws.

Mechanical connection – shape of connecting element B, C, D, E (eventually B3) and gear clutch :

- Bearing surfaces of EA connecting flange must be carefully de-greased.
- Slightly grease the shaft of armature/gearbox by acid-free grease;
- Shift EA to its terminal position „CLOSED“; shift armature into identical terminal position.
- Put EA on armature, so as output shaft reliably fits into clutch of armature.

Warning!

Do not use force when you put EA on armature, otherwise the gear can be damaged!

- Should there is the necessity to synchronize the openings in the EA flange and armature, turn the EA by hand wheel;
- Verify, whether connecting flange fits tightly to the armature / gearbox.
- Attach the flange by four bolts (with mechanical hardness min. 8G), which steadily tighten crosswise.
- At the end of mechanical connection perform **the check of proper connection with the armature**, by turning hand wheel in the „open“ direction.

Mechanical connection – rising spindle (for shape A, C resp. B3):

- If the rising spindle of armature is in terminal position „open“ longer than dimension of mounting flange up to the control box cover, disassembly cover of output shaft (Fig.1) on control box and replace it by covering pipe (not part of delivery) after assembly of electric actuator on armature.
- Seating surfaces of EA connecting flange and armature carefully de-grease.
- Slightly grease the output shaft of armature.
- Shift EA to terminal position „CLOSED“; shift armature into identical terminal position.
- Slide electric actuator by output shaft / nut on the spindle / nut of armature and turn by hand wheel counterclockwise until connecting flange of electric actuator fits to connecting flange of armature. Further procedure is identical to previous part of mechanical connection for shapes B, C, D.
- At the end of mechanical connection perform the check of proper connection of EA with the armature by turning the hand control wheel wheel in the „open“ direction.

Note:

It is also possible to fix the EA on the wall construction using the three feeders located at the box external wall, opposite to the hand wheel.

3.1.2 Electric connection to the network, respectively control system

Consequently perform electric connection to the network, respectively to joining system.



1. Adhere to instructions stated in chapter 1.2 Safety instructions – Requirements for professional....
2. While laying electrical line abide by the instructions for heavy current installations. Power supply cables must be of the type approved. Minimum thermal resistance of power supply cables and wires must be +90°C.
3. Line wires to terminal boards, respectively to connector lead by screw cable bushings.
4. Before putting the electric actuator into operation is necessary to connect inner and outer grounding terminal.
5. Leading-in cables must be attached to firm construction maximum 150 mm from bushings!
6. To prevent moisture from entering the actuator around the connecting cables, the cables must be sealed with silicone material at the point of penetration through device shell.

Connecting to terminal board

Before electric connection remove the cover of electric actuator control box and check whether the type of electric current, supply voltage and frequency comply with data on electric motor type label.

Electrical connections:

- Electrical connections are to be realised according to an electric plan attached in the EA casing.
- Electrical connections is to be done through two cable bushings to the control box and 1 cable bushing to electric motor.
- If necessary, make EA adjustment, place cover and fasten it by screws uniformly in diagonal way. Tighten cable bushings firmly, only then the protection is assured.

Electric connection to connector

- Check, whether the type of electric current, supply voltage and frequency comply with data on electric motor type label.
- Release bodies of the connectors.
- Electric connection performed through two bushings.
- Strip the ends of wires.
- Attach relevant connector tubes to the wire ends by means of pliers.
- Slide the tubes into relevant contacts of connector according to connection drawings.
- Fasten and tighten connectors.
- Firmly tighten cable bushings to secure coverage.

Remarks:

1. Stuffing bushings are delivered with EA, which in case of tight mounting on supply line secure coverage up to IP 68. For required coverage is necessary to use ringlets according to actual cable diameter and required thermal resistibility.
2. During attachment of a cable is necessary to watch acceptable bending radius to prevent damage, respectively not acceptable deformation of sealing element of cable bushing. Supply cables must be attached to firm construction maximum 150 mm from bushings.
3. For connection of remote transmitters is recommended to use shielded wires.
4. Sealing surfaces of control part cover must be cleaned before repeated fastening.
5. EA reversal is secured, if time interval between switching OFF and ON of supply voltage for reverse direction of output part motion is minimum 50 ms.
6. Delay after turn-off, i.e. time from reaction of the switches until the motor is without voltage, can be max. 20 ms.



Adhere to instructions of armature manufacturers, whether turn-off in terminal positions must be executed via position, or force switches!

The check of el. motor connection and control drawing. Set up the electric actuator by hand wheel to mid position. Check proper connection by pressing the pushbutton "close" (on the box of manual control, respectively on the panel of testing pushbutton box) and output shaft must turn clockwise from the view from the top view (into control box) on output shaft. If it is not so, change the sequence of electric power network phases.

Check of torque switches (Fig.5). When the actuator moves towards "close" and at torque switches connection to "torque switching-off" should be contacts of switch S2 switched over by pressing of disconnecting bell (24)(Fig.5) of relevant switch. If the connection is properly performed, the actuator must stop. When the torque switches are connected for "signalization" only, signalization on control box panel will be activated.

Analogous repeat test towards "open" by switching over of switch S1 contacts. If any of function is not correct, check the connection of switches according to wiring diagram.

Check of position switches (Fig.6,8). When the actuator moves towards "close" switch over contacts of switches S4 resp. S6 by pressing of disconnecting bell of relevant switch. If the connection is properly performed, the actuator must stop when contacts of switch S4 are switched over and light up when contacts of switch S6 are switched over. Analogous repeat test towards "open". By pressing disconnecting bell of switches S3 resp. S5, the actuator must stop resp. signalize. Again, if any of the function is not correct, connection of switches should be checked according to wiring diagram.



In the **EA MO** with controller **version** with the built-in electronic controller (Fig.13) it is needed to perform **autocalibration** for assuring optimal functioning.

The procedure is as follows

- Preset the EA to a mid-position position (position and torque switches are not hooked)
- Press the button **SW1** for about 2 sec (i.e. till the **D3** diode is got on) to set the controller to the **autocalibration** mode. During this process the controller checks the feedback transmitter and the sense of turning, puts the EA to the positions open and closed, measures inertia mass in the directions "opening" and "closing", and loads the adjusted parameters into the EEPROM memory. In case that during the initialization process an error occurs (e.g. in connection or adjustment) the initialization process will be interrupted and the controller with the **D4** diode reports about the type of the error. Else after finishing the initialization process the controller is put into the **regulation mode**. If needed to change adjusted parameters of the controller follow instructions given in the part "Adjusting of actuator".

3.2 Disassembly



Attention!

Before disassembly is necessary to disconnect electric supply of electric actuator!

Connection and disconnection of connectors must not be performed under the voltage!

Secure by prescribed way protection against connection of EA to the network and thus potential electrical accident!

- Disconnect the EA from mains.
- Disconnect the leads from the EA terminal boards and loosen the cables from bushings. Pull out the connectors in case of the connector version.
- Loosen the fixing screws of the EA flange and disconnect the EA from the valve/gearing.
- While sending the EA to be repaired put it into a package solid enough to avoid damages of the EA during transportation.

4. Adjusting



Attention! See chapter 1.2

If it is necessary to connect the supply voltage to Electric actuator, make sure by following the mentioned procedure that there is no injury caused by the electric current. Otherwise, disconnect the Electric actuator from the electricity network.

Observe safety regulations!

After mechanical connection, electrical connection and checking of connection and function start setting and adjustment of the device. The adjustment can be performed at a mechanically and electrically connected EA. This part describes adjustment of EA to specified parameters in case that any unit of EA is reset. Laying of adjusters of the control board is shown on Fig.3

4.1 The torque unit adjustment (Fig. 4 and 5)

It is only possible to set up the switching – off torque using the torque measuring equipment and only within the particular range with application of rough adjustment (17) and soft adjustment (18), Figure 4, according to the Version Table.

It is only possible to readjust the electric actuator using the segments (17), Fig. 4, within the marked MIN - MAX limit on the torque wrench and within the particular electric actuator torque range.

To change the torque range, the springs need to be replaced in the torque drive, executable in the manufacturing concern or service station from the point of view of mounting seriousness.

Blocking adjustment:

EA operates within a working revolutions range according to Variant table.

Blocking can be set to a number of revolutions given in tables 2a, 2b.

TABLE Nr. 2a				
Torque blocking speed for the version with more than 5 working revolutions for EA (1 pin in driving wheel)				
MO 3	MO 3.3	MO 3.4	MO 3.5	Cams on pinion (25) are revolved by
1,0 – 2,0	-	-	-	90°
3,0 – 4,0	1,0 – 1,25	1,25 – 1,7	0,8 – 1,1	180°
5,0 – 6,0	1,5 – 1,9	2,1– 2,5	1,36 – 1,7	270°
7,0 – 8,0	2,1 – 2,5	3,0 – 3,35	1,9 – 2,18	360°

TABLE Nr. 2b				
Torque blocking speed for the version with less than 5 working revolutions for ES (3 pins in driving wheel)				
MO 3	MO 3.3	MO 3.4	MO 3.5	Cams on pinion (25) are revolved by
0,33 – 0,66	0,099 – 0,2	0,13 – 0,28	0,09 – 0,18	90°
1 – 1,33	0,3 – 0,4	0,42 – 0,56	0,27 – 0,36	180°
1,66 – 2	0,5 – 0,6	0,7 – 0,85	0,45 – 0,55	270°
2,33 – 2,66	0,7 – 0,8	0,97 – 1,12	0,63 – 0,73	360°

The torque unit blocking is set by the producer withing the range marked in bold in the following table. In case the revolutions modification is needed please contact the authorized service center.

4.2 Position switches adjustment (S3(S13),S4(S14) (Fig. 6)

EA is delivered set to a stroke corresponding to 6th according to table 3 or to a stroke required by customer. The stroke referred on the type label of EA corresponds to the maximum stroke with the gear unit set to 11th according to table 3. The procedure for position switches setting, adjustment a new setting is as follows (Fig. 6, 7):

- With variant having resistance transmitter, disengage the transmitter, (Fig.9)
- Having the set screw of the gear unit wheel released, move the adjustable wheel to a required stage of the range (it means to a one corresponding accurately to the particular revolutions, or to the next higher one) according to table 3 and Fig.7. When moving the adjustable wheel, take care to achieve the proper meshing with the gear wheel of the subjected stage, and then tighten the set screw back.
- Move EA to the "open" position electrically or manually. If, with electric move, EA has been switched off by S3 switch (Fig. 6), insert a screwdriver into set screw (29), press it and rotate in the arrow direction until an appropriate cam opens S3 switch. Pull the screwdriver out (see notice 1) and continue in moving EA in the „open“ position.
- In the „open“ position, insert a screwdriver into set screw (29), press it and rotate in the arrow direction until an appropriate cam closes S3 switch. Pull the screwdriver out (see notice 1).
- Move EA to the "close" position electrically or manually. If, with electric move, EA has been switched off by S4 switch (Fig. 6), insert a screwdriver into set screw (28), press it and rotate in the arrow direction until an appropriate cam opens S4 switch. Pull the screwdriver out (see notice 1) and continue in moving EA in the „close“ position.
- In the „close“ position, insert a screwdriver into set screw (28), press it and rotate in the arrow direction until an appropriate cam closes S4 switch. Pull the screwdriver out (see notice 1).
- Having position switches adjusted, You may need (depends on EA accessories) to adjust signaling switches, position transmitter, converter, position indicator and controller.

Notice 1: in the case that the set screw remains pressed notwithstanding the screwdriver is out (it means that disengaged gear wheels don't mesh each other), turn gently the set screw against the arrow direction without pressing it until the set screw releases back to its initial position.

*Notice 2: In the case of EA version with **tandem position switches S13, S14** those switches are adjusted after adjustment of switches S3 and S4, i.e. the switch S3 switches simultaneously with switch S13 and switch S4 switches simultaneously with switch S14.*

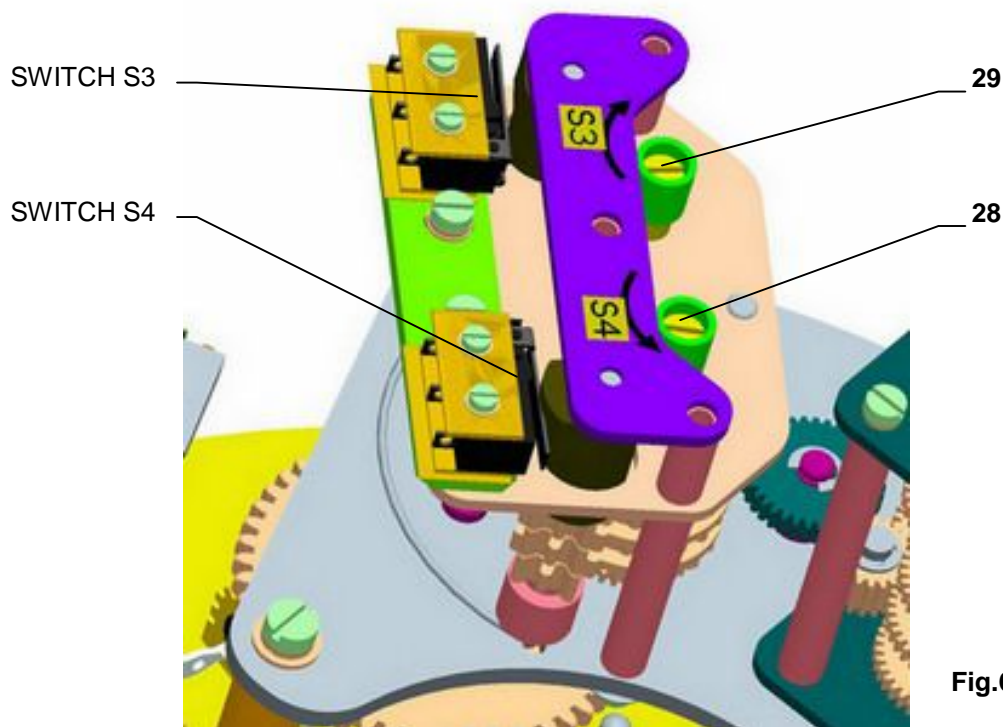
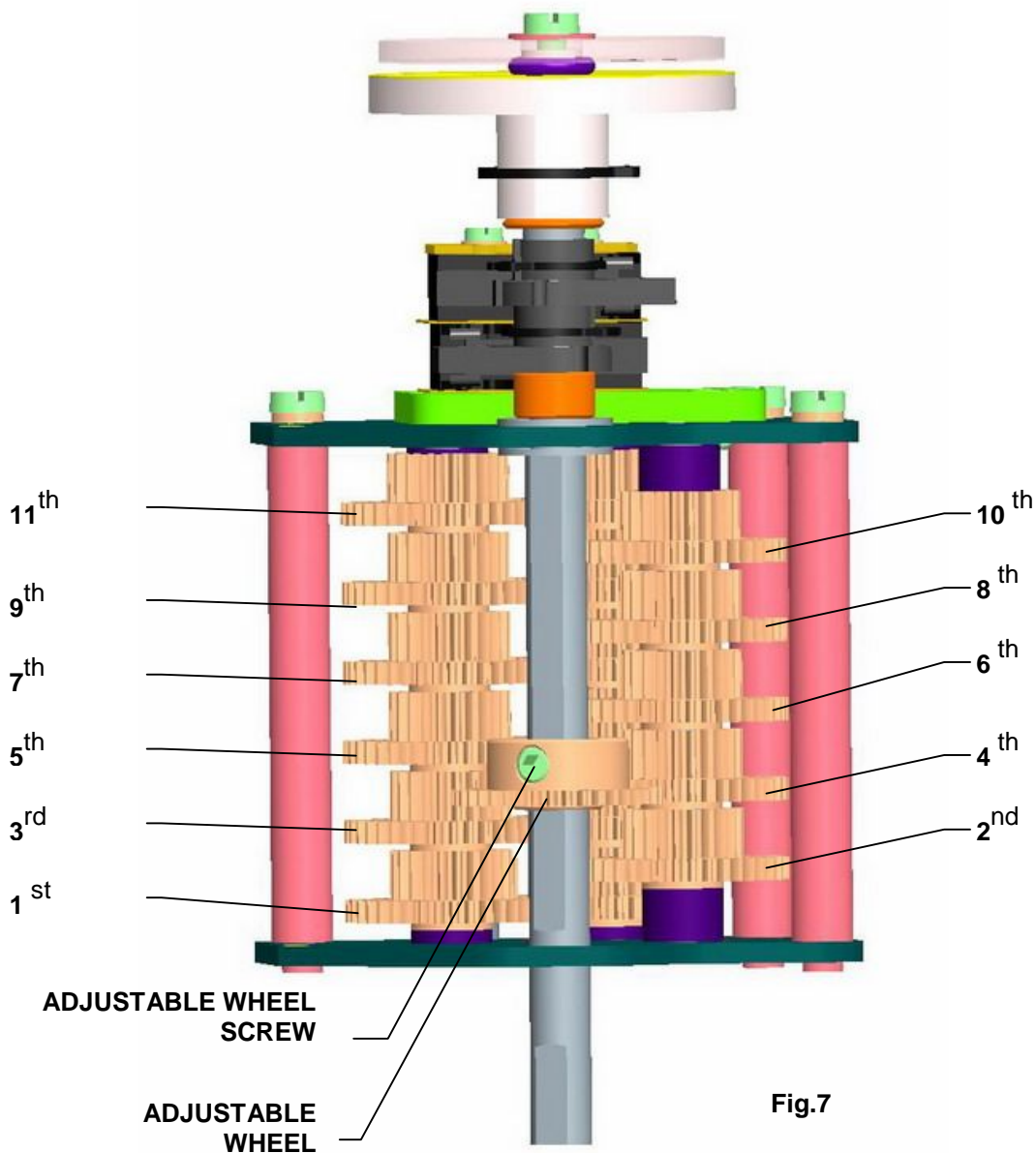

Fig.6

TABLE 3				
STROKE STAGE	MAX. EA WORKING REVOLUTIONS (provided customer doesn't specify otherwise, EA will be set to 6 th by producer)			
	MO 3	MO 3.3	MO 3.4	MO 3.5
1 st	1,75	-	-	-
2 nd	3	-	1,3	-
3 rd	5,7	1,75	2,4	1,5
4 th	10,5	3	4,4	2,8
5 th	19	5,7	8	5
6th	34	10,5	14,5	9,5
7 th	63	19	26	17
8 th	113	34	48	31
9 th	206	63	85	56
10 th	375	113	155	100
11 th	685	206	285	185



4.3 Signaling switches adjustment (S5,S6) (Fig. 8)

The signaling switches of EA are at producer preset to switch on about 10% before end positions provided the customer not specified otherwise. Before proceeding with signaling switches adjustment, S3, S4 end position switches must be adjusted according to the previous chapter if necessary. The procedure of signaling switches adjustment is as follows:

- Check that the adjusting wheel of the signalling gearbox is adjusted to the required level of the stroke scope.
- Bring EA to a position in which You want S5 switch to close when EA is running in the „open" direction.
- Turn cam (31) of S5 switch (27) clockwise until S5 switch closes.
- Bring EA to a position in which You want S6 switch to close when EA is running in the "close" direction.
- Turn cam (30) of S6 switch (26) counterclockwise until S6 switch closes.

Notice: This signaling is capable to signalise from 50 up to 100 %..of the working stroke in both movement directions. With switch reversing function, a signaling capability from 0 up to 100 % is available.



Fig.8

4.4 Position indicator adjustment (Fig.8)

The position of the output member relative to the end positions of EA stroke is indicated by a mechanical position indicator.

- Before starting to adjust the position indicator, S3 and S4 position switches must be adjusted if required.
- The procedure of position indicator adjustment is as follows :
- Bring EA to the „closed" position.
- Turn the position indicator disc (32) to bring a mark identified with a symbol for the „close" direction in coincidence with a mark on the upper cover aperture (If it is difficult to turn the wheel, release the screw using the screwdriver to fix the wheel).
- Bring EA to the „opened" position.
- Turn the upper part of the position indicator disc (32) to bring a mark identified with a symbol for the „open" direction in coincidence with the mark on the upper cover aperture.

4.5 Adjustment of resistant transmitter (Fig.9)

Function of resistance transmitter:

- remote position indicator
- feedback for controller (valid for Electric actuator with controller)
- remote position indicator with converter.

Before the resistant transmitter adjustment the position switches have to be adjusted. Adjustment consists in setting of the resistance in the defined limit position of the EA.

Notes:

1. In case that the EA is not used in the working revolutions range according to chosen degree on the competent stroke according to table 3, the resistance in the limit position "open" is proportionally reduced.
2. In the EA MO with controller 2000 W resistant transmitters are used. In the other cases if the resistant branch is lead to the terminal board the resistance of the transmitters is according to the customer's specification. With EA of 2- wire converter a transmitter of 100 W resistance is used .

To adjust the transmitter follow these steps:

- Loosen the fixing screws (90) of the transmitter holder and push the transmitter out of mesh.
- Connect the measuring instrument for measuring the resistance to terminals 71 and 73 on the Electric actuator local control terminal box, or to terminals 7 and 10 on the Electric actuator local control controller with the controller with the disconnected supply voltage to Electric actuator and with the disconnected input signal into the controller (terminals 86-88).
- Put the actuator to the position "closed" (with the hand wheel, or with the local electric position control until the corresponding position switch S2 or S4 switches).
- Rotate the transmitter (91) shaft until resistance of $\leq 5\%$ of the nominal transmitter resistance can be read on the meter in case of EA **MO**, and 3 up to 7% of the nominal transmitter resistance in case of EA **MO** with controller, i.e. with the resistant transmitter with the converter PTK1.
- In the position put the transmitter to mesh with the drive wheel and fix the fixing screws on the transmitter holder.
- If when in the open position, the value of the resistance of the transmitter is greater than permitted, then the working stroke must be reduced.

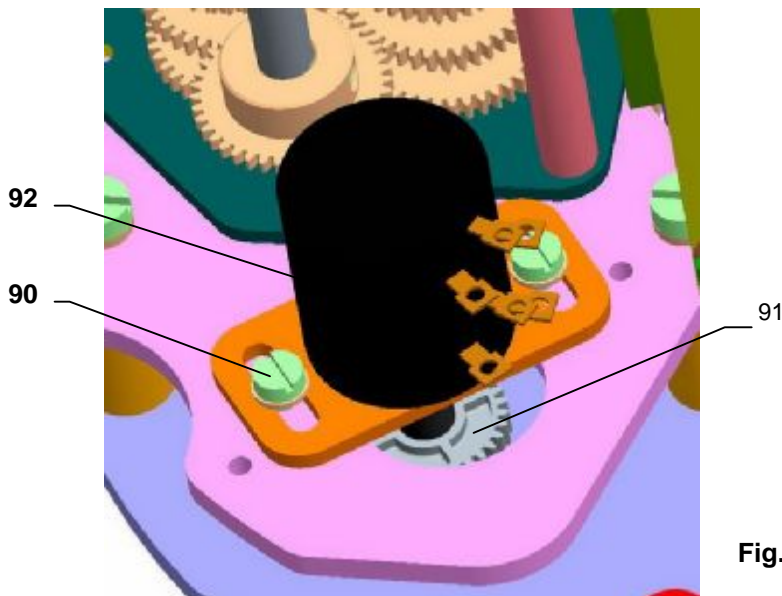

Fig.9

4.6 Adjustment of the Electronic Position Transmitter (EPV) - the Resistive Transmitter (Potentiometer) with the Converter PTK 1

4.6.1 EPV – the 2-wire version (Fig. 10)

The position transmitter with the converter PTK1 is in the plant adjusted to have the output current signal on the terminals 81-82 as follows:

- in the position "open" 20 mA
- in the position "closed" 4 mA

Adjustment of the EPV in electric actuators MO

If the transmitter requires a new adjustment follow these steps:

- Put the actuator to the position "closed" and switch the power supply off.
- Adjust the resistive transmitter according to the previous chapter. The resistance is to be metered on the terminals X-Y (Fig. 10). The used transmitter resistance is 100 Ω.
- Switch the converter's power supply on.
- Turn the adjusting trimmer ZERO (Fig. 10) to adjust the output current signal rate measured on the terminals 81-82 to 4mA.
- Set the actuator to the position "open".
- Turn the adjusting trimmer GAIN (Fig. 10) to adjust the output current signal rate measured on the terminals 81-82 to 20mA.
- Check the output signal of the converter in the both limit positions, and repeat the procedure if needed.

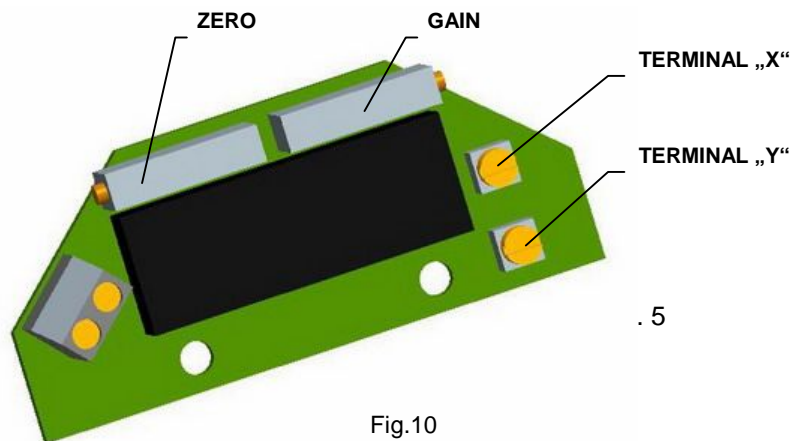

Fig.10

Note:

The output signal of 4-20mA can be adjusted at the range from 75 up to 100% of the rated stroke according to table Nr.3 . At values less than 75% the value 20mA is reduced proportionally.

4.6.2 EPV – 3-wire version (Fig. 11)

The resistive transmitter with the converter is in the plant adjusted to have the output current signal metered on the terminals 81-82 as follows:

- in the position "open" 20 mA or 5 mA
- in the position "closed" 0 mA or 4 mA

according to the specified version of the converter.

If the transmitter requires a new adjustment follow these steps:

- Put the actuator to the position "closed" and switch the power supply off.
- Adjust the resistive transmitter according to the previous chapter. The resistance is to be metered on the terminals X-Y (Fig. 11). The used transmitter resistance is 2000 W or 100 Ω.
- Switch the converter's power supply on.
- Turn the adjusting trimmer ZERO (Fig. 11) to adjust the output current signal rate measured on the terminals 81-82 to 0 mA or 4mA.
- Set the actuator to the position "open".
- Turn the adjusting trimmer GAIN (Fig. 11) to adjust the output current signal rate measured on the terminals 81-82 to 20mA or 5 mA.
- Check the output signal of the converter in the both limit positions, and repeat the procedure if needed.

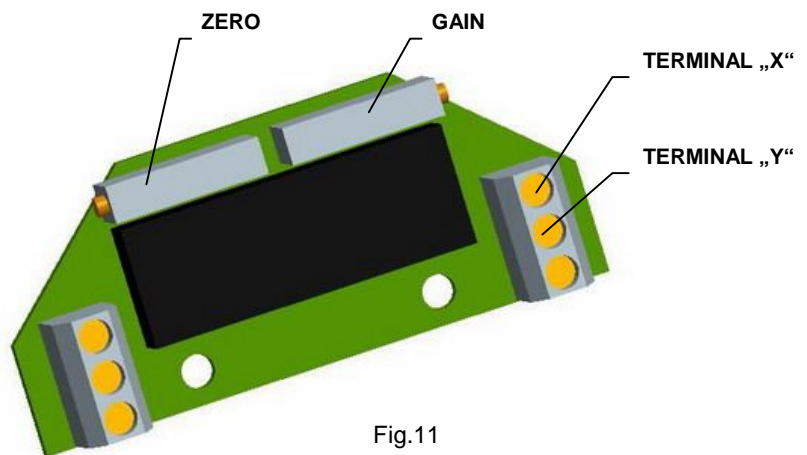

Fig.11

Note:

The output signal of (0-20mA, 4-20mA or 0-5mA - according to the specification) can be adjusted at the range from 85 up to 100% of the rated stroke according to table Nr.3. At values less than 85% the value of the output signal is reduced proportionally.

4.7 Adjustment of Capacitive Transmitter CPT1/A (Fig.12)

The chapter describes adjustment of the capacitive transmitter to the specified parameters (standard values of output signals) in case they are reset. The capacitive transmitter (95) serves as a position transmitter of electric actuators with unified output signal of 4÷20 mA in electric actuators **MO**, or as a feedback of a position controller, or if required it functions also as a remote position transmitter of electric actuators with unified output signal of 4÷20 mA in electric actuators **MO with controller**.

Before adjusting the transmitter, terminal position switches S3 and S4 must be adjusted.

Note1: With the version with controller ; at using the output signal, this signal isn't galvanic insulated from the input signal !

Note2:

In case that reversed output signals are needed (in the position "OPEN" minimum output signal) contact personnel of service centres.

The capacitive transmitter CPT1/A is adjusted by the producer to the fixed Operating angle according to the order and wired according to the wiring diagrams placed into the cover. Check the power supply of the user after connecting to terminal of the terminal board before the transmitter is electrically checked. Adjustment of the capacitive transmitter can be performed when the position switches are adjusted. The adjustment is performed with the power supply of 230 V/50 Hz and ambient temperature of $20 \pm 5^\circ\text{C}$.

The following versions of electric actuators with built capacitive transmitters can be specified:

- A) The version without any power supply** (2-wire version) for EA **MO**
- B) The version with a power supply** (2-wire version) for EA **MO**
- C) The version CPT as a feedback to the position controller** for EA **MO with controller**

A.) Adjustment of the Capacitive Transmitter without any Power Supply

Before connecting check external power supply. The measured voltage should be in range from 18 up to 28 V DC.



*The voltage of the power supply **must not be in any case higher than 30 V DC**. The transmitter can be irreversibly damaged!*

While checking or adjusting the output signal of 4÷20 mA follow these steps:

- Connect a mA meter of precision class 0,5 and loading resistance lower than 500Ω serially with the transmitter (pole "-"; terminal 82).
Put the actuator to the position "CLOSED", the signal value should decrease. In the case that the value of the signal increases, release the fixation screws (96) and turn the transmitter until the value starts to decrease.
- Check the signal value for the position "CLOSED" (4 mA).
- Tune the signal with loosening the fixing screws (96) and turning the trimmer (95) until the required value of 4 mA is reached. Tighten the fixing screws.
- Put the actuator to the position "OPEN", the signal value should raise.
- Check the signal value for the position "OPEN" (20 mA).
- Tune the signal with turning the trimmer (97) until the required value of 20 mA is reached.
- Check the signal value for the position "CLOSED" and then for the position "OPEN".
- Repeat the procedure until the change from 4 to 20 mA is reached with deviation less then 0,5 %.
- Disconnect the meter and lock the screws with a varnish.

B.) Adjustment of the Capacitive Transmitter with the Power Supply

While checking or adjusting the output signal of 4÷20 mA follow these steps:

- Check the power supply: 230 V AC $\pm 10\%$ on the terminals 1,61.
- Connect a mA meter of precision class 0,5 and loading resistance lower than 500Ω on the terminals 81, 82.
- Follow the procedure described in the previous chapter A.

C.) Adjustment of the Capacitive Transmitter Served as a Feedback of the Position Controller (EA MO with controller)

While checking or adjusting the output signal of 4-20 mA follow these steps:

- Disconnect the circuit on the terminals 81 and 82 removing the jumper.
- Connect power supply to the terminals 1 and 61.
- Disconnect the control signal from the terminals 86/87 and 88.
- Put the actuator to the direction "OPEN" or "CLOSE" with the handwheel or by connecting power supply to the relevant terminals for the direction "OPEN", or for the direction "CLOSE".
- Connect a mA meter of precision class 0,5 (e.g. digital) and loading resistance lower than $500\ \Omega$ on the terminals 81,82.
- Follow the procedure for the version without any power supply described in the previous chapter A.
- Having the transmitter adjusted put the jumper again on the terminals 81 and 82 in case that the output signal wont be used (the circuit through the terminals 81 and 82 should be closed).
- Connect the control signal to the terminals 86/87 and 88.



The user has to arrange grounding of the 2-wire circuit of the capacitive transmitter to the electrical ground of a joined controller, computer, etc. The grounding should be performed only in one place in any part of the circuit outside the electric actuator!

With the version with regulator when the feedback from the CPT transmitter is used; at using the input signal, this signal isn't galvanic insulated from the output signal !

Note:

The trimmer (97)(Fig. 12)) can be used to adjust the output signal of the capacitive transmitter to any value of operating revolutions in range from ca 50% up to 100% of the max. value of the operating revolutions on the competent degree according to table 3.

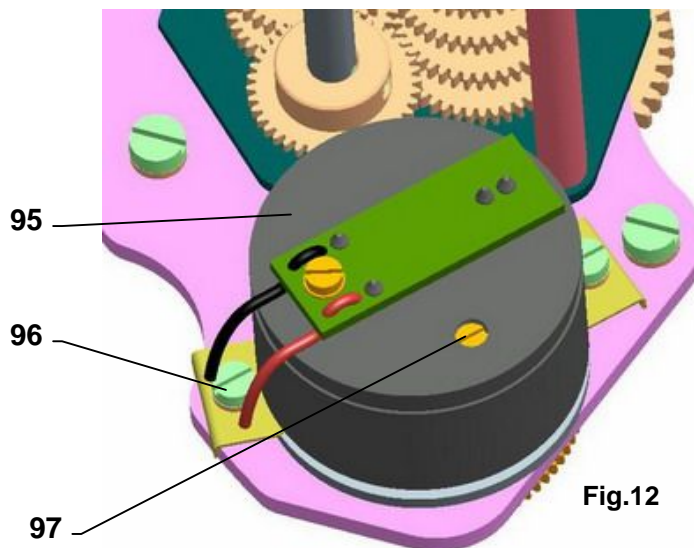

Fig.12

4.8 Adjustment of position controller (Fig. 13)

The built-in position controller REGADA is a user-friendly control system to control actuators with an analogue signal. The controller takes advantages of high-power RISC processor MICROCHIP to perform all functions. It provides also continuous automotive diagnostics of the system, error messages as well as number of relay switching and number of controller's operation hours. Placing an analogue signal onto the input terminals of the terminal board 86 (GND, -) and 88 (+) causes that the EA output is reset.

Required parameters and functions can be programmed using function buttons SW1 - SW2 and LED diodes D3 - D4 placed directly on the controller, see **Table 4**.

4.8.1 Setting of controller

The controller's microprocessor unit is in the production plant programmed to parameters given in **Table 4** (Note 2).

Setting of the controller is performed using buttons and LED diodes.

Adjust the position and torque switches and the position transmitter before adjustment of the controller.

In addition, it is necessary to monitor the correct running of the electric motor concerning the sequence number of phases, otherwise it may happen that during automatic calibration, the engine will run in the opposite direction and the controller will not detect this as an error.

Laying of adjusters and signaling elements on the board of the REGADA controller is shown on **Fig. 13**:

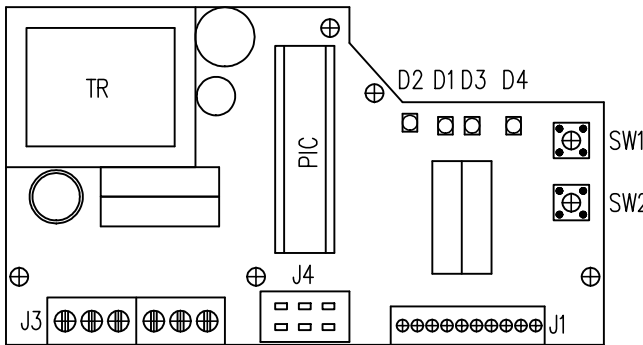

Fig.13

SW1 button	starts an initialization routine and allows listing in the adjust menus
SW2 button	setting of parameters in the chosen menu
D1 diode	power on indication
D2 diode	motion to the direction "opening" indication (green) - "closing" (red) indication
D3 diode	(yellow light) number of blinking codes indicates chosen adjust menu
D4 diode	(red light) number of blinking codes indicates adjusted parameter of the controller from the chosen menu

Table 4:

D3 (yellow) diode number of blinking	Adjust menu	D4 (red) diode number of blinking	Adjusted parameter
1 blink	control signal	1 blink	0-20mA
		2 blinks	4-20 mA (*) (**)
		3 blinks	0-10V DC
2 blinks	response for signal SYS-TEST	1 blink	EA opens receiving signal SYS
		2 blinks	EA closes receiving signal SYS
		3 blinks	EA stops receiving signal SYS (*)
3 blinks	mirroring (ascending/descending characteristics)	1 blink	EA CLOSING at increasing of control signal
		2 blinks	EA OPENING at increasing of control signal (*)
4 blinks	insensitiveness of controller	1 to 10 blinks	insensitiveness of controller of 1-10% (3% set by the producer) (*)
5 blinks	way of regulation	1 blink	narrow torque
		2 blinks	narrow position (*)
		3 blinks	wide torque
		4 blinks	wide position

Notes:

1. The controller at autocalibration automatically sets the feedback type - resistant/current
2. (*) Parameters set in the production plant, if customer has not stated else.
3. (**) Input signal
4 mA - position "closed"
20 mA - position "open"

Standard setting of controller (programmed RESET of controller) –

In the case of problems with setting the parameters, proceed as follows:

- disconnect the supply voltage
- at the same time, press buttons SW1 and SW2
- switch on the supply voltage
 - keep the buttons pressed down until the yellow LED diode starts to flash which indicates that the basic setting is complete.

Controller setting procedure:

The initialization routine starts at the switched-on controller, zero system deviation and short pressing of the **SW1** button for ca 2 sec (i.e. until the diode **D3** got on). Loosing the button menu control signal starts, what is shown with 1 blink on the **D3** diode as well as one of the default parameters (usually control signal of 4-20mA) what is shown with 1 blink on the **D4** diode. Then the required parameters of the controller can be changed according to Table 4:

- press shortly the **SW1** button to list the menu shown with the blinking number on the **D3** diode.
- press shortly the **SW2** button to set parameters shown with the blinking number on the **D4** diode.

After changing of the parameters according to user's wishes, put the controller to **autocalibration** with pressing the **SW1** button for ca 2 sec (i.e. until the diode **D3** got on) , what is shown with 6 blink on the yellow LED **D3** diode.

During this process the controller performs the feedback transmitter and turning sense checking, sets actuator to the positions "open" and "closed", measures inertia mass in the directions "opening" and "closing", and loads the adjusted parameters into the EEPROM memory. In case that during the initialization process an error occurs (e.g. in connection or adjustment) the initialization process will be interrupted and the controller with the **D4** diode reports about the type of the error. Else after finishing the initialization process the controller is put into the regulation mode.

Error messages of the controller with D4 diode at initialization

- 4 blinks.....improper connection of the torque switches
- 5 blinks.....improper connection of the feedback transmitter
- 8 blinks.....bad sense of actuator's turning direction or adverse connection of the feedback transmitter

4.8.2 Watching operation and error states

Watching operation and error states is possible with the EA open.

a) Operation status with the D3 LED diode indicating:

- it is continuously lighting - the controller regulates
- it is continuously not lighting - system deviation in the insensitiveness range - the EA has stopped

b) Error state with the D4 and D3 LED diodes indicating - D4 continuously lighting,

D3 indicates error state with blinking

1 blink (repeated)	indication of the "TEST" mode - the EA is put to the position according to the signal in the "TEST" menu (at connecting the 66 and 86/87 terminals)
2 blinks (repeating after short pause)	missing of control signal - the EA is put to the position according to the signal in the "TEST" menu
4 blinks (repeating after short pause)	torque switches activity indication (the EA switched-off with the torque switches in a mid-position)
5 blinks (repeating after short pause)	failure of the feedback transmitter - the EA is put to the position according to the signal in the "TEST" menu
7 blinks (repeating after short pause)	control signal (current at range 4-20mA less than 4mA (3.5mA).

4.9 Local electric control (Fig.14)

- Additional accessories

In case of necessity (set up, functional check, etc.) but at provided supply is possible to adjust the EA by local electric control. After switch over of mode selector to the mode „LOCAL“ is possible to control the movement of output member in desired direction by direction change over switch. The signal lamps go out with reaching the end position of the appropriate direction.

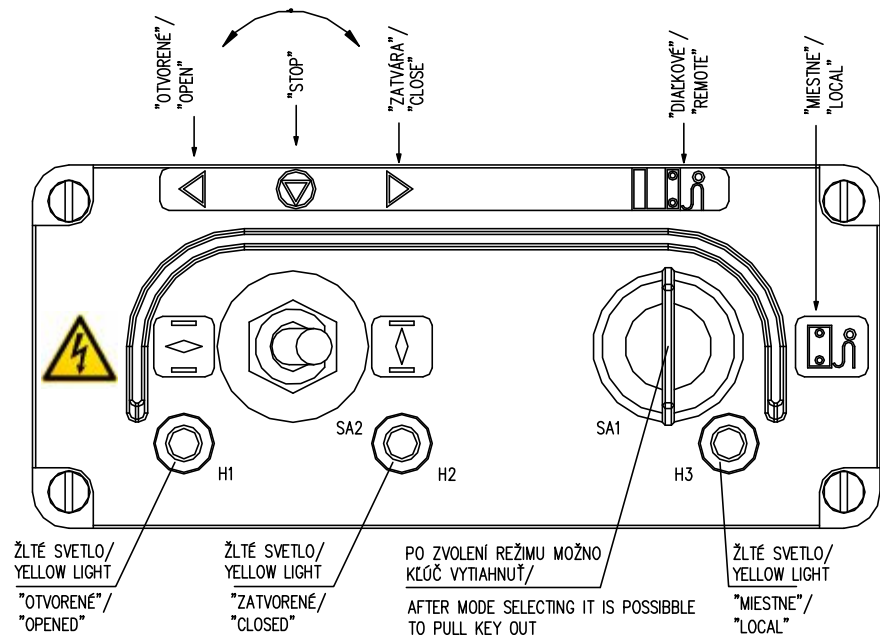

Fig.14

5. Service, maintenance and troubleshooting

5.1 Operation



1. In general it is provided that service of the EA is performed by a qualified worker in accordance with requirement given in Chapter 1!
2. After putting the EA into operation it is needed to verify whether during manipulation any scratch on surface occurred, it is to be removed to prevent actuator against corrosion!

- Electric actuator requires only inconsiderable operation. The assumption for reliable operation is proper putting into operation.
- The operation of these EA comes out of operating conditions and usually consists of information processing for consequential securing of required function.
- EA can be controlled either remotely by electricians, or manually on their assembly position. Manual control is executed via hand wheel.
- The operators must take care for performing of prescribed maintenance and for protection of EA during operation against harmful ambient effects and atmospheric exposure, which exceeds the scope of acceptable effects described in part „Working conditions“.
- Operation beyond the switching – off torque limits is not allowed.
- It is necessary to prevent excessive heating of the surface of EA, exceeding of type label values and excessive vibration of EA.

5.2 Maintenance – scope and regularity

All screws and nuts affecting tightness and protection (IP) must be tightened during the inspection and maintenance. Similarly, once a year should be checked and if necessary tightened mounting screws of the terminal wires and assuring of the slip-on joints with wires.

The interval between two preventive inspections is four years.

In case of damage or after 6 years of the actuator's operation the replacement of cover seals and oil filling seals must be done.

The grease in the supplied actuators is designed for the lifetime of the product.

It is not necessary to change the grease during the operation of the actuator.

In case there is no leakage in the transmission box caused by damaged seal the oil filling is permanent. The change of oil filling shall be done after 6 years of the actuator's operation.

The oil level check must be carried out once in a 3 months interval. The oil level must reach the filling hole. Oil capacity is 1,6 l (1,5 kg).

Lubrication:

- the gearbox: in versions with temperatures –25°C till +55°C - Madit PP-80 (Slovnaft)
 in versions with temperatures –40°C till +40°C - Avia SYNTOGEAR PE 68
- gears of transmission unit and drive mechanism on the control board:
 - in versions with temperatures -25°C till +55°C - grease μ HF 401/0, resp. GLEITMO585
 - in versions with temperatures -40°C till +40°C - ISOFLEX TOPAS AK 50

***Lubrication of the valve stem is independent on maintenance of the EA!***

After every potential flooding of the product check, whether there is no water inside. After eventual water penetration, dry the product before repeated putting into operation and replace damaged sealings, resp. other parts of EA. identically check also tightness of cable bushings and replace them, if they are damaged.

- It is recommended to perform inspection run every 6 months within adjusting working stroke to verify proper function, with reverse adjusting of original position.
- Unless otherwise stated in revision rules, perform inspection of EA once a four years, whereby check tightening of all connecting and grounding bolts, to prevent heat-up.
- 6 months after putting EA into operation and then once a year is recommended to check tightness of fastening bolts between EA and armature (bolts should be tightened by cross method).



- During electric connection and disconnection of EA check sealing rings of bushings – damaged and obsolete sealings replace by original ones!
- Maintain EA clean and take care for removal of impurities and dust. Cleaning should be performed regularly, according to operating options and requirements-

5.3 Troubleshooting

At failure of power supply the EA stops in the position where it was before the failure. If needed the EA can be set only with the manual control (the hand wheel). After restoration of power the EA is prepared for operation.

In case of failure of any element of the EA it can be changed by a new one. Entrust the change to a service centre.

In case of an EA failure, which *cannot* be eliminated directly in operation, follow instructions for under-guaranty and after-guaranty service.

For controller repair a F1,6 A subminiature fuse for DPS should be used, alternatively also F 2A, 250 V e.g. Siba type 164 050.1,6 or MSF 250, and for DB voltage source repair a M160 mA, 250V fuse, e.g. Siba, or MSF 250.

Note:

If the EA requires dismantling follow the chapter "Dismantling".



Taking the EA to pieces for repair purposes is allowed only by professionally qualified persons trained in the production plant or by a contracted service centre!

6. Accessories and spare parts

6.1 Accessories

EA MO 5 and MOR 5 have neither accessory packed with .

6.2 The list of spare parts

Name of part - Type	Order number PNm	Pos.	Fig.
Micro-switch CHERRY DB6G-B1BA	64 051 219	20,21	5
Micro-switch CHERRY DB6G-A1LB	64 051 466	26,27	6,8
Resistive transmitter 1x100Ω	64 051 812	92	9
Resistive transmitter 1x2000Ω	64 051 827	92	9
Resistive transmitter 2x100Ω	64 051 814	92	9
Resistive transmitter 2x2000Ω	64 051 825	92	9
CPT transmitter	64 051 781	95	12
Converter	According to version	-	10,11
Casing KU 40x30	63249037	75	2
Casing KU 14x12	63243150	76	2
Ringlet 10 x 6	62732022	66	2
Sealing ring 16 x 28 x 7	62735044	70	2
Sealing ring 40 x 52 x 7	62735043	68	2
Ringlet 32 x 2	62731015	77, 34	2
Ringlet 110 x 3	62732116	-	1
Ringlet 125 x 3	62732114	-	1
Ringlet 130 x 3	62732020	78	2
Sealing	04 A05 199	-	1
Cable glands	63 456 597	7	1
Terminal board EKL 0 EDS PA	63 456 710	58	3

7. Enclosures

7.1 Wiring diagrams

Wiring diagrams MO

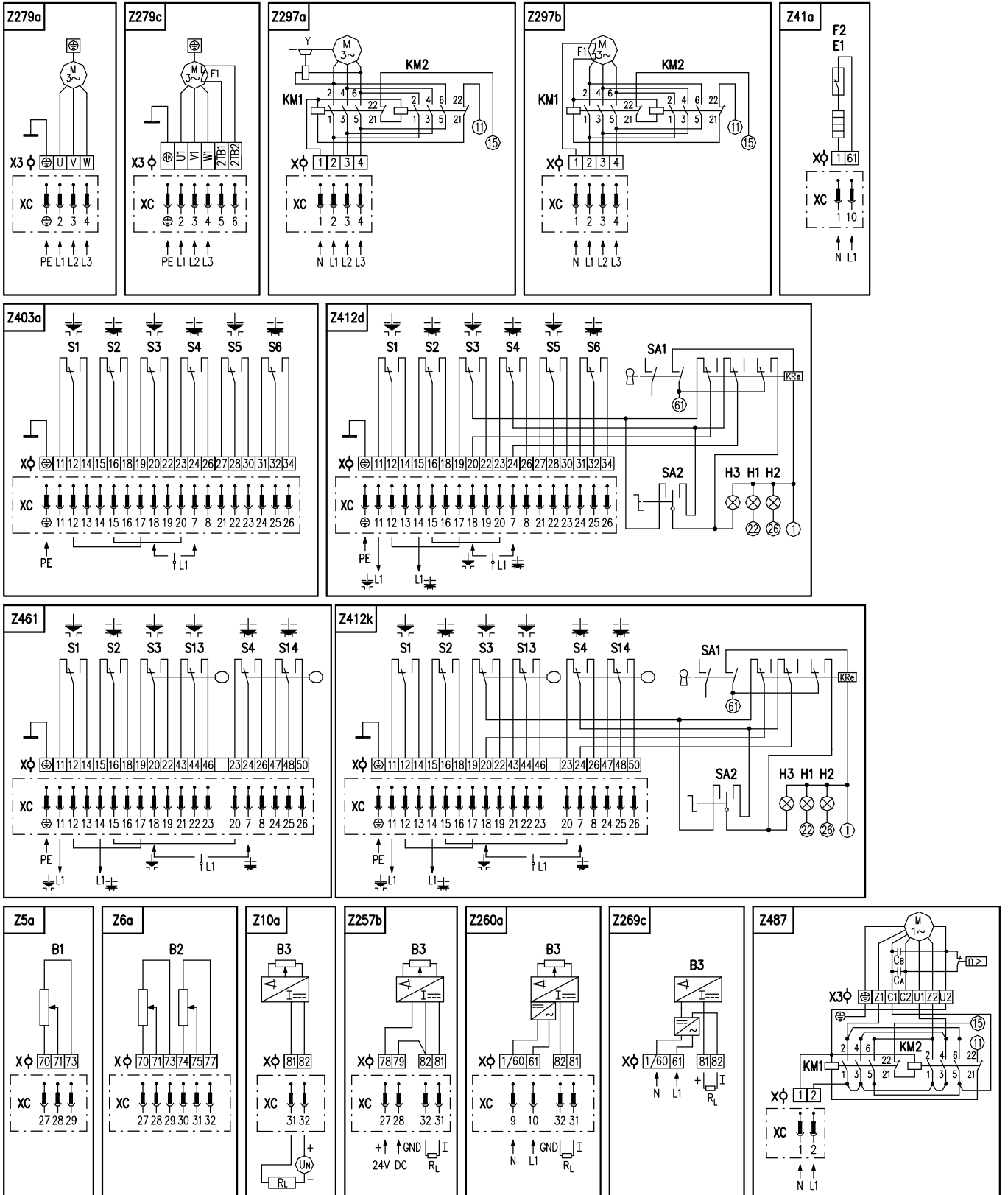

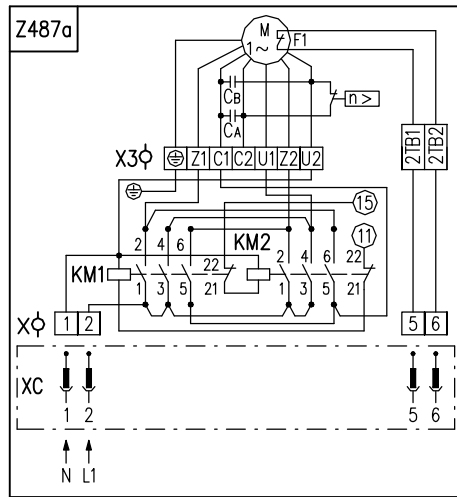
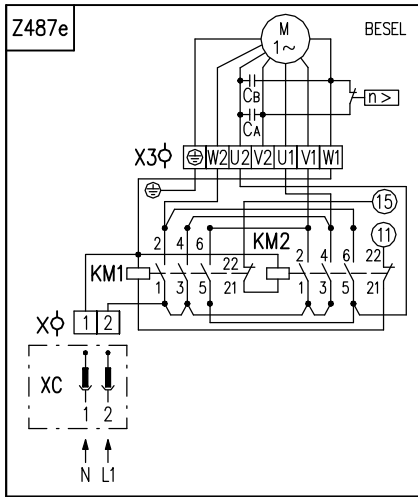

Wiring diagrams MO with controller

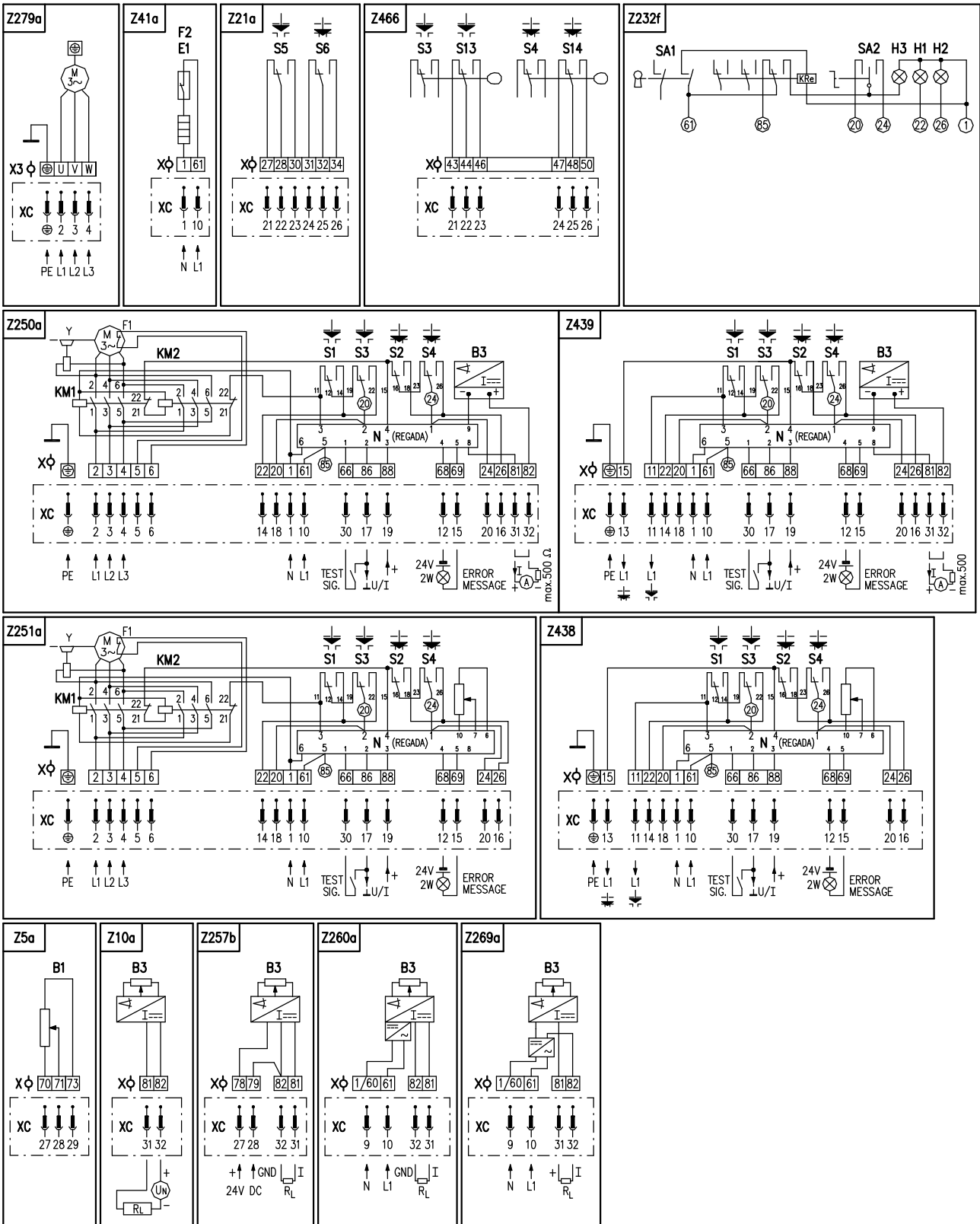

Legend:

Z279a.....	connection of 3-phase electric motor without contactors		
Z279c.....	connection of 3-phase electric motor with thermal protection		
Z297a.....	connection of 3-phase electric motor with contactors		
Z297b.....	connection of 3-phase electric motor with reverse contactors and thermal protection		
Z403a.....	connection of torque and position switches		
Z412d.....	connection of torque and position switches with electric local control		
Z461.....	connection of torque and position switches with tandem position switches		
Z412k.....	connection of torque and position switches with tandem position switches and with electric local control		
Z466.....	connection of tandem position switches for EA MO with controller		
Z5a.....	connection of single resistive transmitter		
Z6a.....	connection of double resistive transmitter		
Z10a.....	connection of resistive with current converter or capacitive transmitter – 2-wire without supply		
Z257b.....	connection of resistive transmitter with current converter – 3-wire without power supply		
Z260a.....	connection of resistive with current converter – 3-wire with power supply		
Z269a.....	connection of resistive transmitter with current converter or capacitive transmitter – 2-wire with power supply		
Z269c.....	connection of resistive transmitter with capacitive transmitter – 2-wire with power supply		
Z21a.....	connection of additional position switches connection for EA MO with controller		
Z41a.....	connection of space heater and space heater's thermal switch		
Z232f.....	connection of electric local for EA MO with controller		
Z251a.....	connection of EA MO with controller with resistant feedback for 3-phase electric motor with contactors		
Z250a.....	connection of EA MO with controller with current feedback for 3-phase electric motor with contactors		
Z438.....	connection of EA MO with controller without resistant feedback for 3-phase electric motor without contactors		
Z439.....	connection of EA MO with controller without current feedback for 3-phase electric motor without contactors		
Z487, Z487a, Z487e...	connection of EA with 1-phase electric motor.		
B1.....	resistive transmitter (potentiometer) single	SA1.....	rotary switch with key "remote – 0 – electric local" control
B2.....	resistive transmitter (potentiometer) double	SA2.....	rotary switch "opening – stop – closing"
B3.....	capacitive transmitter or resistive with current converter	S1.....	torque switch "open"
E1.....	space heater	S2.....	torque switch "closed"
F1.....	motor's thermal protection (not valid for this type of the EA)	S3.....	position switch "open"
F2.....	space heater's thermal switch	S4.....	position switch "closed"
H1.....	indication of "open" limit position	S5.....	additional position switch "open"
H2.....	indication of "closed" limit position	S6.....	additional position switch "closed"
H3.....	indication of "electric local control"	S13.....	tandem position switch "open"
I/U.....	input / output current (voltage) signals	S14.....	tandem position switch "closed"
M.....	electric motor	X.....	terminal board
N.....	controller	X3.....	electric motor's terminal board
R _L	loading resistor	XC.....	connector
		Y.....	motor's brake (not valid for this type of the EA)
		KM1, KM2...	reverse contactor

Notes:

1. In case, that output signal from the capacitive transmitter (wiring diagram Z250a, Z439) is not used (incomplete circuit between terminal 81 and 82), it is required to connect clamps 81 and 82 by jumper (jumper is connected at manufacturing plant for connecting to terminal board only). By using output current signal from capacitive transmitter it is needed to remove jumper.
2. With the version with controller when the feedback from the CPT transmitter is used; at using the output t signal, this signal isn't galvanic insulated from the input signal !
3. The torque tripping is equipped with a mechanical interlocking mechanism.
4. In case that galvanically separated output signal is needed it is necessary to use galvanical separation element (is not part of delivery), e.g. NMLSG.U07/B (producer SAMO Automation s.r.o.). After discussion this module could be supplied by EA producer.

7.2 Switch operation chart

Switch	terminals	Open		close	
				operating stroke	
S1	11 (M2) - 12				
	12 - 14				
S2	15 (M3) - 16				
	16 - 18				
S3	19 - 20				
	20 - 22				
S4	23 - 24				
	24 - 26				
S5	27 - 28				
	28 - 30				
S6	31 - 32				
	32 - 34				
S13	43 - 44				
	44 - 46				
S14	47 - 48				
	48 - 50				

■ Closed contact

□ Opened contact

Remark 1: The S1, S2 torque switches trip when the set up tripping torque is achieved doesn't matter in which point of the working stroke, it doesn't apply for the set up range of interlocking during EA reversal from any position

Remark 2: The S5, S6 signaling switches are settable within the range from the end position up to a position corresponding to the 50% of the working stroke. If a larger range for signaling purposes is necessary, the reversal function of the switches is available.

Remark 3: Tandem position switches S13, S14 are switched by one cam together with position switches S3, S4.

4 x tooth

F10 – shape D

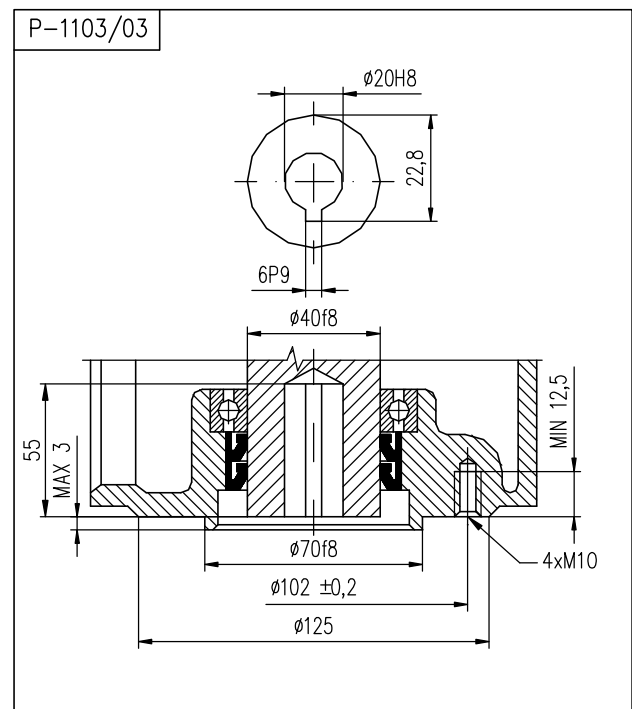
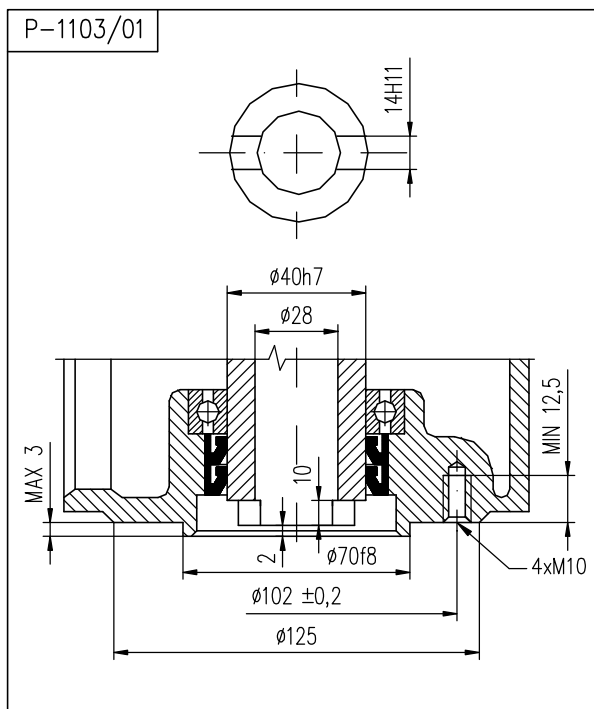
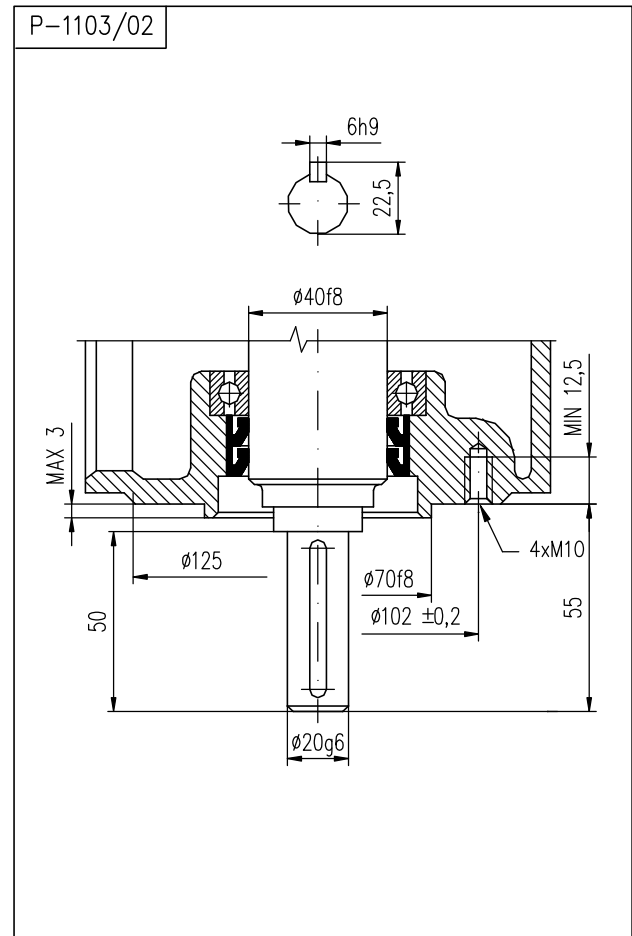
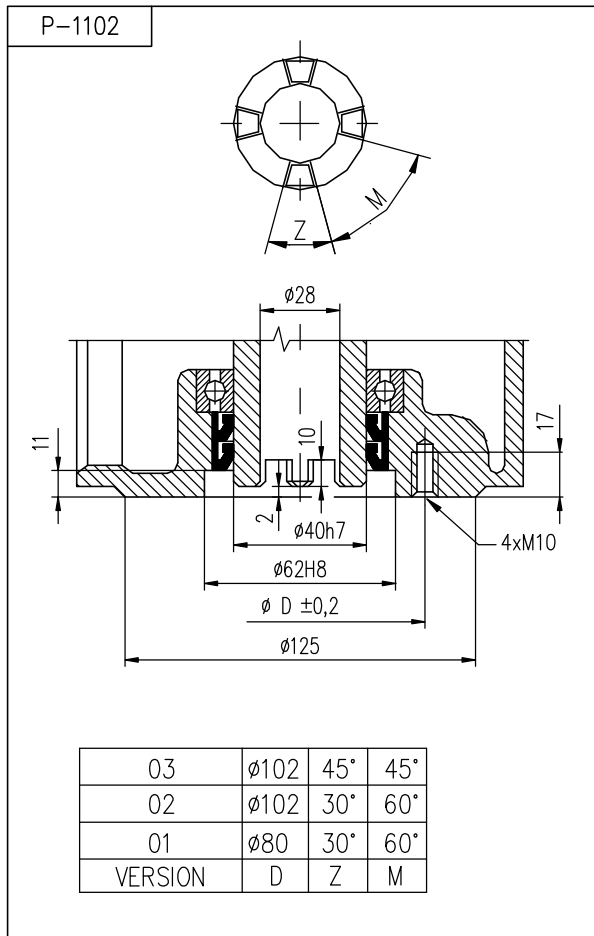

F10 – shape C; DIN 3338

F10 – shape E; ISO 5210

Mechanic connections for EA MO 3

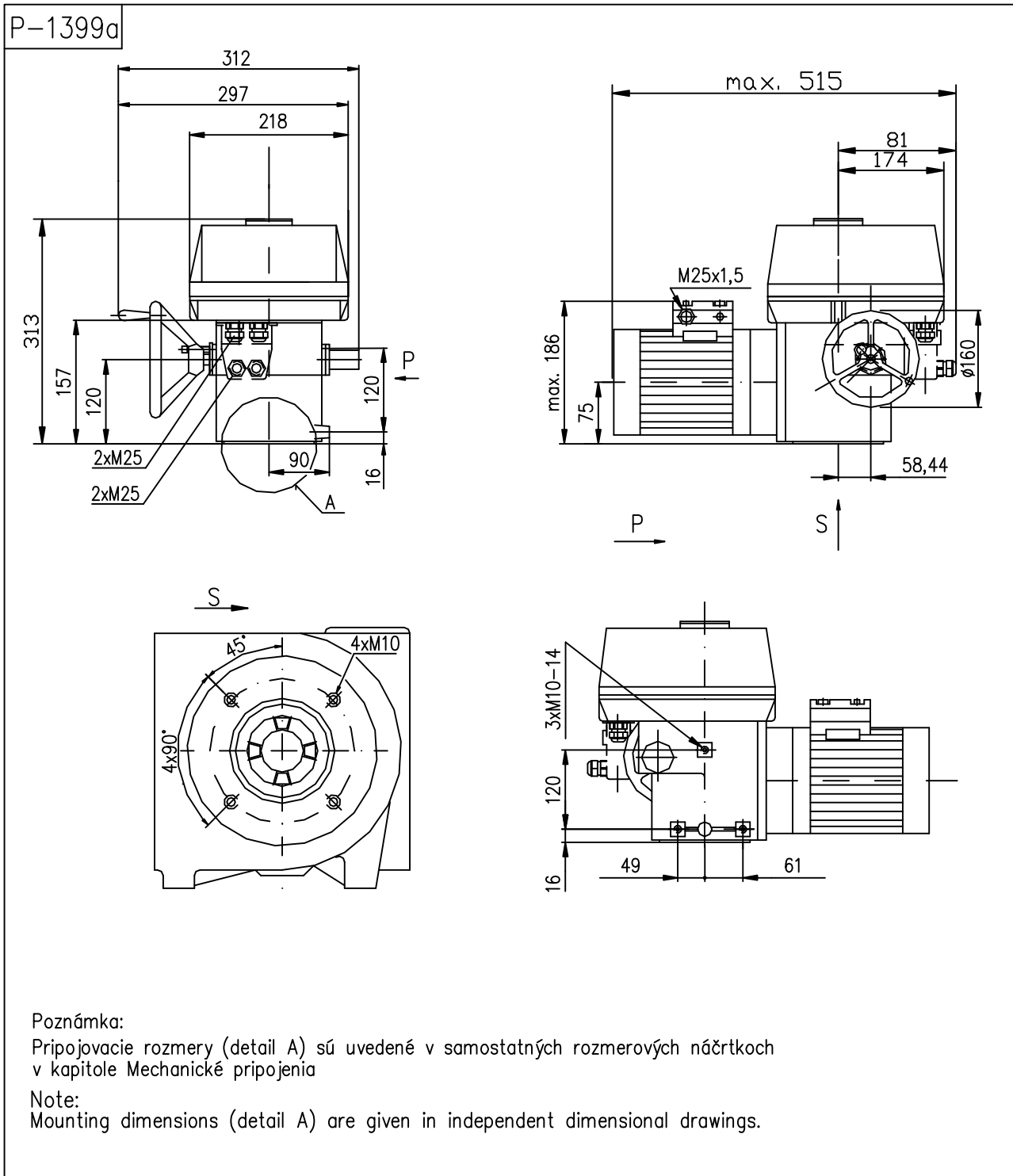

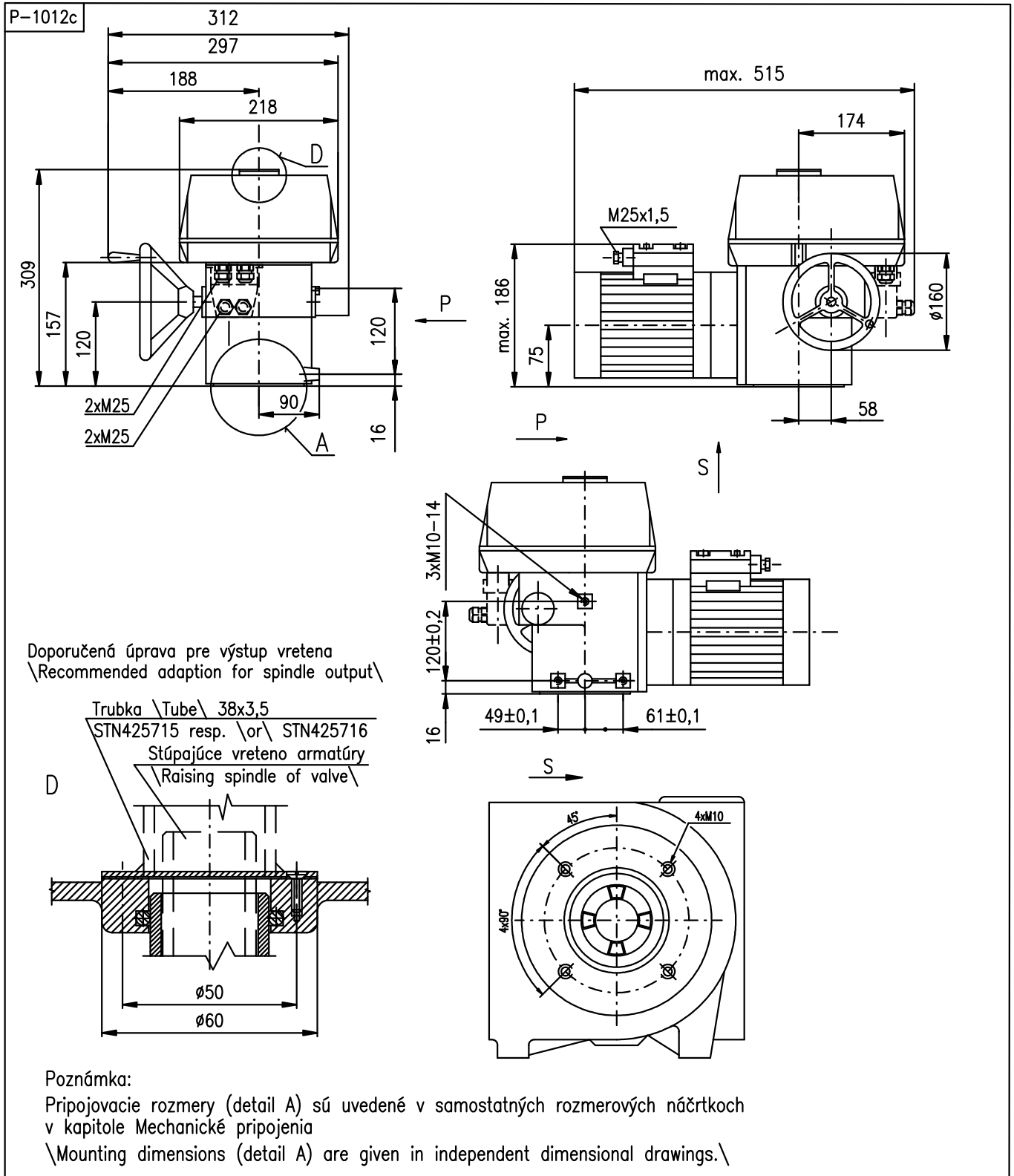

Mechanic connections for EA MO 3 with connect adapter

F10 – shape A

F14 – shape C

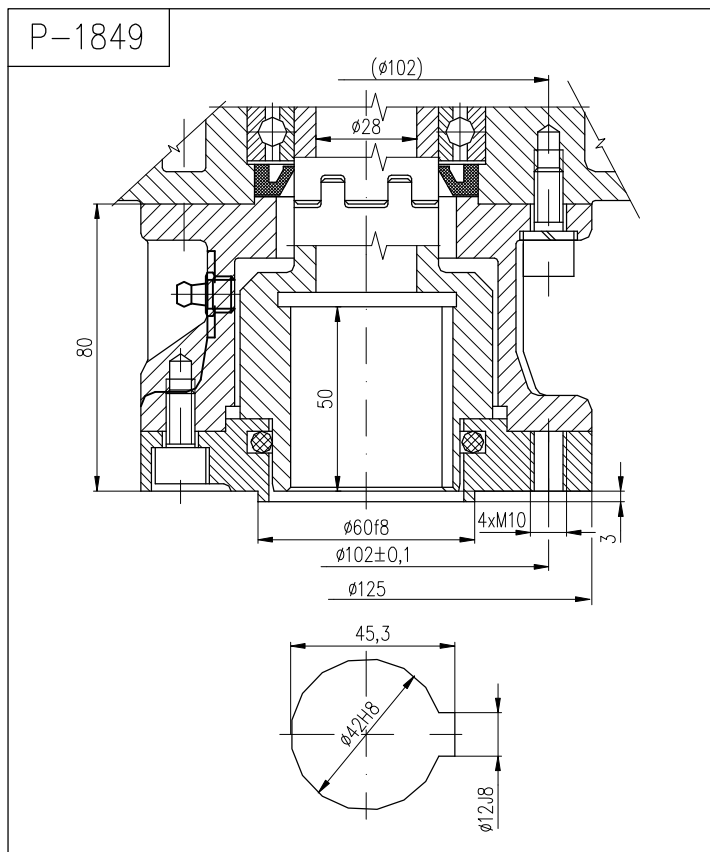
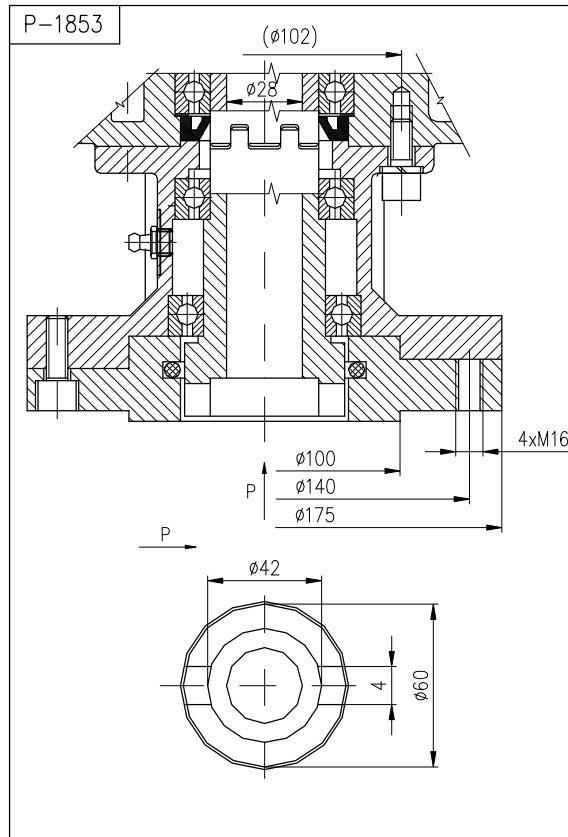
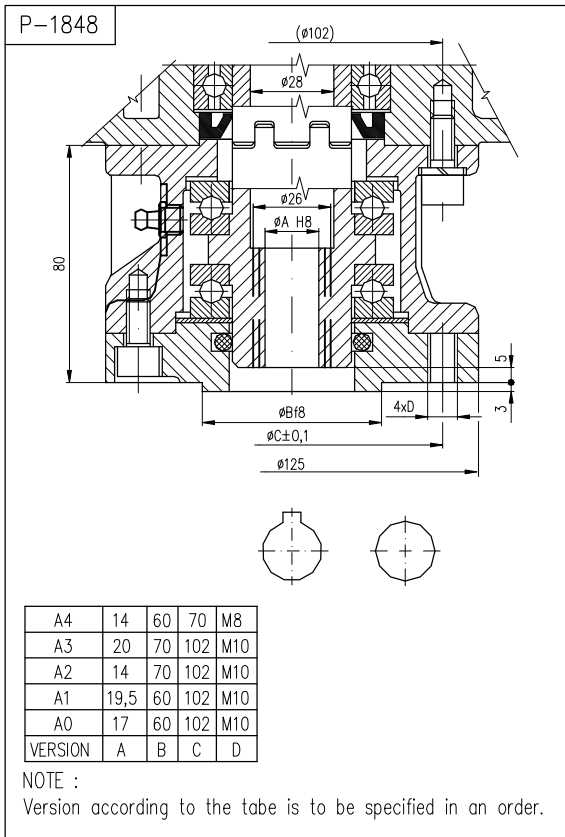

F10 – shape B1; ISO 5210

Dimension drawings for EA MO 3.5

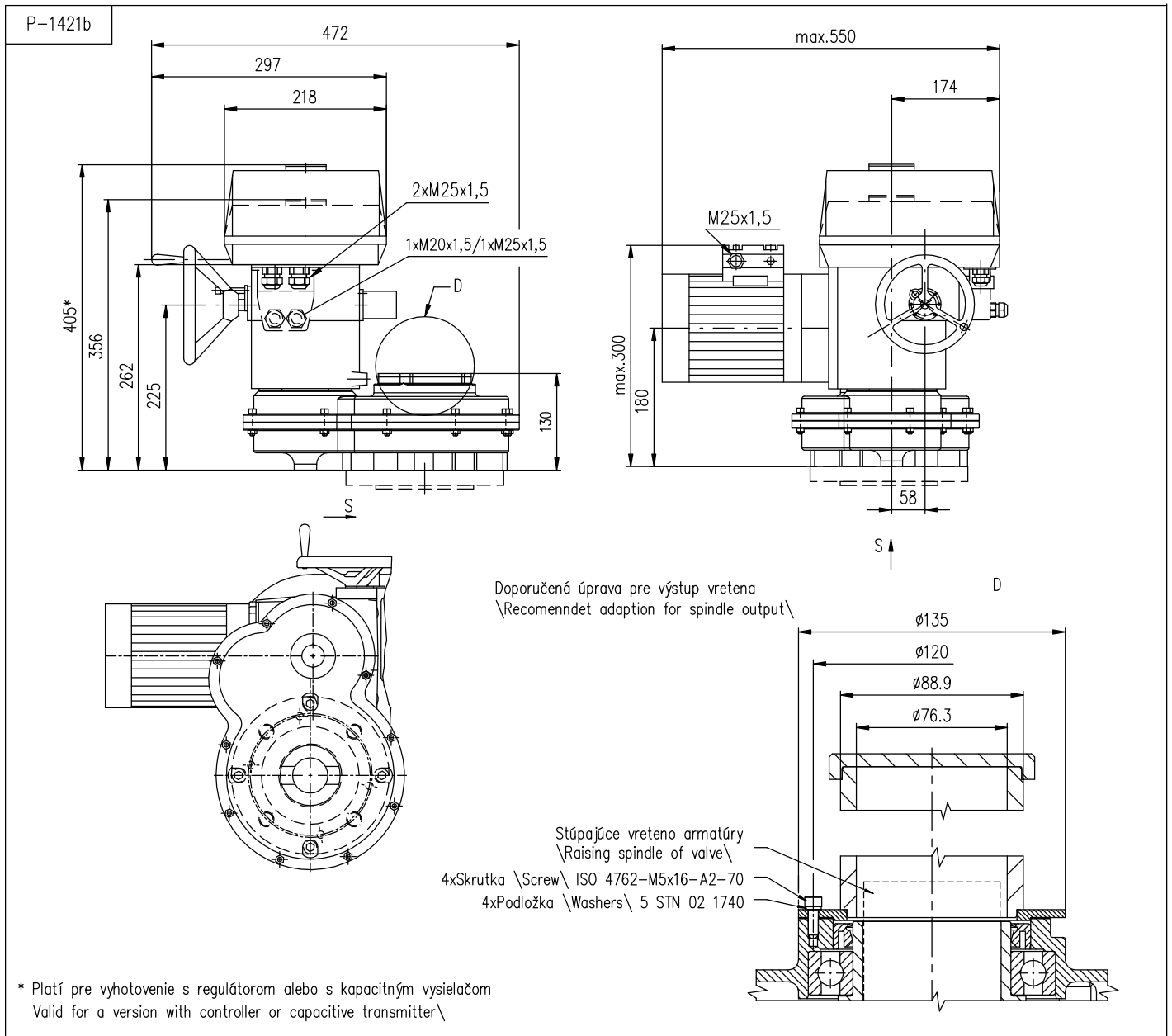

Dimension drawings for EA MO 3.4

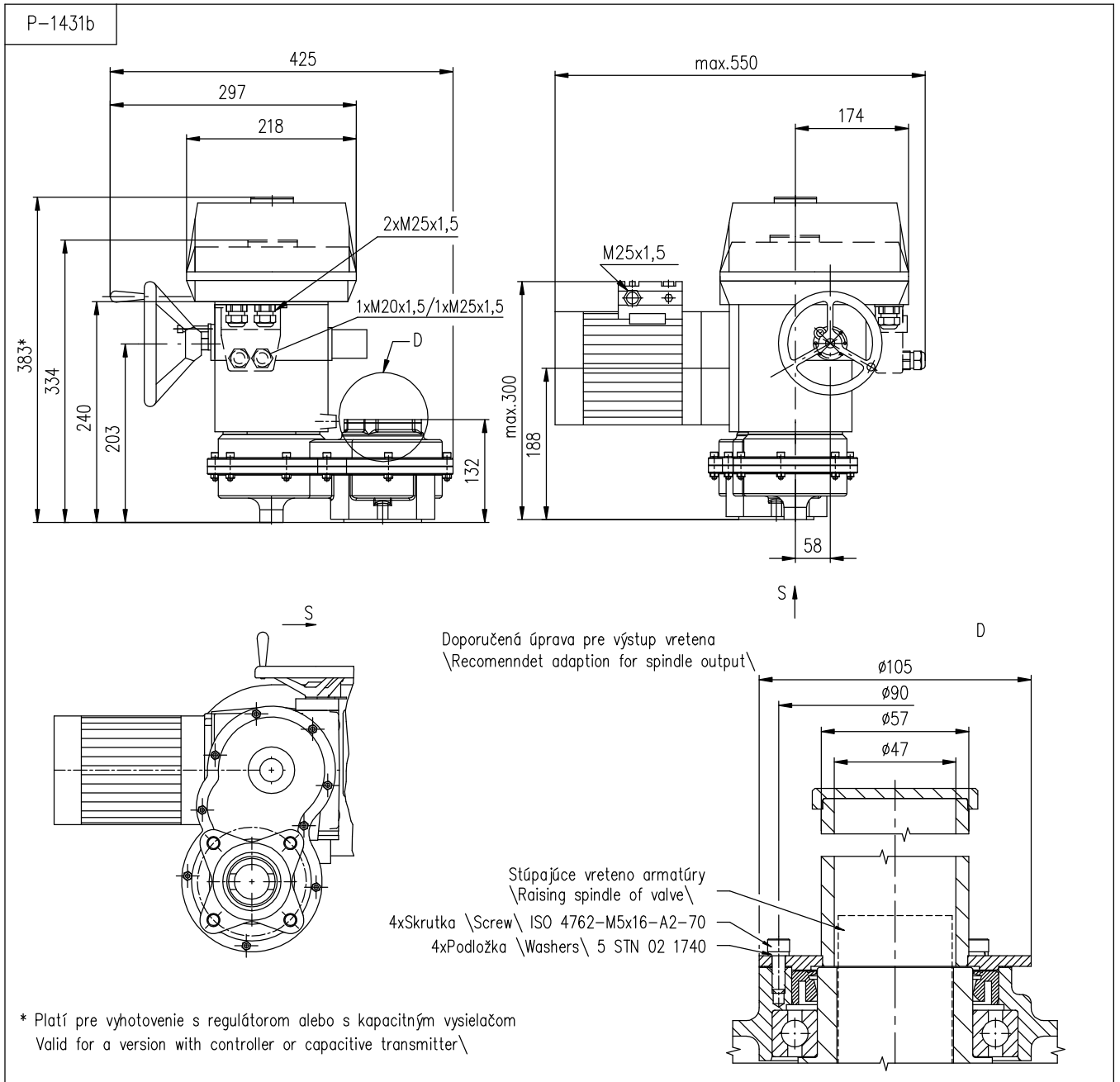

Dimension drawings for EA MO 3.3

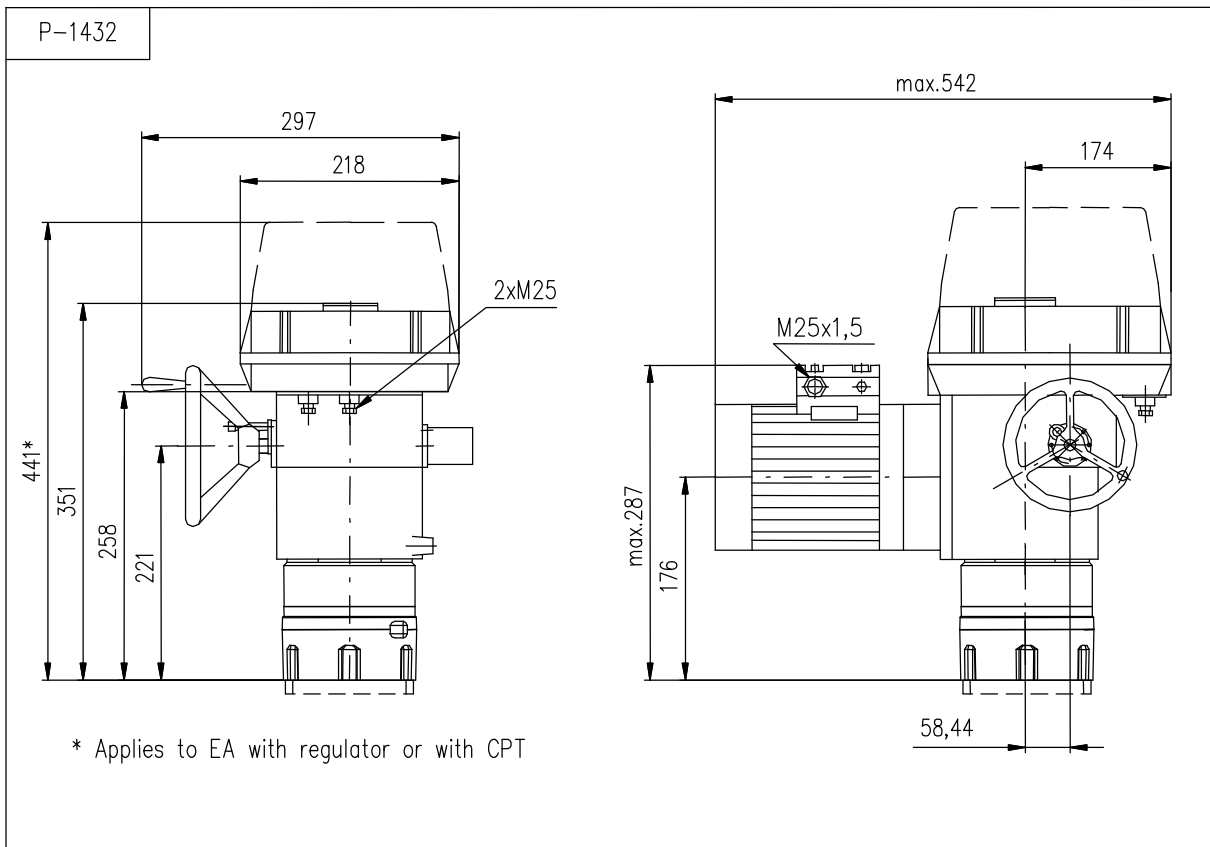

Mechanic connections for EA MO 3.3 without connect adapter

shape 5 tooth 35°/37°; GOST R 55510

shape C; DIN 3338

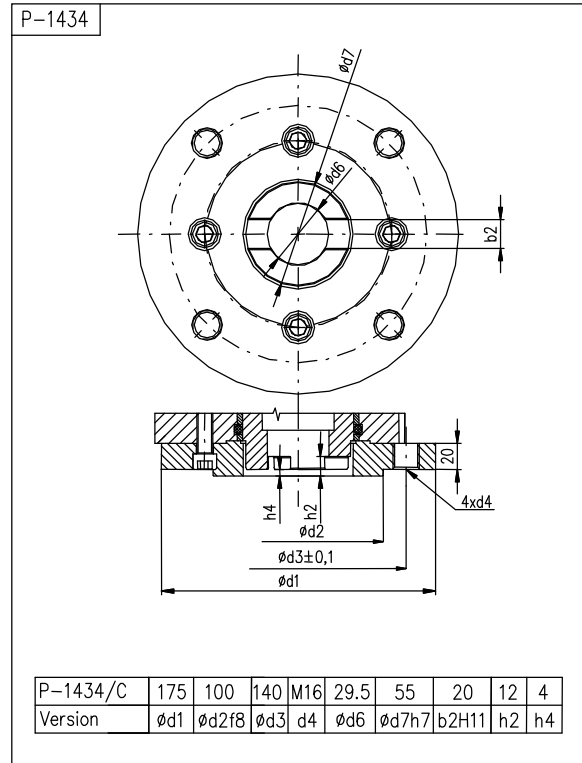
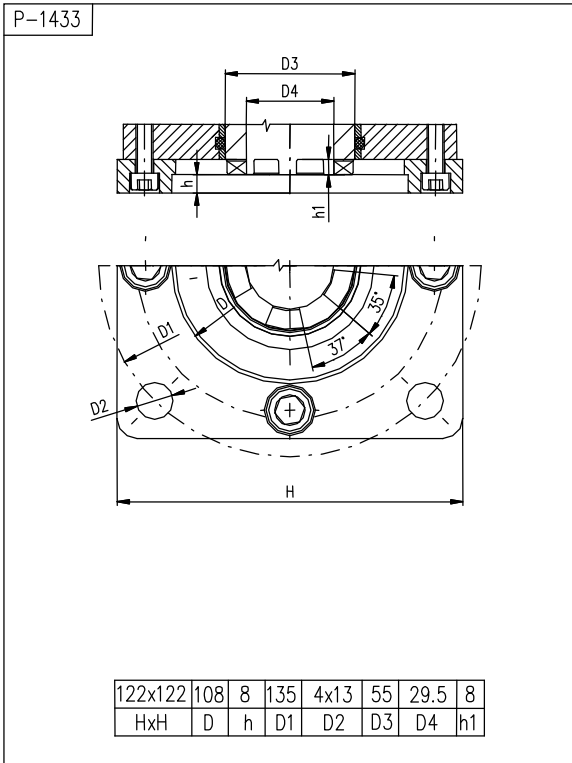

Mechanic connections for EA MO 3.4 without connect adapter

shape C; DIN 3338

5 tooth 35°/37° ; GOST R 55510

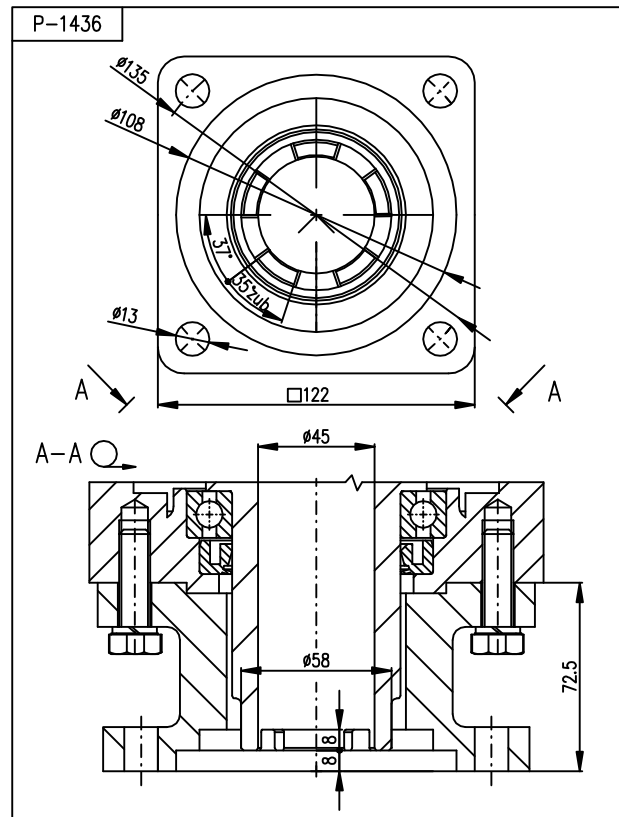
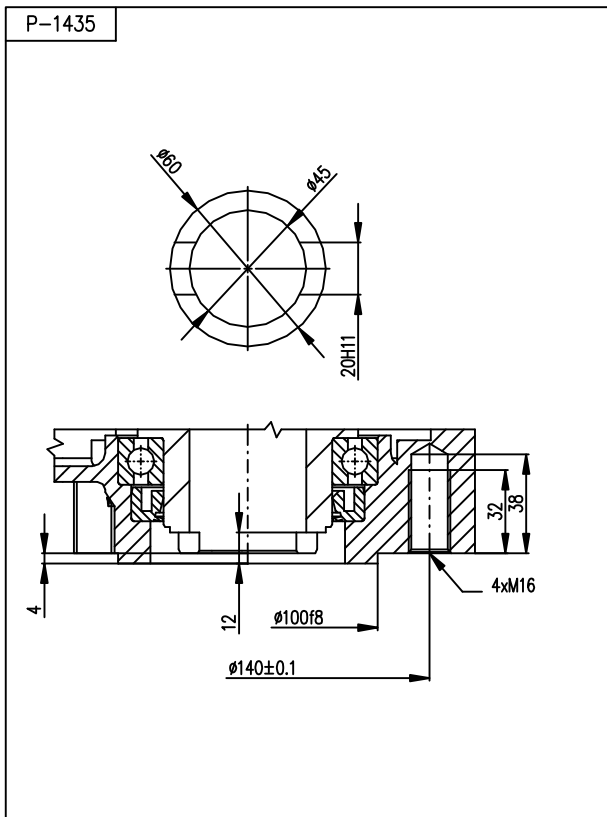

shape D

shape B2; B3; ISO 5210

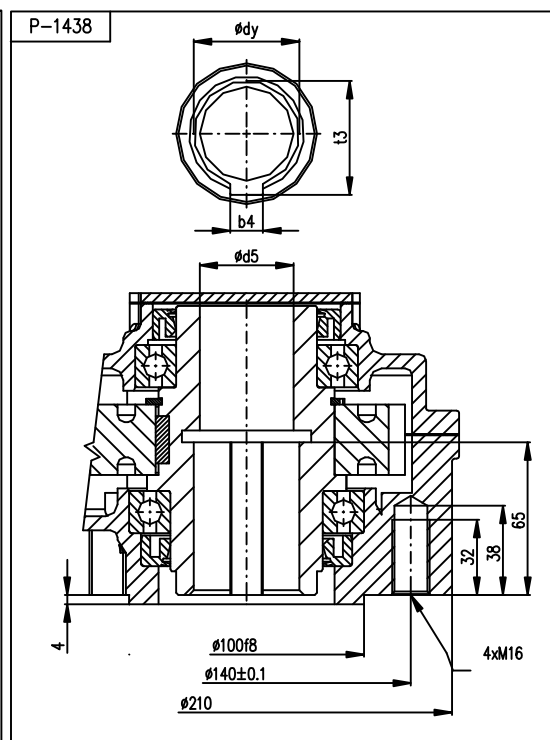
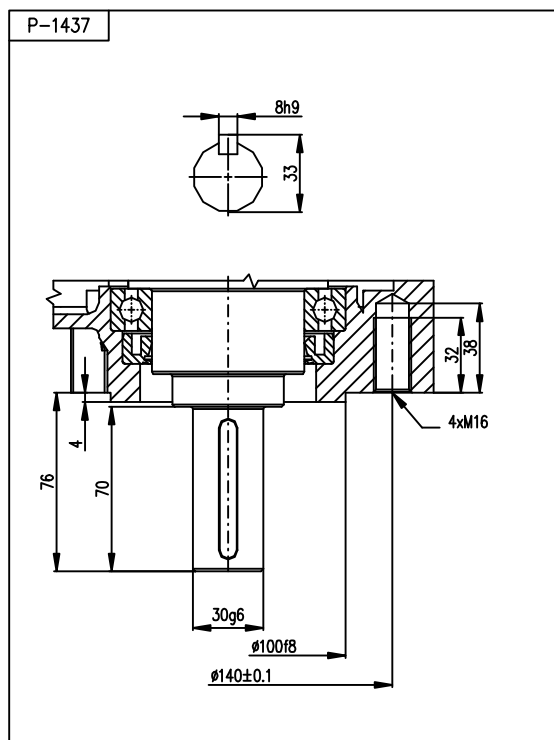

P-1438/N	45	40	14	48.6
P-1438/L	30	-	8	33.3
VERSION	dyH9	d5	b4Js9	t3

Mechanic connections for EA MO 3.4 with connect adapter

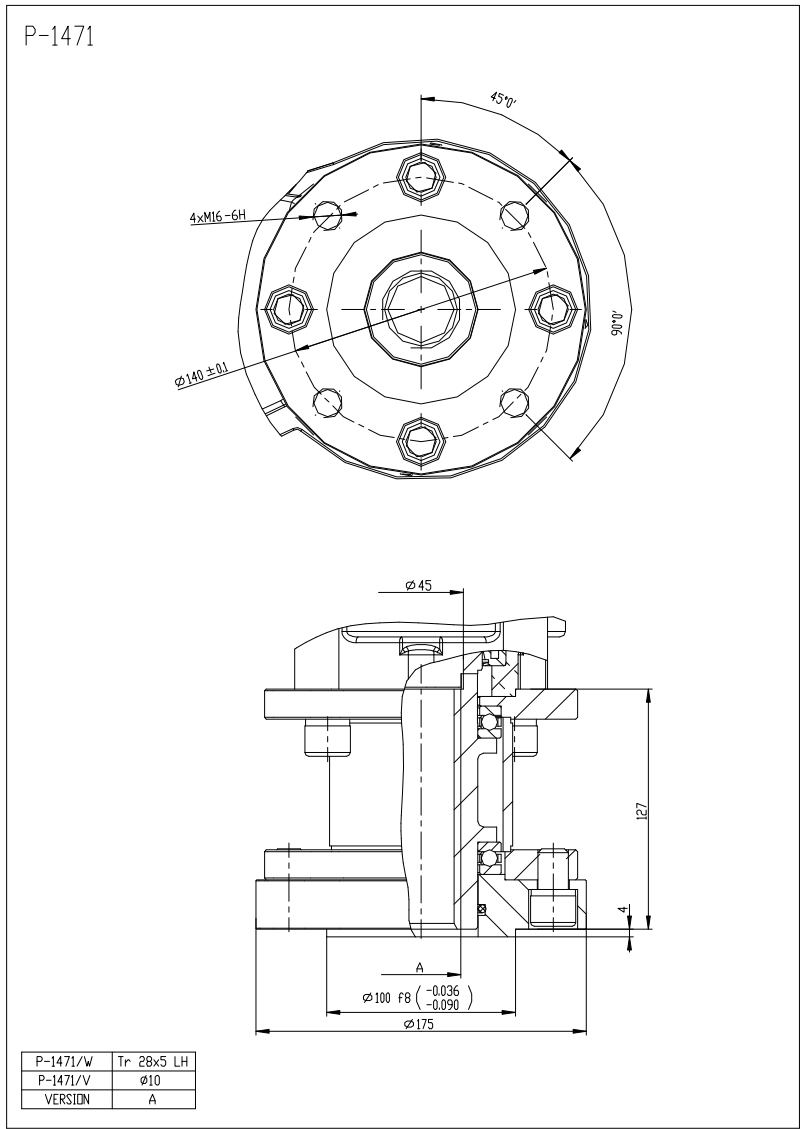

Mechanic connections EA MO 3.5 without connect adapter

shape C; DIN 3338

shape 5 tooth 35°/37°; GOST R 55510

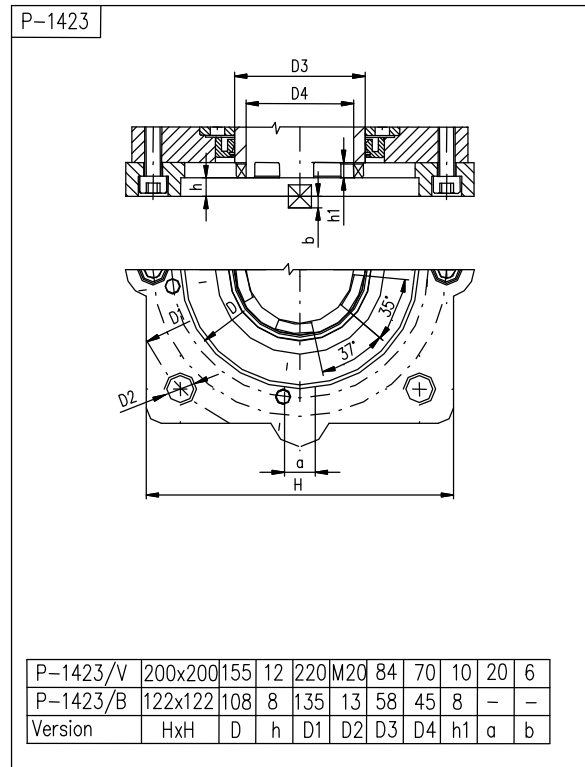
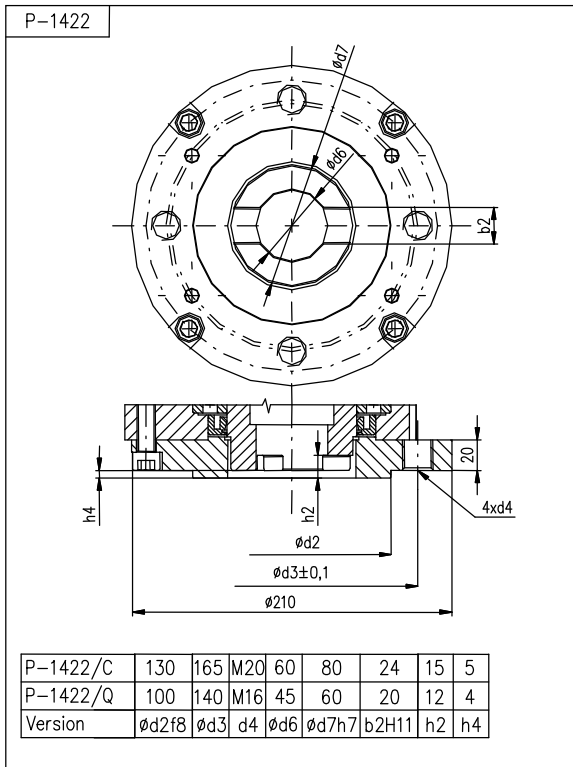

shape D

shape B1; B2, B3; ISO 5210

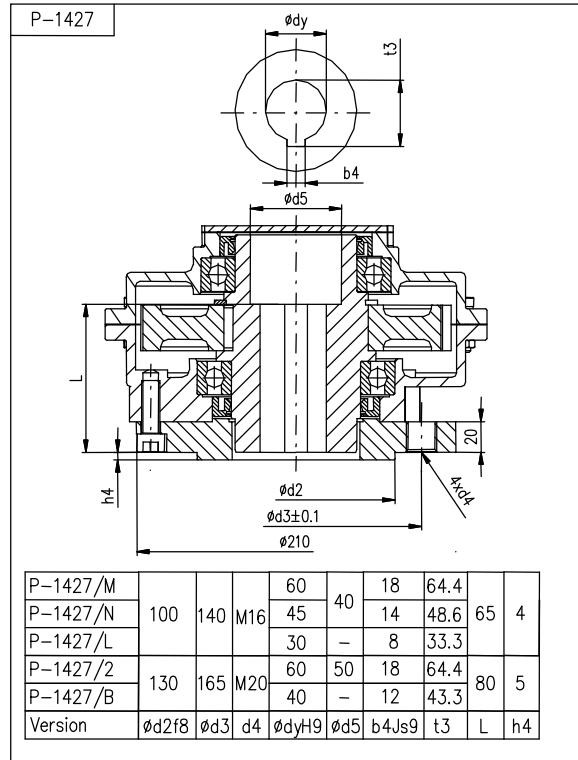
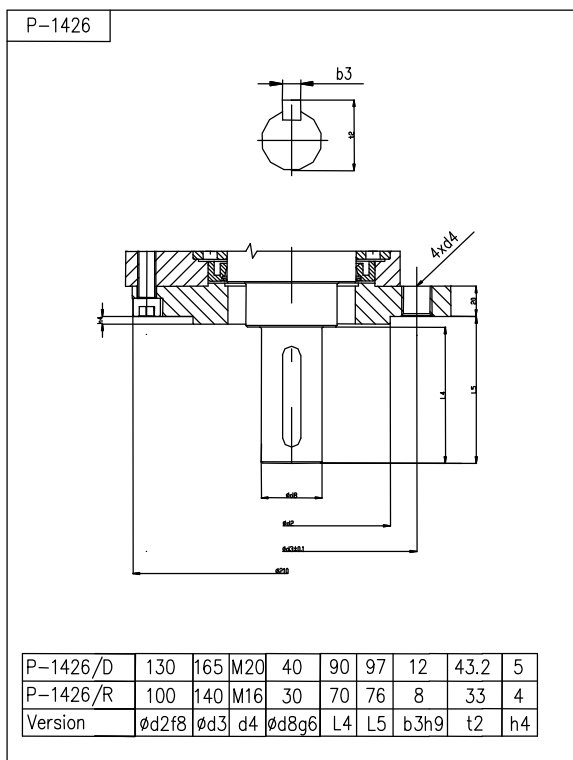

Mechanic connections for EA MO 3.5 with connect adapter
 F14 – shape A; ISO 5210

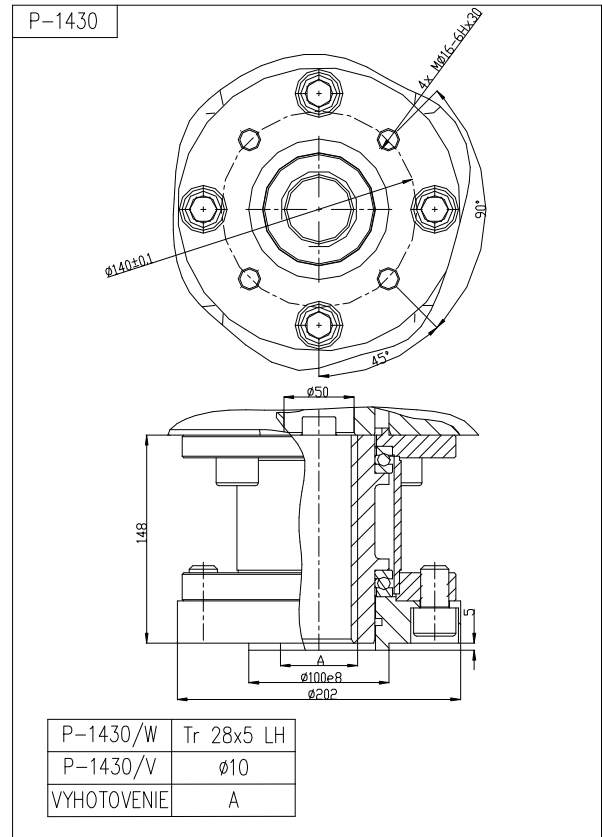
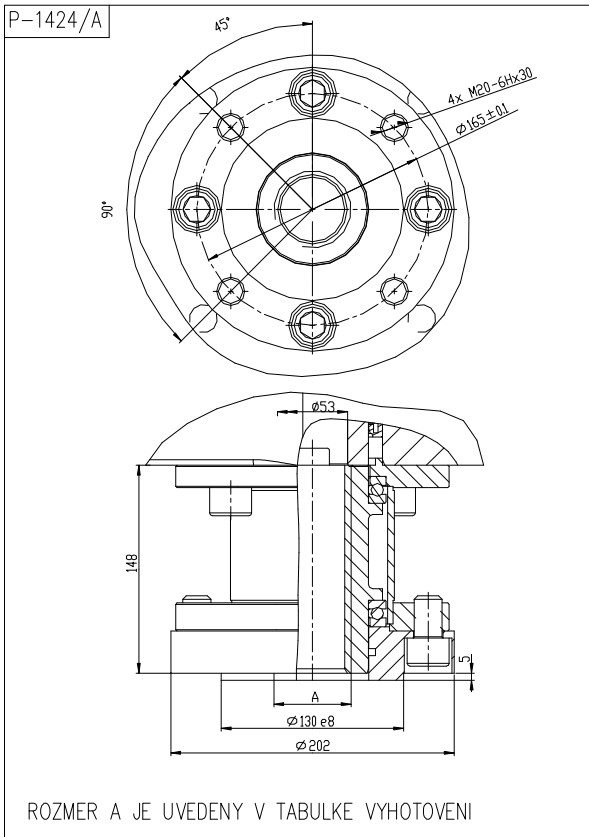

7.4 Guarantee service check report

<i>Service center:</i>	
<i>Date of repair:</i>	<i>Guarantee repair no.:</i>
<i>User of actuator:</i>	<i>Claim applied by:</i>
<i>Actuator type number:</i>	<i>Actuator production number:</i>
<i>Product claim fault:</i>	<i>Detected product fault:</i>
<i>Used spare parts:</i>	
<i>Remarks:</i>	
<i>Issued on a day:</i>	<i>Signature:</i>

7.5 Post guarantee service check report

<i>Service center:</i>	
<i>Date of repair:</i>	
<i>User of actuator:</i>	<i>Actuator operating place :</i>
<i>Actuator type number:</i>	<i>Actuator production number:</i>
<i>Detected product fault:</i>	
<i>Used spare parts:</i>	
<i>Remarks:</i>	
<i>Issued on a day:</i>	<i>Signature:</i>

7.6 Commercial representation

Slovak Republic:

Regada, s.r.o.,
Strojnícka 7,
080 01 Prešov
Tel.: +421 (0)51 7480 460,
Fax: +421 (0)51 7732 096,
E-mail: regada@regada.sk

Czech Republic:

Exclusive representation Regada, s.r.o. (Ltd.) for sale of electric actuators

Regada Česká, s.r.o.
Nám. 5. května 17,
252 25 Jinočany,
PRAHA – západ,
Tel.: +420 257 961 302
Fax: +420 257 961 301