



INSTALLATION, SERVICE AND MAINTENANCE INSTRUCTIONS



Electric multi-turn actuators SO 2

TEST CERTIFICATE

ELECTRIC MULTI-TURN ACTUATOR SO 2	
Type number 062.	Power supply V Hz
Serial number	Max. load torque Nm
Production year	Switching-off torque Nm
Wiring diagram	Operating speed min ⁻¹
.....	Adjusted number of revolutions
Warranty period months	Transmitter
Serial number of electric motor	
Serial number of transmitter.....	
Tests made in accordance with TP 74 1172 00	
Tests made by	Packed by
Date	Signature and stamp

COMPLETENESS CERTIFICATE

Used valve	
Assembled by: Firm	
Name.....	
Warranty period months	
Date	Signature and stamp.....

INSTALLATION CERTIFICATE

Location	
Installed by: Firm	
Name	
Warranty period..... months	
Date	Signature and stamp.....

Contents

1. General Information.....	2
1.1 Purpose and Application	2
1.2 Safety Instructions	2
1.3 Data specified on electric actuator	3
1.4 Warranty Conditions.....	3
1.5 Under-Guaranty and After-Guaranty Service.....	3
1.6 Operation Conditions.....	4
1.7 Conservation, packing, transport, storing and unpacking	6
1.8 Assessment of the product and packaging and removal of contamination.....	6
2. Description, Functioning and Specifications.....	7
2.1 Descriptions and Functioning	7
2.2 Specifications	8
3. Installation and Dismantling of the Actuator	11
3.1 Installation	11
3.2 Dismantling.....	15
4. Adjustment.....	15
4.1 Adjustment of the Torque Unit.....	15
4.2 Adjustment of position-signalling unit (S3(S13),S4(S14)) (Fig.3)	16
4.3 Signaling switches adjustment (S5,S6) (Fig. 8)	18
4.4 Position indicator adjustment (Fig.8)	18
4.5 Adjustment of resistant transmitter (Fig.4)	19
4.6 Adjustment of the Electronic Position Transmitter (EPV) - the Resistive Transmitter (Potentiometer) with the Converter PTK 1	20
4.7 Adjustment of the DCPT3M transmitter	22
5. Service and Maintenance	25
5.1 Service.....	25
5.2 Maintenance – Its Scope and Periodicity	26
5.3 Troubleshooting.....	27
6. Accessories and Spare Parts	28
6.1 List of the Spare Parts	28
7. Enclosures.....	29
7.1 Wiring diagrams SO 2	29
7.2 Switch operation chart.....	32
7.3 Dimensional drawings	33
7.4 Guarantee service check report	43
7.5 Post guarantee service check report.....	44
7.6 Commercial representation	45

1. General Information

1.1 Purpose and Application

Electric multi-turn actuators (hereafter referred to as **EA**), types **SO 2** are high performance electro-mechanical products, designed for direct assembly on controlled devices. EA of SO 2 types are provided for remote control of closing bodies. They are equipped by measuring and technological processes controlling means; the information carrier on their input and/or output is unified analogue direct current, or voltage signal. They can be used in heating, energy, gas, air-conditioning and other technological equipments, for which are suitable due to their manufacturing qualities. They are assembled by means of flange and connecting component in accordance with ISO 5210, DIN 3338, resp. GOST R 55510.



1. It is forbidden to use the EA as a lifting mechanism!
2. Switching of actuator by a semiconductor components/switches have to be consulted with producer.

1.2 Safety Instructions



EA of SO 2 types are reserved technical devices with higher rate of danger, with possibility of installation in areas specially danger regarding casualties caused by electric current.

Electric actuators are according to directive LVD 2014/35/EU and standard EN 61010- 2010+A1:2019 assigned for installation category II (overvoltage category), pollution degree 2.

Effects of the Products upon Environment

Electromagnetic compatibility (EMC): the product complies with the requirements of the Directive 2014/30/EU of the European Parliament and of the Council on the approximation of the laws the Member States relating to the electromagnetic compatibility and with the requirements of standards as well EN IEC 61000-6-4, EN IEC 61000-6-2, EN IEC 61000-3-2 and EN 61000-3-3+A1 in accordance with valid certificates.

Vibrations caused by the product: the product invokes negligible vibrations

Noise produced by the product: The maximum allowable noise level (A) of the product measured in a place of operation is 78dB (A).

Requirements for professional qualification of people performing installation, service and maintenance



Electric connection can be performed only by an acquainted person, i.e. an electrical engineer with professional education of electrical engineering at an apprentice school or a technical school (secondary, complete secondary or university education) and whose qualification was verified by an educational facility authorised to verify professional qualification.



Instructions for operating staff training

Operation can be performed by skilled personal only trained by production plant, resp. by contracting service center!

Warning for safe utilization

Protection of the Product

EA SO2 has no own protection against short circuit. That is why the power supply has to contain a suitable protection device (a breaker or a fuse) that can also serve as a main switch. For protection, we recommend to use a fuse type "T" or a contactor type "C".

Type of equipment from a connection point of view: The equipment is designed for permanent connection.

1.3 Data specified on electric actuator

Type plate:

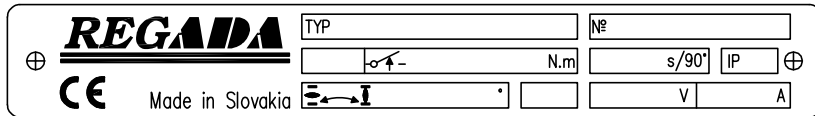







Warning plate:

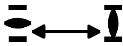

Type plate contains the basic data concerning identification, performance and electricity: indication of producer, type, serial number, max. load torque and switching-off torque, protection code, operating stroke, revolutions, supply voltage and current.

Graphic symbols on electric actuator

The graphic symbols used on electric actuator substitute the text messages. Some of them are in accordance with EN ISO 7010, ISO 7000 and IEC 60417.

	Dangerous voltage	(EN ISO 7010-W012)
	CAUTION! ¹⁾	(EN ISO 7010-W001)
	Stroke of the electric actuator	
	Switching-off torque	
	Manual control	(0096 ISO 7000)
	Protection terminal	(5019 IEC 60417)

¹⁾ See. chapter 3.1.2

1.4 Warranty Conditions

The supplier is responsible for the completeness of the delivery and warrants the parameters of the products that are stated by the technical conditions (TC) or the parameters agreed in the agreement.

The supplier is not responsible for decline of quality caused by the purchaser while storing, unprofessional installation or incorrect operation.

1.5 Under-Guaranty and After-Guaranty Service

All our products can be serviced by the professional service staff of our firm that provides installation, operation, service, checking and troubleshooting.

The under-guaranty service is provided by the service department of the producer on the basis of a written claim.

While claiming it is advised to present the following:

- basic data from the nameplate (type and serial numbers)
- period in operation, ambient conditions (temperature, humidity,...) operation mode including switching frequency, type of switching (position or thrust), adjusted switching thrust).
- a kind of failure - a description of the claimed failure
- a copy or a transcription of Installation Certificate.

It is advised to perform the **after-guaranty service** by the service department of the producer or by a contracted service firm.

1.5.1 Lifetime of actuators

The lifetime of an electric actuator (EA) is at least 6 years.

EA used for closing mode (closing valves) comply with the requirements for at least **15,000 working cycles** (cycle C – O – C at 30 revolutions per operating stroke:for multi-turn EA)

EA used for regulating/modulating operation (control valves) comply with the below stated numbers of **operating hours** at the total number of 1 million start-ups:

Switching frequency				
max. 1,200 [h ⁻¹]	1,000 [h ⁻¹]	500 [h ⁻¹]	250 [h ⁻¹]	125 [h ⁻¹]
Minimal lifetime expectancy – number of operating hours				
850	1,000	2,000	4,000	8,000

Time of **net operation** is min. 200 hours, max. 2,000 hours.

Lifetime at operating hours depends on loading and switching frequency.

Note: High switching frequency does not ensure better regulation. Setting of regulation parameters should be therefore made with the inevitably necessary switching frequency needed for the process in question.

1.6 Operation Conditions

1.6.1 Location of the Products and Operation Position

The EA can be built-in and operated in the sheltered places of industrial objects without any temperature or humidity control and with a protection against direct climate exposure (e.g. direct sunshine). except the special version designed for waste water treatment plants, water management, the selected chemical plants and tropic conditions.



Warning:

When the EA is installed in open air, **it must be** sheltered lightly to protect is against direct effects of atmosphere.

When installed in the areas with relative humidity more than 80%, in open air under a shelter it is needed to connect the space heater directly – without a thermal switch.

EA can be built-in and operated in any position. Standard position is with vertical axis of the output part and with the control part placed above.

1.6.2 Operation Environment

According to valid standard IEC 60 721-2-1, there are delivered these versions of electric actuators:

- 1) Version „**standard**“ for type climate temperate
- 2) Version „**tropical wet**“ for type climate tropical wet
- 3) Version „**cold**“ - for type climate cold
- 4) Version „**tropical dry and dry**“ for type climate tropical dry and dry
- 5) Version „**marine**“ for type climate marine
- 6) Version „**arctic**“ for type climate arctic.

In accordance with IEC 60 364-1, IEC 60 364-5-51 within valid edition the EA have to resist external effects and operate reliably:

In the conditions of the following types of environment:

- warm mild to very hot dry with temperature in range -25°C to +55°C AA 7*
- cold to warm mild and dry with temperatures in range -50°C to +40°C AA 8*
- cold to mild hot dry with temperatures in range -60°C až +40°C..... AA 1*+AA 5*
- with relative humidity 10 to 100 %, including the condensation of up to 0,029 kg water content per 1 kg of dry air, at above stated temperature..... AB 7*
- with relative humidity of 15÷100%, including the condensation of up to 0,036 kg water content per 1 kg of dry air, at above stated temperature..... AB 8*
- with relative humidity 5 to 100 %, including the condensation of up to 0,025 kg water content per 1 kg of dry, at above stated temperature AB 1*+AB 5*

- with height above sea level 2 000 m, with barometric pressure range 86 to 108 kPaAC 1*
- with spraying or jet water from all directions–(protection enclosure IP x5)AD 5*
- with shallow immersion – (protection enclosure IP x 7)AD 7*
- with submersion – (product with enclosure IPx8).....AD 8*
- with strong dustiness – with a possibility of influences of inflammable, non-conducted and non-explosive dust; the middle layer of dust; the dust drop more than 350 but not more than 1000 mg/m² per day (products with protection enclosure of IP 6x).....AE 6*
- with atmospheric occurrence of corrosive and pollution media (with high degree of atmosphere corrosive aggressiveness); important presence of corrosive pollution AF 2*
- with permanent exposure to either large quantity of corrosive or contaminating chemicals and salt mist; the version designed for marine conditions, waste water treatment plants and some chemical plants AF 4*
- with a possibility of influences of mechanical stress:
 - medium sinusoid vibrations with frequency in range 10 up to 150 Hz, with shift amplitude of 0,15 mm for $f < f_p$ and acceleration amplitude 19,6 m/s² for $f > f_p$; (transition frequency f_p is from 57 up to 62 Hz)AH 2*
 - medium impacts, shocks and vibrations AG 2*
- with serious danger of plants and moulds growing AK 2*
- with serious danger of animals occurrence (insects, birds, small animals) AL 2*
- with detrimental influence of radiation:
 - of stray current with intensity of magnetic field (direct and alternating of power supply frequency) to 400 A.m⁻¹AM 2-2*
 - of sun radiation with intensity > 500 a ≤ 700 W/m² AN 2*
- with effects of medium seismic activity with acceleration > 300 Gal ≤ 600 Gal AP 3*
- with indirect danger of storm activityAQ 2*
- with fast moving of air and strong winds AR 3 , AS 3*
- with persons frequent touching earth potential (persons often touch conductive parts or they stand on the conductive basement)BC 3*
- without any danger media with object BE 1*

* Marking in accordance with IEC 60364-1, IEC 60 364-5-51 and IEC 60 364-5-55 within valid edition

1.6.3 Power Supply and Operation Modes

Power supply:

Electric motor.....230/220 V AC $\pm 10\%$, 3x400/3x380 V AC $\pm 10\%$ resp. 24 V AC/DC $\pm 10\%$

Control part.....230 V AC $\pm 10\%$ resp. resp.24 V AC /DC $\pm 10\%$

Frequency of power supply 50 resp. 60** Hz $\pm 2\%$

** Stroke speed will increase 1,2 times, and torque will decrease 1,2 times

Duty cycles (according to EN/IEC 60 034-1 within valid edition):

EA SO 2 are designed for **remote control**:

- with short operation S2-10min
- with interrupted operation S4-25%, max. 90 cycles/hour

EA SO 2 with external controller are designed for **automatic control**

- with interrupted operation S4-25%, 90 to 1200 cycles/hour

Note: 1. The duty cycles consists of the kind of load, the loader and the frequency of switching.

2. Once EA SO 2 is connected to the external controller unit, also use it as a control EA where the maximum load torque reaches the 0.8 multiple of the maximum loading torque for remote operated EA SO2.

1.7 Conservation, packing, transport, storing and unpacking

Surfaces without surface treatment are treated by conservation preparation MOGUL LV 2-3 before packaging .

Conservation is not necessary if the following storage conditions are complied with:

- Storage temperature: -10 to +50 °C
- Relative air humidity max.80 %
- Electric actuators and their accessories must be stored in dry, well ventilated covered spaces, protected against impurities, dust, soil humidity (by placement to racks, or on palletes), chemicals and foreign interventions
- There shall be no corrosive gases present in the storage areas.

The **EA SO 2** are delivered in solid packages, assuring the resistance according to the requirements of standards EN 60654.

The package is made by a box. The products in the boxes can be packed on pallets (the pallet is returnable). The following information is given on the outside of the package:

- the producer
- the name and the type of the product
- number of pieces
- other data – inscriptions and labels.

The forwarder is obliged to protect the packed products loaded into transport means against spontaneous motion, in case of an open transport mean they are to be protected against rainfalls and flowing water. Location and fixing of the products in transport means should guarantee their fixed position, avoid possibility of mutual bumps and bumps against the walls of the transport means.

The transport in non-heated and non-pressurized transport means with conditions in range:

- temperature: -25°C to +70°C (special versions –50°C to +45°C)
- humidity: 5 to 100% with maximum water content of 0.028 kg/kg of dry air
- barometric pressure: 86 to 108 kPa .

After receiving of the EA check whether during their transport or storing no damage occurred. Compare the data on their nameplates with the accompanying documentation/the purchase agreement (the order). In case of any discrepancy, failure or damage inform about the fact the producer immediately.



If not installed immediately the EA and their equipment should be stored in dry, well-conditioned sheltered areas, protected against impurities, dust and soil humidity (with keeping them on shelves or pallets), chemical and unauthorized impacts, at ambient temperature from -10°C to +50°C and at relative air humidity max. 80 %, in special version at temperature –50°C do +40°C.

- It is forbidden to store EA outside or in areas not prevented against direct impact of climate.
- Strains of the surface finishing should be promptly removed if any – it can prevent the product against corrosion damages.
- While storing more than one year it is necessary to check lubrication filling before the actuator is put into operation.
- The EA installed but not operated are to be protected the same way as when storing (e.g. with a wrapping).
- After it is mounted onto a valve in free and wet areas or in areas where temperature is changing it is necessary to connect the space heater – to prevent the actuator against corrosion resulted from water condensed in the control part.
- Remove odd conservation grease as late as before putting into operation.

1.8 Assessment of the product and packaging and removal of contamination

The product is made of recyclable. The single parts of the package and the product should not be thrown away after its lifetime but sorted according to the related regulations and rules about environment protection and delivered for next treatment.

The product itself as well as its package is not a source of spoiling of environment and they do not contain any dangerous waste.

2. Description, Functioning and Specifications

2.1 Descriptions and Functioning

The EA **SO 2** are of the compact design with several connected modules. They consist of two functionally different main parts.

The gear part is made of flange with a coupling for connection with the controlled part and gearings placed in the bottom case; on the opposed side there are led drive mechanisms for units of the controlled part.

The control part (Fig. 1) is located on the control board (1), which contains:

- an electric motor (2) (for the single-phase version it is with a capacitor)
- a torque unit (5) – controlled by axial motion of a worm gear
- a position-signalling unit (3) with a mechanical local position indicator (4)
- an electronic position transmitter (12)
- a position transmitter (13)
- a space heater with) with thermal switch. (11)
- electric connection is realised using **terminal boards** (10) (located in the control area) and cable bushings with cable bushings

Additional accessories:

Manual control: made up by a handwheel with a worm gearing.

Electric local control

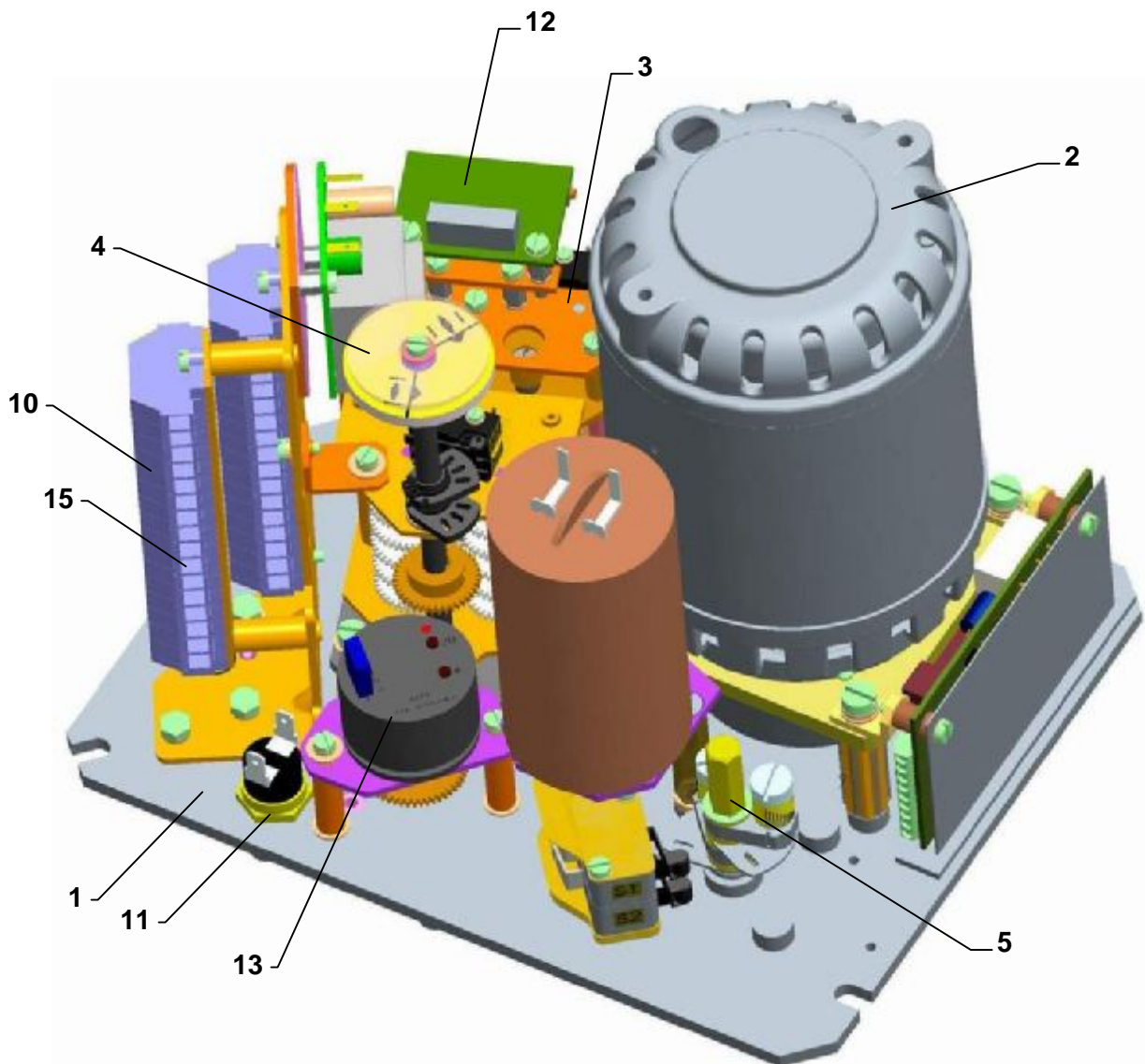

Fig.1

2.2 Specifications

Basic Specifications are given in the table 1.

Table 1: Basic Specifications

Type/ type number	Operation speed ±10[%]	Number of revolutions	Maximum load torque	Switching torque ±10 [%]	Weight	Electric motor ¹⁾					
						Supply voltage		Nominal			Capacitor capacity
								Power output	Speed	Current	
	[rev/min]	[rev]	[Nm]	[Nm]	[kg]		[V]	[W]	[1/min]	[A]	[µF/V]
1	2	3	5	6	7	8	9	10	11	12	13
SO 2 Type Nr.062	40	1,5 až 330	8	5-10	12,0 – 18,5	Single-phase	230/220	60	2750	0,7	7/400
	40		10	7,5-12							
	20		22	15-25							
	12,5		34	24-40							
	10		42	30-50							
	20		34	24-40				120	2 600	1	8
	12,5		50	36-60							
	10		68	48-80							
	20		38	30-45							
	12,5		61	48-72							
	10		76	60-90		Three-phase	3x400/ 3x380	90	2750	0,35	-
	40		8	5-10							
	40		10	7,5-12							
	40		17	12-20							
	20		34	24-40							
	12,5		51	36-60				180	2650	0,6	-
	10		68	48-80							
	20		50	36-60							
	12,5		68	48-80							
	10		85	60-100							
	40		10	7,5-12		Single-phase/ direct current-voltage	24 AC/DC	65	2800	5,00	-
	20		21	15-25							
	12,5		34	24-40							
	10		42	30-50							
	20		38	35-45				120	2800	9,00	-
	12,5		61	48-72							
	10		76	60-90							

1) Switching elements for different type of load (also for EA) defines standard EN/IEC 60 947-4-1.

Other specifications:

EA protection enclosure: IP 67, IP 68 ((EN (IEC) 60 529))

According to definition for EA, enclosure IP68 fulfills following requirements:

-water column max. 10m

-time of continuous submersion in water max. 96 hours.

Mechanical ruggedness:

sinusoid vibrations with frequency of 10 to 150 Hz with shift amplitude of 0,15 mm for $f < f_p$

.....with acceleration amplitude of $19,6 \text{ m/s}^2$ for $f > f_p$

..... (transition frequency f_p should be in range 57 to 62 Hz)

Resistance by drops.....300 drops with acceleration of 5 m.s^{-2}

Self-locking: the EA is self-locked

Protection of the motor by the thermal switch
Brakes of the EA: electro-magnetic brakes
Clearance of the output part: max.5° at 5% load of the switching-off torque

Electric control:

- remote control (the output element of the EA is controlled with supply voltage)

Adjustment of the limit positions

Precision of limit position switches adjustment working angle $\pm 90^\circ$
 Additional position relays adjustment cca 1 revolution beneath the limit switches
 Tandem position switch operating angle $\pm 90^\circ$
 Hysteresis of position switches
 max. 180°
 Hysteresis signaling switches (S5,S6) max. 5% of the max. stroke of the chosen range

Failure of the customer to specify the particular operating speed parameter in more details the speed are set to the value according to the 6th degree of the selected range – see Table 3.

Adjustment of the torque switches:

If other adjustment not specified the switching torque is set to the maximum value with tolerance of $\pm 10\%$.

Switches – standard version D38:

supply voltage 250 V(AC); 50/60 Hz; 6(4) A; $\cos \varphi=0,6$, resp.: 24 V (DC); T=L/R=3ms
 min. current 100mA

Position switches and signaling switches:.....switches DB 6 (Cherry)

supply voltage 250 V(AC); 50/60 Hz; 2 A; resp.: 250 V (DC); 0,1 A

Space heaters (E1)

The space heater – supply voltage:.... according to the supply voltage of the motor (max. 250 V AC);
 Heating power: cca 20 W/55°C

Thermal switches of the space heaters (F2)

Supply voltage: according to the supply voltage of the motor (max. 250 V AC, 5 A)
 Temperature of switching on: $+20^\circ\text{C} \pm 3\text{ K}$
 Temperature of switching off: $+30^\circ\text{C} \pm 4\text{ K}$

Manual control:

- with a handwheel after pressing the detent button. Rotate the handwheel clockwise to move the output shaft in the direction „Z“.

Electric control:

- remote control (the output element of the EA is controlled with supply voltage)

Resistive position transmitter RP 19:

Resistance (single **B1**) 100; 2 000 Ω
 (double **B2**) 2x100 Ω , 2x2000 Ω
 Operating life of transmitter $1 \cdot 10^6$ cycles
 Load capacity 0,5 W do 40 °C, (0 W/125°C)
 Nominal current of sliding contact max.35 mA
 Maximum supply voltage..... $\sqrt{P \times R}$ V DC/AC
 Potentiometer linearity error..... $\pm 2,5 [\%]^1$
 Potentiometer hysteresis max. 5 $[\%]^1$
 Potentiometer values at limit positions:..... “O” (open)..... $\geq 93\%$, ”Z“ (closed)..... $\leq 5\%$

Capacitive (B3a): non-contact, life 10^8 cycles

2-wire connection with built-in power supply or without built-in power supply

The current signal $4 \div 20$ mA (DC) is acquired from the capacitive transmitter supplied from the internal or an external voltage supply source. The electronics of the transmitter is protected against eventual wrong polarity and current overloading. The entire transmitter is galvanic insulated so several transmitters can be connected to one external voltage source.

Power supply voltage (with power supply)	24 V DC
Power supply voltage (without power supply)	18 to 28 V DC
Ripple voltage	max. 5%
Max power input	0,6 W
Load resistance	0 to 500 Ω
Load resistance can be single side grounded.	
Influence of resistance on output current	0,02%/100 Ω
Influence of voltage on output current	0,02%/1V
Temperature dependency	0.5% / 10 $^{\circ}$ C
Output signal values at limit positions:	
"O"	20 mA (terminals 81; 82)
"Z"	4 mA (terminals 81; 82)
Values tolerance of output signal of EPV	
"Z"	+0,2 mA
"O"	$\pm 0,1$ mA
Linearity deviation:	± 2.5 % ¹⁾
Hysteresis	max. 2.5 % ¹⁾

DCPT3M – current transmitter (B3b)

- 2-wire connection without built-in power supply or with built-in power supply

Current signal	$4 \div 20$ mA (DC) with optional mirroring ($20 \div 4$ mA)
Mode of operation	contactless, magnetic resistance
Transmitter increments without gears	0,0879 $^{\circ}$
Loading resistor:	max. 500 Ω
Operating stroke	35 to 100% of the rated stroke at the gear ratio
Non-linearity	max. ± 1 %
Non-linearity - geared	max. ± 2.5 %
Power supply voltage for version without power source	15 through 30 V DC
Power supply voltage for version with built-in power source	24 V DC
Operating temperature	-40 to +80 $^{\circ}$ C
Values tolerance of output signal of EPV	"Z" +0,2 mA
.....	"O" $\pm 0,1$ mA
Linearity deviation:	± 2.5 % ¹⁾
Hysteresis	max. 2.5 % ¹⁾
Error messages	by flashing LED

Electronic positional transmitter (EPV) - converter R/I (B3)

2-wire version, resp. 3-wire (without built-in power supply, or with built-in power supply)

- Output signal for 2-wire version $4 \div 20$ mA (DC)
- Output signal for 3-wire version $0 \div 5$ mA (DC)
- $0 \div 20$ mA (DC)
- $4 \div 20$ mA (DC)
- $0 \div 10$ V (DC)

Power supply voltage for 2-wire version without built-in power supply	15 to 30 V DC
Power supply voltage for 2-wire version -with built-in power supply	24 V DC $\pm 1,5$ %
Load resistance for 2-wire version	max. $R_L = (U_n - 9V) / 0,02A$ [Ω]
• (U_n – voltage [V])	
Power supply voltage (at version without built-in power supply)	24 V DC $\pm 1,5$ %
Load resistance for 3-wire version 0-5mA	max. 3 k Ω

Load resistance for 3-wire version 0/4-20mA	max. 750 Ω
Load resistance for 3-wire version 0-10 V	max. 10 k Ω
Temperature dependency.....	max. 0,020 mA / 10 $^{\circ}\text{C}$
Output signal values at limit positions on the terminal 81,82.....	„O“.... 20 mA (5 mA, 10 V)
.....	„Z“.... 0 mA (4 mA, 0 V)
Values tolerance of output signal.....	„Z“ +1,5 % ¹⁾
.....	„O“ \pm 1,5 % ¹⁾
Linearity deviation.....	\pm 2,5 % ¹⁾
Hysteresis.....	max. 2,5 % ¹⁾

1) from rated value of transmitter referred to output values

2.2.1 Mechanical connection:

- with flanges (ISO 5210, DIN 338, GOST R 55510, non-standard)
Main and connecting dimensions are given in the dimensional drawings.

2.2.2 Electric connection

- **with terminal board (X):** max. 32 terminals - connecting cable size max. 2.5 mm²;
2 cable glands – M20x1,5 (\varnothing D = 8 to 14,5mm)
- **with connector (XC):** max. 32 terminals - connecting cable size max. 0.5 mm²
2 cable glands – M20x1,5 (\varnothing D=8 to 14,5 mm);
 \varnothing D = connecting cable diameter

With protection terminal: external and internal, mutually connected and marked with protection earthing mark

Electric control: Main and connecting dimensions are given in the **dimensional drawings**.

There must be power switch or motor circuit breaker included to the power supply which must be placed as close as possible to the device, easily accessible to the operator and marked as an disconnecting device of actuator.

3. Installation and Dismantling of the Actuator



Follow safety regulations!

Note:

Check again whether the EA is place in accordance with the Chapter “Operation Conditions”. If the installation conditions are different than recommended it is needed to consult the situation with the producer.

Before starting the installation onto the valve:

- Check again whether the EA was not damaged while storing.
- Check compliance of the stroke adjusted by the producer and the connecting dimensions of the EA with the parameters of the valve.
- In case of any difference perform the adjustment according to the Chapter “Adjustment”.

3.1 Installation

The EA are adjusted by the producer to the parameters stated on the nameplate.
Put on the handwheel before assembly.

3.1.1 Mechanical Connection for Flanged Version

- Defat the abutting areas of the connecting flange of the EA valve or the gear carefully;
- Lubricate the output shaft of the valve/gear with a grease not containing any acids;

- Set the EA to the limit position “closed”, set the valve to the same position;
- Put the EA onto the valve with the output shaft reliably stalled in the valve coupling/gear;
- **Attention! Do not adjust EA on an armature forcibly because of damage of the gear!**
- Use the hand wheel to turn the EA to fit the openings in the EA and valve flanges if needed;
- Check whether the connecting flange abuts with the valve/gear.
- Fix the flange with four screws (with mechanical strength min 8G) fixed the way the actuator can be moved. Tighten the screws equally in cross.
- At the end check the correctness of the fixture with the valve with rotating the hand wheel.

3.1.2 Electric Connection with Mains or Checking of Functions

Follow up with connecting the EA with mains or master system.



1. *Follow instructions given in the Chapter “Requirements for Professional Qualification...” !*
2. *While laying electrical line abide by the instructions for heavy current installations. Power supply cables must be of the type approved. Minimum thermal resistance of power supply cables and wires must be +90°C.*
3. *Cables should be brought to terminal boards or connectors with cable screwed cable glands !*
4. *Before the EA is put into operation join the internal and external earthing terminals!*
5. *The inlet cables should be fixed onto a fixed construction max. 150 mm from the cable glands !*
6. For proper EA functioning the torque (S1, S2) and position (S3, S4) limit switches must be serial connected into the electric motor control circuit – see the recommended connection for single phase electric motor (example connection 1) and for 3 - phase electric motor (example connection 2).
7. The output wires electric motor thermal protection must be connected into the electric motor control circuit on a such way that when the electric motor thermal protection opens (it means when the allowed electric motor winding temperature is exceeded) it will cause the disconnection of the electric motor supply voltage.
8. To prevent moisture from entering the actuator around the connecting cables, the cables must be sealed with silicone material at the point of penetration through device shell.

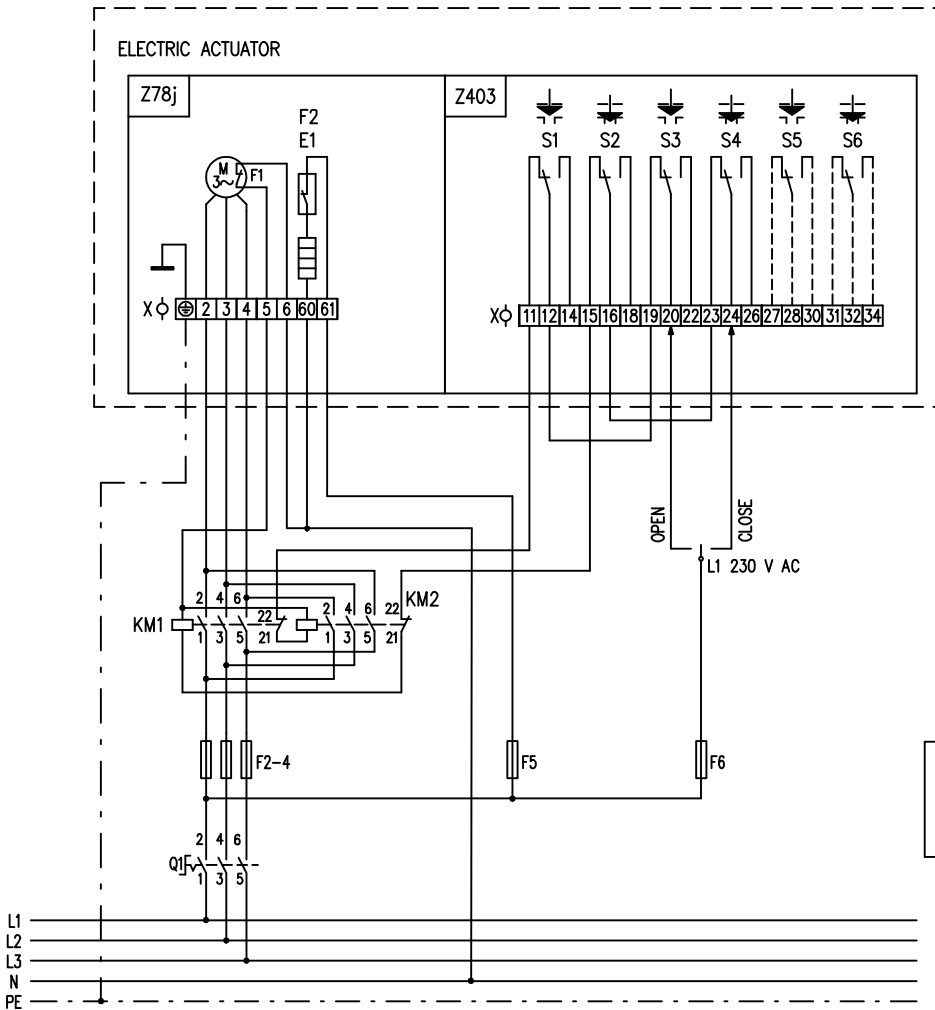

Example connection 1
ES with 3-phase electric motor

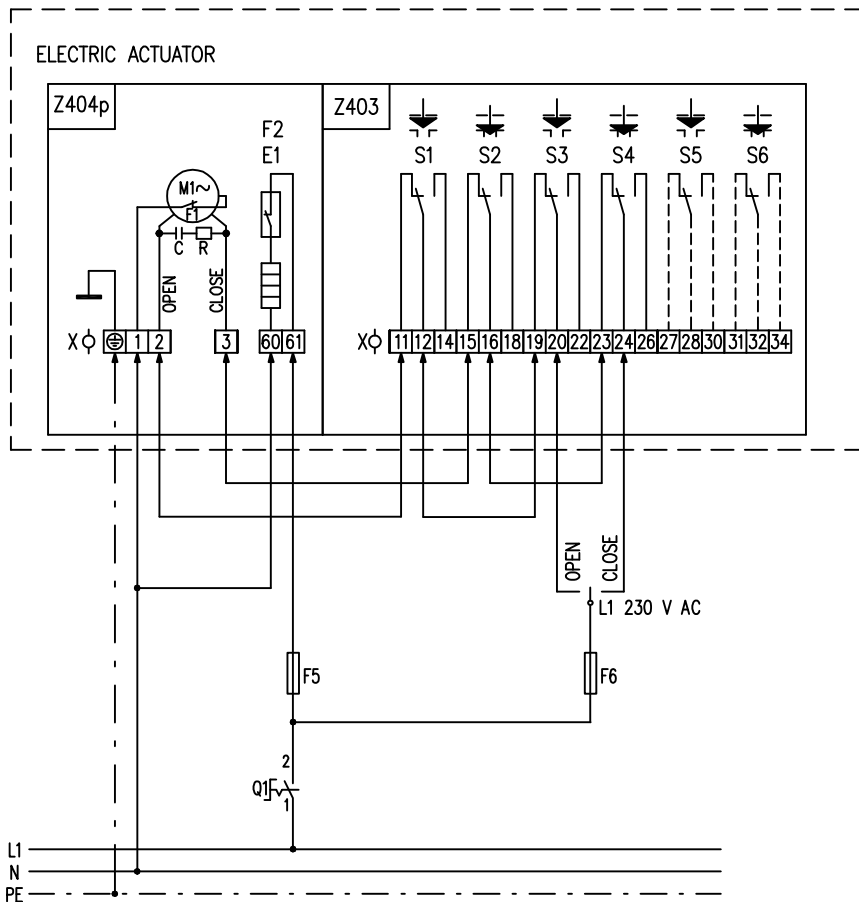

Example connection 2
ES with single - phase electric motor

Connection with the terminal board:

Before the connection remove the actuator case and check whether the type of current, power supply and frequency correspond with the data on the actuator nameplate.

Electric connection:

- The electric connection should be realized according to the wiring diagram stuck into the case of the EA;
- The electric connection should be performed through two cable glands see No. 2.2.1;
- Once electrical services are completed put on the cover and fasten it evenly crosswise by bolts. Fasten the cable outlets to ensure specified shielding.

Electric connection to connector:

- Check whether the type of current, power supply and frequency correspond with the data on the actuator nameplate;
- Loosen the connector bodies;
- Bare ends of cables;
- Use the recommended tongs* to connect the connector sockets onto the cable ends;
- Fix the connectors and tighten;
- Tighten the cable leads to assure the protection enclosure.

Notes:

1. *The EA are delivered with cable glands which in case of correct tighten are onto the supply lead allow the protection enclosure of IP 68. To arrange the enclosure it is needed to use seal rings according to the actual size of cable and the required temperature.*
2. *The cable is to be fixed the way corresponding with its allowable bending radius not to damage or deform the sealing element of the cable lead. The supply leads have to be fixed onto a fixed construction max. 150 mm from the leads.*
3. *It is recommended to connect the remote transmitters with shielded wires.*
4. *The face areas of the control part cover should be clean before fixing it back.*
5. *The EA is reversible if the time interval between the power supply is switched off and on for the reverse direction of the output part motion is at least 50 ms.*
6. *The allowed delay after it is switched off, i.e. time from the switches reaction up to the motor without any voltage is 20 ms maximally.*



Follow instruction of producers of valves, whether switching off in the limit positions should be arranged by the position or torque switches!

After the EA is electrically connected it is advised **to check functions:**

- After the EA is electrically connected to check the correct functions of the position and the torque switches S1 - S6 and if needed adapt the order of the single phase leads for the 3-phase electric motor.
- Set the valve manually into an mid-position.
- Connect the power supply to the terminal D2 for supplying the EA in the direction "opening" and follow the direction of the position indicator rotation in the control part of the EA . When EA is connected correctly, the position indicator of EA, looking from above, must rotate in the direction of symbols „open“ or „closed“ and at the same time the output component of EA must move to the direction „opens“. If not it is necessary to change the phase leads L1 and L3 on the terminals 2 and 4 mutually. After the exchange is made check the direction of the EA rotation.
- If any of the functions is not correct, check the switches whether they are wired properly according to the wiring diagrams.

3.2 Dismantling



**Before dismantling it is needed to disconnect power supply of the EA!
Do not connect and disconnect the EA when live not to cause any injury by electrical current!**

- Switch the EA off the mains.
- Disconnect the leads from the terminal board of the EA and loosen the cable from the plugs.
- Loosen the fixing screws of the flange and screws of the EA coupling and split the EA and the valve.
- If sending the EA to repair put it into a package steady enough not to allow its damaging.

4. Adjustment



Attention! See chapter 1.2

If it is necessary to connect the supply voltage to Electric actuator, make sure by following the mentioned procedure that there is no injury caused by the electric current. Otherwise, disconnect the Electric actuator from the electricity network. **Observe safety regulations!**

After mechanical connection, electrical connection and checking of connection and function start setting and adjustment of the device. The adjustment can be performed at a mechanically and electrically connected EA. This part describes adjustment of EA to specified parameters in case that any unit of EA is reset. Laying of adjusters of the control board is shown on Fig.1

4.1 Adjustment of the Torque Unit

The switching - off torques are adjusted by the producer for both directions, i.e. for the direction "opening" (the torque switch S1) as well as for the direction "closing" (the torque switch S2) to the specified value with tolerance of $\pm 10\%$. If not stated else they are adjusted to the maximum rate.

Adjustment and changing of settings of the torque unit to other torque values is possible using the adjusters according to Fig. 2. The switching - off torque can be only reduced with turning the adjusting screws with the scale against the adjustment lines on the torque unit arm. Setting to the longest line means that the switching - off torque is set to the maximum value. Setting to the lower line means reducing of the switching - off torque.



REGULATING
SCREW OF
TORQUE
SWITCH S2

REGULATING
SCREW OF
TORQUE
SWITCH S1

Fig.2

4.2 Adjustment of position-signalling unit (S3(S13),S4(S14)) (Fig.3)

EA is delivered set to a stroke corresponding to 6th according to table 3 or to a stroke required by customer. The procedure for position switches setting, adjustment a new setting is as follows (Fig. 6, 7):

Having the set screw of the gear unit wheel released, move the adjustable wheel to a required stage of the range (it means to a one corresponding accurately to the particular revolutions, or to the next higher one) according to table 3 and Fig.7. When moving the adjustable wheel, take care to achieve the proper meshing with the gear wheel of the subjected stage, and then tighten the set screw back.

Move EA to the "open" position electrically or manually. If, with electric move, EA has been switched off by S3 switch (Fig. 6), insert a screwdriver into set screw (29), press it and rotate in the arrow direction until an appropriate cam opens S3 switch. Pull the screwdriver out (see notice 1) and continue in moving EA in the „open“ position.

In the „open“ position, insert a screwdriver into set screw (29), press it and rotate in the arrow direction until an appropriate cam closes S3 switch. Pull the screwdriver out (see notice 1).

Move EA to the "close" position electrically or manually. If, with electric move, EA has been switched off by S4 switch (Fig. 6), insert a screwdriver into set screw (28), press it and rotate in the arrow direction until an appropriate cam opens S4 switch. Pull the screwdriver out (see notice 1) and continue in moving EA in the „close“ position.

In the „close“ position, insert a screwdriver into set screw (28), press it and rotate in the arrow direction until an appropriate cam closes S4 switch. Pull the screwdriver out (see notice 1).

Having position switches adjusted, You may need (depends on EA accessories) to adjust signaling switches and position indicator.

Notice 1: in the case that the set screw remains pressed notwithstanding the screwdriver is out (it means that disengaged gear wheels don't mesh each other), turn gently the set screw against the arrow direction without pressing it until the set screw releases back to its initial position.

In the variant of the EA equipped with the S13, S14 tandem position switches, these switches are to be adjusted after having the setup of the S3 a S4 switches completed, it means the S3 switch must switch simultaneously with the S13 switch, and the S4 switch must switch simultaneously with the S14 switch.

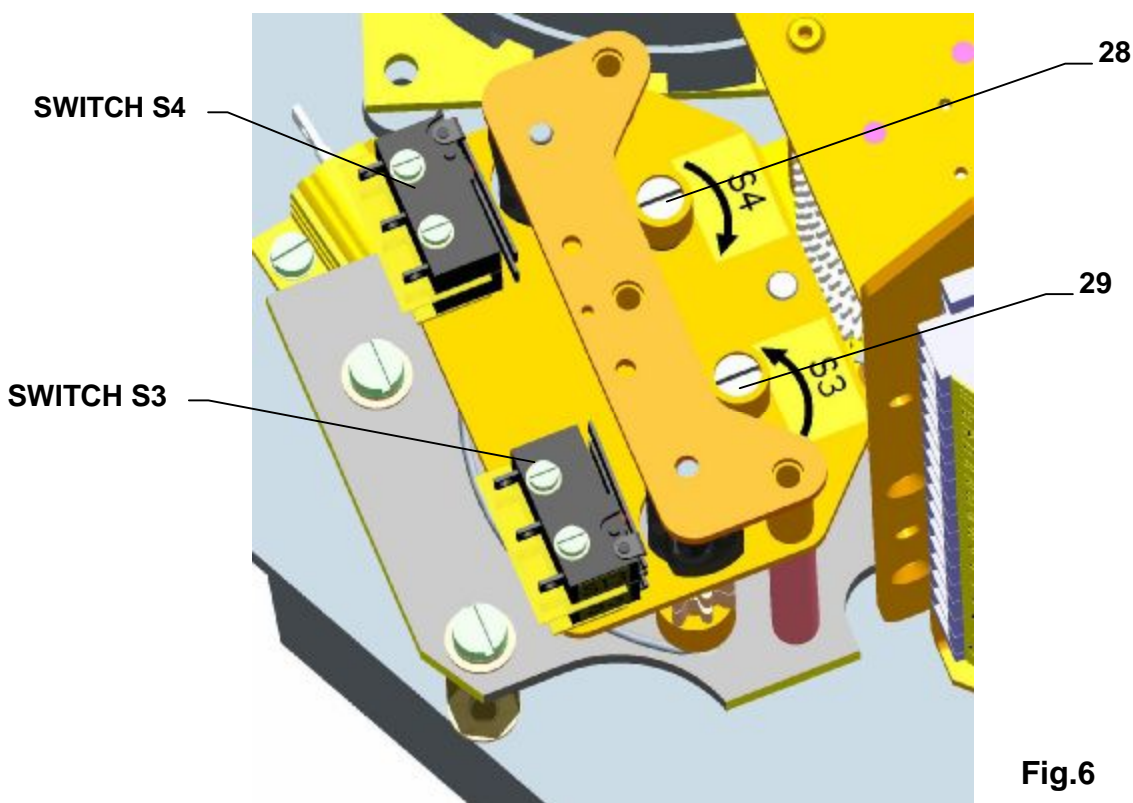
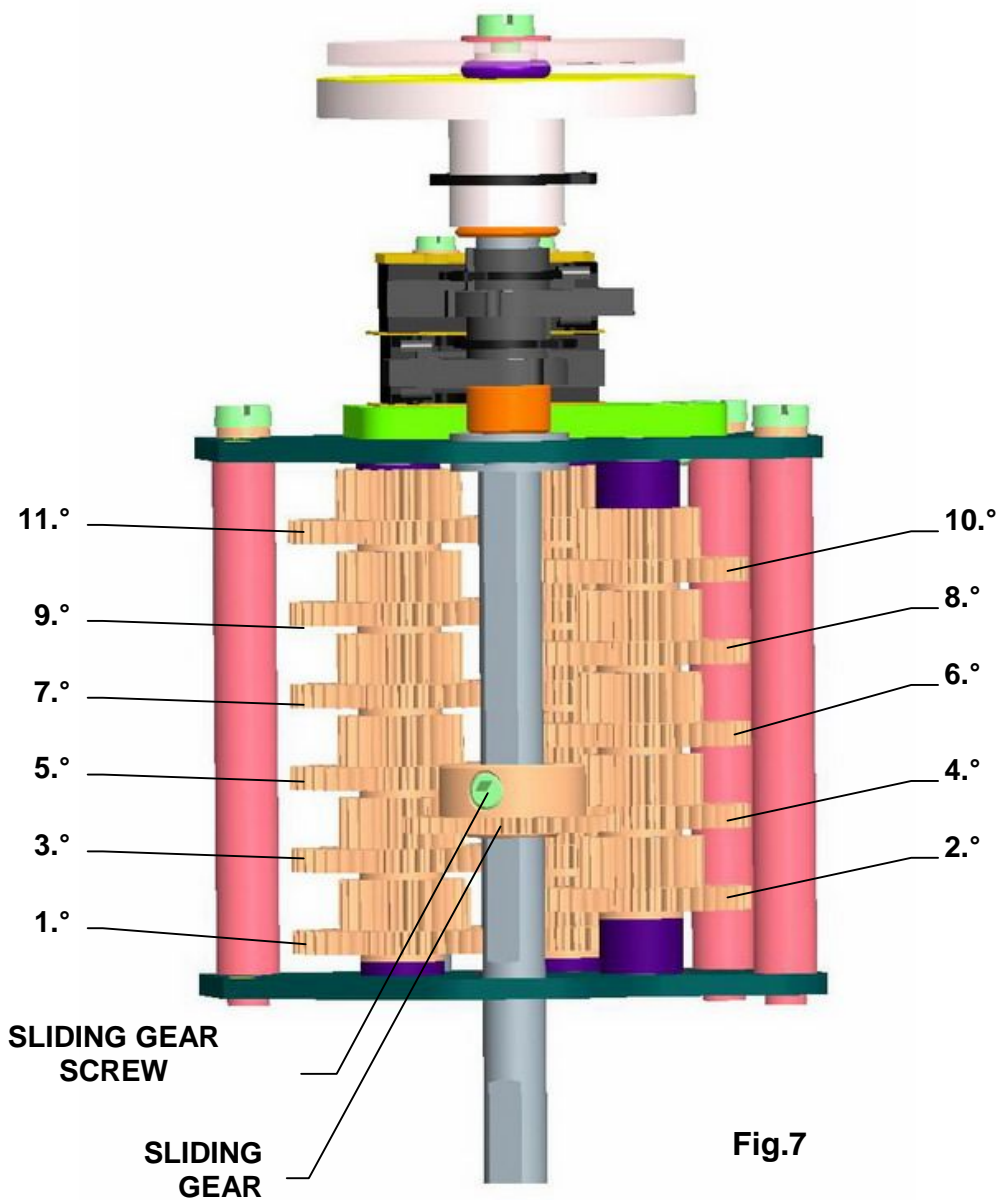

Fig.6

TABLE 3	
STROKE STAGE	MAX. OPERATING SPEED EA (if the customer doesn't specify a producer, EA will be set up to the 6.degree of stroke)
	SO 2
1 st	-
2 nd	1,5
3 rd	2,8
4 th	5
5 th	9
6th	16
7 th	30
8 th	55
9 th	100
10 th	180
11 th	330



4.3 Signaling switches adjustment (S5,S6) (Fig. 8)

The signaling switches of EA are at producer preset to switch on about 10% before end positions provided the customer not specified otherwise. Before proceeding with signaling switches adjustment, S3, S4 end position switches must be adjusted according to the previous chapter if necessary. The procedure of signaling switches adjustment is as follows:

- Check that the adjusting wheel of the signalling gearbox is adjusted to the required level of the stroke scope.
- Bring EA to a position in which You want S5 switch to close when EA is running in the „open“ direction.
- Turn cam (31) of S5 switch (27) clockwise until S5 switch closes.
- Bring EA to a position in which You want S6 switch to close when EA is running in the "close" direction.
- Turn cam (30) of S6 switch (26) counterclockwise until S6 switch closes.

Notice: This signaling is capable to signalise from 50 up to 100 %..of the working stroke in both movement directions. With switch reversing function, a signaling capability from 0 up to 100 % is available.

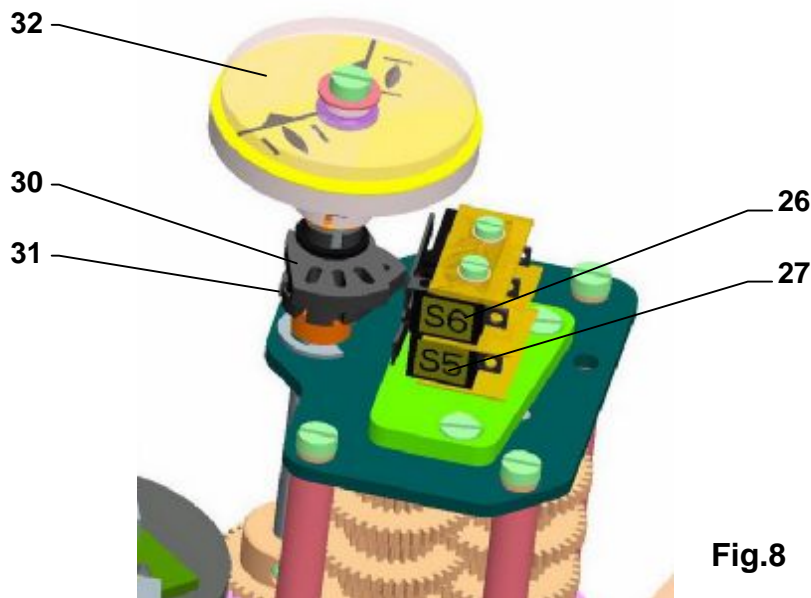

Fig.8

4.4 Position indicator adjustment (Fig.8)

The position of the output member relative to the end positions of EA stroke is indicated by a mechanical position indicator.

- Before starting to adjust the position indicator, S3 and S4 position switches must be adjusted if required.
- The procedure of position indicator adjustment is as follows :
- Bring EA to the „closed“ position.
- Turn the position indicator disc (32) to bring a mark identified with a symbol for the „close“ direction in coincidence with a mark on the upper cover aperture (If it is difficult to turn the wheel, release the screw using the screwdriver to fix the wheel).
- Bring EA to the „opened“ position.
- Turn the upper part of the position indicator disc (32) to bring a mark identified with a symbol for the „open“ direction in coincidence with the mark on the upper cover aperture.

4.5 Adjustment of resistant transmitter (Fig.4)

Function of resistance transmitter:

- remote position indicator
- remote position indicator with converter.

Before the resistant transmitter adjustment the position switches have to be adjusted. Adjustment consists in setting of the resistance in the defined limit position of the EA.

Notes:

1. In case that the EA is not used in the working revolutions range according to chosen degree on the competent stroke according to table Nr.3, the resistance in the limit position "open" is proportionally reduced.
2. With EA of 2- wire converter a transmitter of 100 W resistance is used .

To adjust the transmitter follow these steps:

Loosen the fixing screws (9) of the transmitter holder and push the transmitter out of mesh.

Put the actuator to the position "closed" (with the hand wheel, or with the local electric position control until the corresponding position switch S2 or S4 switches).

Connect the measuring instrument for measuring the resistance to terminals 71 and 73 on the Electric actuator. Rotate the transmitter (91) shaft until resistance of $\leq 5\%$ of the nominal transmitter resistance.

In the position put the transmitter to mesh with the drive wheel and fix the fixing screws on the transmitter holder. Disconnect the meter from the terminal board.

If when in the open position, the value of the resistance of the transmitter is greater than permitted, then the working stroke must be reduced.

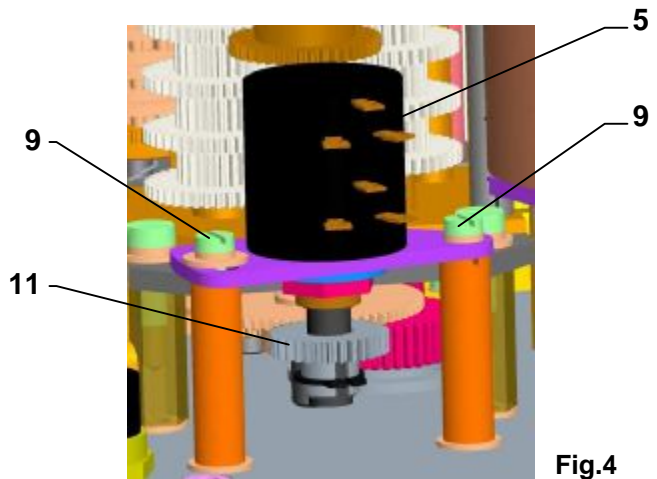

Fig.4

4.6 Adjustment of the Electronic Position Transmitter (EPV) - the Resistive Transmitter (Potentiometer) with the Converter PTK 1

EPV – the 2-wire version (Fig. 5,5a)

The position transmitter with the converter PTK1 is in the plant adjusted to have the output current signal on the terminals 81-82 as follows:

- in the position "open" 20 mA
- in the position "closed" 4 mA

If the transmitter requires a new adjustment follow these steps:

Adjustment of the EPV – 2 wire version

- Put the actuator to the position "closed" and switch the power supply off.
- Adjust the resistive transmitter according to the previous chapter. The resistance is to be metered on the terminals X-Y, resp. R-R (Fig. 5,5a). The used transmitter resistance is 100 Ω.
- Switch the converter's power supply on.
- Turn the adjusting trimmer **ZERO**, resp. **A** to adjust the output current signal rate measured on the terminals 81-82 to 4 mA.
- Set the actuator to the position "open".
- Turn the adjusting trimmer **GAIN**, resp. **B** to adjust the output current signal rate measured on the terminals 81-82 to **20mA**.
- Check the output signal of the converter in the both limit positions, and repeat the procedure if needed.

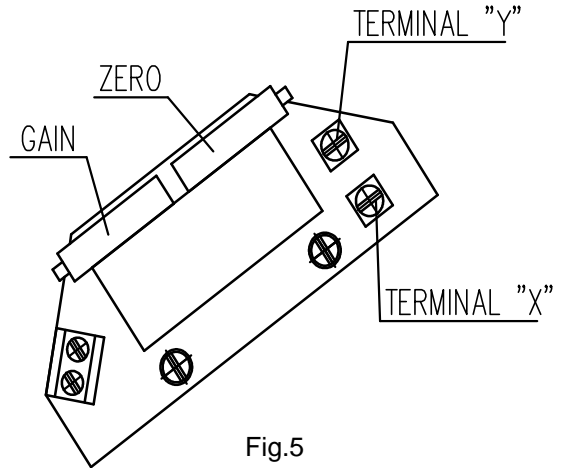

Fig.5

Note:

The output signal of 4-20mA can be adjusted at the range from 75 up to 100% of the rated stroke stated on the actuator's nameplate. At values less than 75% the value 20mA is reduced proportionally.

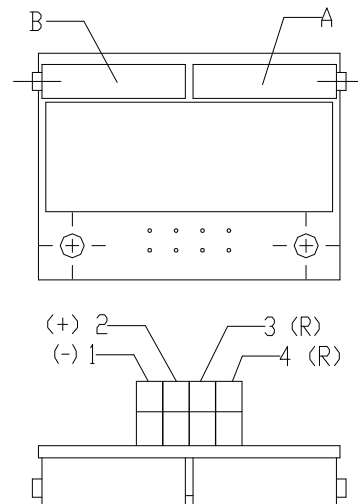

Fig. 5a

EPV – 3-wire version (Fig. 6, 6a)

The resistive transmitter with the converter is in the plant adjusted to have the output current signal metered on the terminals 81-82 as follows:

- in the position "open".....20 mA resp. 5 mA resp. 10 V
- in the position "closed".....0 mA resp. 4 mA resp. 0 V

according to the specified version of the converter.

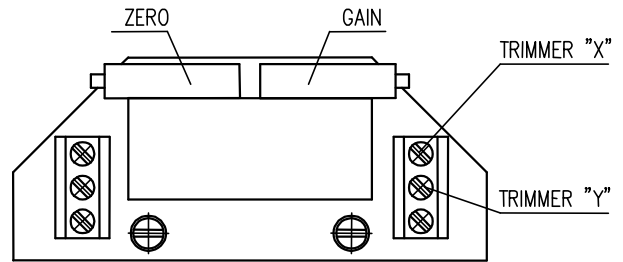

Fig. 6

If the transmitter requires a new adjustment follow these steps:

- Put the actuator to the position "closed" and switch the power supply off.
- Adjust the resistive transmitter according to the previous chapter. The resistance is to be metered on the terminals **X-Y**, resp. **0%-100%** (Fig. 6, 6a). The used transmitter resistance is **2000 W** or **100 W**.
- Switch the converter's power supply on.
- Turn the adjusting trimmer **ZERO**, resp. **A** to adjust the output current signal rate measured on the terminals 81-82 to 0mA resp.4 mA, resp. 0 V.
- Set the actuator to the position "open".
- Turn the adjusting trimmer **GAIN**, resp. **B** to adjust the output current signal rate measured on the terminals 81-82 to 20mA, resp. 5 mA, resp. 10V.
- Check the output signal of the converter in the both limit positions, and repeat the procedure if needed.

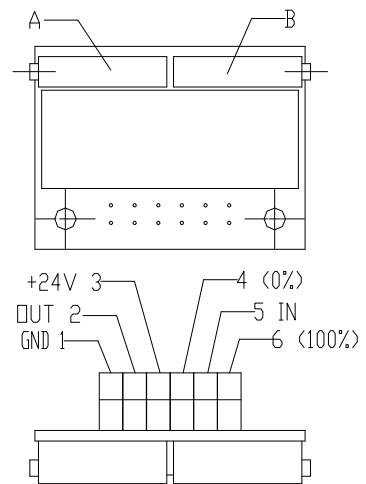

Fig .6a

Note:

The output signal of (0-20mA, 4-20mA or 0-5mA - according to the specification) can be adjusted at the range from 85 up to 100% of the rated stroke stated on the actuator's nameplate. At values less than 85% the value of the output signal is reduced proportionally.

4.7 Adjustment of the DCPT3M transmitter

Before the transmitter **DCPT3M (Fig.7)** adjustment the position switches S3 and S4 have to be adjusted. Adjustment consists in setting of the output signal value in the limit positions of the actuator.

By default (unless determined otherwise by the customer), the manufacturer aligns the DCPT3M transmitter so that output signal value 4mA is set for the limit position "closed" and 20 mA for the position "opened". By default the characteristics of the output signal is set to 20-4 mA (ascending).

Notes 1: -this type of transmitter enables the assignment 4 mA / 20 mA of the output signal value to any limit position of the actuator.

2:-the transmitter is adjustable within the range of 35 to 100% of the full stroke specified in the nameplate. By wrong stroke adjusting (outside transmitter range), error appears (LED blinking 2-times)

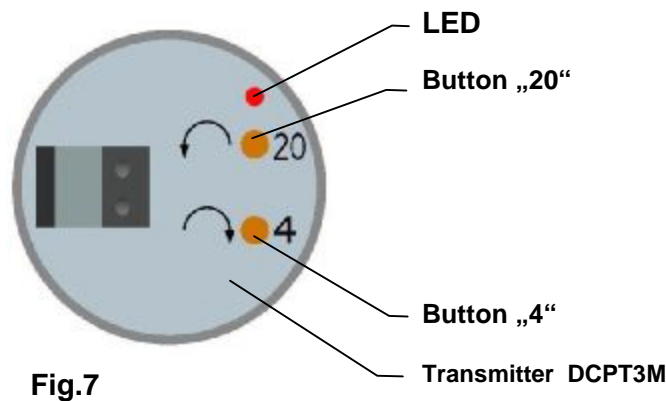

Fig.7

Setting of limit positions

If limit positions require re-adjustment, proceed as follows:

Adjustment of the "4 mA" position:

- Turn on the power supply voltage to DCPT3M
- Reset the actuator to the limit position that you want to assign 4 mA signal value to and press (for about 2 seconds) the pushbutton "4", until LED flashes

Adjustment of the "20 mA" position:

- Turn on the power supply voltage to DCPT3M
- Reset the actuator to the limit position that you want to assign 20 mA signal value to and press (for about 2 seconds) the pushbutton "20", until LED flashes

Notes 3: Transmitter error code may result when the first limit position is saved (2x LED flash). The error code is erased by saving of the second limit position, provided that the saved limit positions are within 35 to 100% of the rated stroke specified in the nameplate.

If necessary, please change the characteristic of the output signal from descending to ascending or vice versa, according to the following chapter.

Setting of the ascending/descending characteristic of the output signal

When the characteristic of the transmitter output signal is changed, the set limit positions "4 mA" and "20 mA" are maintained, however the operating range (stroke of DCPT3M) between these two positions is changed to the complement of the original operating range.

When the DCPT3M transmitter is set so that output signal value 4mA is set for the limit position "closed" and 20 mA for the position "opened", the characteristic must be set to ascending (Adjusted by producer if customer define others).

When the DCPT3M transmitter is set so that output signal value 20 mA is set for the limit position "closed" and 4 mA for the position "opened", the characteristic must be set to descending.

If you need to toggle the characteristic of the transmitter output signal 4-20 mA (ascending), or 20-4 mA (descending), please proceed as follows:

- Turn on the power supply voltage to DCPT3M
- For 4-20 mA (ascending characteristic) press the pushbutton "20" and subsequently "4" and hold both buttons pressed until LED flashes.
- For 20-4 mA (descending characteristic) press the pushbutton "4" and subsequently "20" and hold both buttons pressed until LED flashes.

Calibration MENU

- For current value increasing push and hold the button „20“ until current increase. Longer holding The calibration menu enables setting of default parameters and calibration of current values 4 and 20 mA (fine tuning of the value of the output current signals 4 and 20 mA in the limit positions).

Calibration mode input for adjusting of output current:

- Turn off the power supply to the transmitter power supply source.
- Press and hold the "4" and "20" adjustment pushbuttons.
- Turn on the power supply to the transmitter power supply source.
- Hold both pushbuttons until the first and on to the second flash of LED.
- In this menu input is firstly adjusted for value 4 mA.

Current 4-20 mA adjusting in calibration mode:

- For current value decreasing push and hold the button „4“ until current decrease. Longer holding of this button means autorepeat of current value. Releasing of this button means writing current value. of this button means autorepeat of current value. Releasing of this button means writing current value.

Toggling between 4 and 20 mA in the calibration mode:

- For 4 mA press the pushbutton "20" and subsequently "4" and hold both buttons pressed until LED flashes.
- For 20 mA press the pushbutton "4" and subsequently "20" and hold both buttons pressed until LED flashes.

Restoring factory (default) settings:

Warning: Using this all adjusted parameters will be canceled and adjusted to factory settings (current calibration, positions 4 and 20 mA). Therefore it is necessary to make new transmitter calibration.

- Turn off the power supply to the transmitter power supply source.
- Press and hold the "4" and "20" adjustment pushbuttons.
- Turn on the power supply to the transmitter power supply source.
- Hold both buttons until first and second LED blink.
- Turn-off and turn-on transmitter power supply again.
- LED stays lighting and after 10 sec. go out.

Leaving calibration mode:

- After 10 sec. not working in calibration mode, LED will go out as a signal of leaving calibration mode. If LED is blining, error appears.

Transmitter errors:

In case of error LED starts blinking. Number of LED blinking means number of error in table No. 4. After longer pause blinking process repeats. In case of more errors, number of errors are blinking one after another. Longer pause between blinking separate particular errors.

Example of error number 2 and 1 according to LED blinking:



TABLE 4		
Number of blinking LED	Error	Eliminate the error
1x	Transmitter position outside operating range	<ul style="list-style-type: none"> - change the characteristics of the output signal, respectively. - return the actuator output member to the working area, resp. - sort the end positions of the transmitter
2x	Incorrectly set working stroke	<ul style="list-style-type: none"> - check the stroke adjustment range and reset the transmitter stroke.
3x	Sensor error	<ul style="list-style-type: none"> - change transmitter.
4x	Incorrect parameters in EEPROM	<ul style="list-style-type: none"> - change transmitter.

5. Service and Maintenance

5.1 Service



1. In general it is supposed that the EA is serviced by a qualified person as required in the Chapter 1!
2. After the EA is put into operation it is necessary to check whether during manipulation its surface finishing was not damaged – the damages should be eliminated to prevent the surface against deterioration caused by corrosion!

- The EA requires just an insignificant service. The reliable operation is determined by the correct putting into operation.
- The service of the EA results from the operation conditions and generally consists in treating the information for subsequent performing of a required function. The EA can be controlled by remote control electrically or manually on the place of their installation. The manual control is available with a hand wheel.
- The service staff should arrange the required maintenance and prevent the actuator during operation against impacts of environment and climate what exceed the frame of allowed influences stated in the Chapter “Operation Conditions”.
- It is necessary to avoid overheating of the EA surface, exceeding of parameters stated on the nameplate and abnormal vibrations of the EA.

Manual control:

- If the manual control is needed (adjustment, function checking, failures etc.) the staff can reset the regulated member using the handwheel. While rotating the handwheel clockwise the output element moves in the direction “CLOSING”.
- If the Electric actuator is fitted with an arresting button, then during the manual control the arresting button must be pressed, Fig. 11. After termination of manual control, release the arresting button.

Electric local control: - additional equipment (Fig.8)

If necessary in the case of accession, function check and so on, it is possible to preset EA or change some parameters by local electric control with secured power feeding.

It is possible to control after removing of the padlock (1). Control mode selection is changed by sequential pressing of the button (2) **REMOTE-OFF-LOCAL** to “Remote” “Shut off”, “Local”, “Shut off”, which is displayed on 2 rows LCD (6). Signalling motion and failure of the EA is also indicated by LEDs diode (7).

Mode “Shut off” – it is possible to change some parameters in this mode in particular menus.

Mode “Local” – it is possible to control EA by the local buttons in this mode - (3) **OPEN**, (5) **STOP**, (4) **CLOSE**.

Mode “REMOTE” – it is possible to control EA by the commands from superior remote system

Proceeding in setup of particular parameters in the mode “SHUT OFF” is described in the independent amendment No. 74 1076 02, which is delivered together with EA equipped by local electric control.

When you finish the work in the “REMOTE” mode put the padlock on the button (2) again. This measure would be received because of potential unauthorized person’s intervention.

Note: Modes of Local or Remote control is conditioned by program choices of inputs I1 and I2. In the case that inputs I1 or I2 are programmed for “Local releasing”, it is only possible to control the EA by local control with active input I1 or I2.

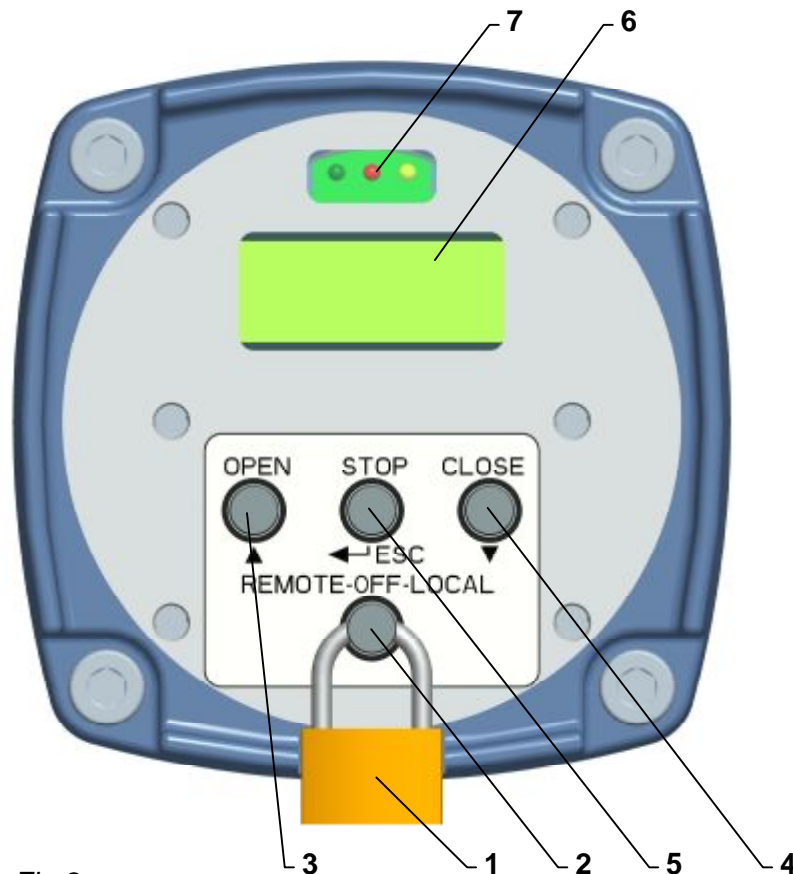

Fig.8

5.2 Maintenance – Its Scope and Periodicity

During inspections and maintenance is needed to tighten all screws and nuts that affect the tightness and coverage. Similarly, once a year should be checked and if necessary tighten mounting screws of the terminal wires and assuring of the slip-on joints with wires.

The interval between two preventive inspections is four years.

The replacement of cover gaskets and gasket of an oil filling is needed in case of damage or after 6 years of the operation.

The grease in the supplied actuators is designed for the lifetime of the product. It is not necessary to change the grease during the operation of the actuator.

Lubrication:

- gear part - in versions for climate with temperatures -25°C till $+55^{\circ}\text{C}$ – grease HF 401/0 (GLEIT- μ) resp. GLEITMO 585 K
- in versions for climate with temperatures -50°C till $+40^{\circ}\text{C}$ grease ISOFLEX TOPAS AK 50
- in versions for climate with temperatures -60°C till $+40^{\circ}\text{C}$ grease DISCOR R-EP 000.



Lubrication of the valve stem is independent on maintenance of the EA!

After every potential flooding of the product check, whether there is no water inside. After eventual water penetration, dry the product before repeated putting into operation and replace damaged sealings, resp. other parts of EA. identically check also tightness of cable bushings and replace them, if they are damaged.

Every six months it is recommended to perform one check move in frame of adjusted operation stroke to verify reliability of functioning with setting back to the original position.

If the audit rules do not determine else the inspection of EA is performed ones a year and tightening of all connecting and grounded screws have to be checked to avoid overheating.

After 6 months from putting of EA into operation and once a year it is recommended to check tightening of fixing screws between the EA and the valve. (Tighten the screws with the cross system.)

While connecting and disconnecting of the EA check the tightness of cable glands – those with damaged sealings should be replaced by new ones of the approved type!



Keep the EA clean and take care about removing impurities and dust. The cleaning has

5.3 Troubleshooting

- In case of a mains failure the EA stands in the position where it was before the failure occurred. If needed the EA can be reset using the manual control (with the handwheel). When necessary EA can be manually operated (hand wheel), at doing this, pay attention to keep the movement of the EA output part within the range of the set stroke so as to avoid losing the adjustment of the limit position switches or position transmitter or regulator. After supply voltage recovery EA is prepared for operation.
- In case of a failure of a part of the EA the part can be replaced by a new one. The exchange is to be committed by the producer or a contracted service firm.
- In case of an EA failure, which cannot be eliminated directly in operation, follow instructions for under-guaranty and after-guaranty service.

For controller repair a F1,6 A subminiature fuse for PCB should be used, alternatively also F 2A, 250 V e.g. Siba type 164 050.1,6 or MSF 250, and for DB voltage source repair a M160 mA, 250V fuse, e.g. Siba, or MSF 250.

Failure	Cause	Troubleshoot
There are no revolutions of motor rotor when operating the push-buttons.	1. No voltage on the electric motor connectors.	Check connection and voltage presence.
	2. No voltage on the control part.	Check connection of the control part.
The EA fails to stop at the limit positions.	1. Incorrect setting-up of the switches.	Perform adjustment.
	2. The microswitch is defective	Replace the microswitch for a new one and adjust.
The EA stops at the mid-position.	There is an obstacle in the valve or part of it seizes.	Perform reversing of the EA, move it to the original direction and, in the case that the failure repeats, repair the armature.
There is no indication of reaching these positions in the final positions.	1. The LEDs fail to operate.	Replace the LEDs for new ones.
	2. Incorrect adjustment of the position signal switches.	Adjust the position signal switches.
		In case that some EA failures still remain, contact the service centres.

Note: If the EA has to be dismantled follow the procedure of the Chapter "Dismantling"



The EA can be dismantled to be repair purpose by qualified and trainer persons only! The training can be preformed by the producer or by a contracted service firm.

6. Accessories and Spare Parts

As accessories the **handwheel** is packed with the product.

6.1 List of the Spare Parts

Table 5: Spare Parts

Spare part	Order Nr.	Position	Figure
Electric motor; 60 W/120 VA; 230V AC;	63 592 323	2	1
Electric motor; 90 W/150 VA; 3x400V AC;	63 592 328	2	1
Electric motor; 120 W; 230/220 V AC	63 592 394	2	1
Electric motor; 180 W/300 VA; 3x400 V AC	63 592 330	2	1
Electric motor; 120 W/300 VA; 24 V AC/DC	63 592 065	2	1
Switch CHERRY D38 with the jingle bell	64 051 738	-	2
Switch CHERRY DB 6G – B1RB	64 051 220	-	2a
Switch CHERRY DB 6G-A1LB	64 051 466	26, 27	6, 8
Sealing 230x3	62 732 119	-	-
Cable glands M16	63 456 595	-	-
Cable glands M20	63 456 596	-	-
Terminal WAGO 261-301	63 456 735	10	1

7. Enclosures

7.1 Wiring diagrams SO 2

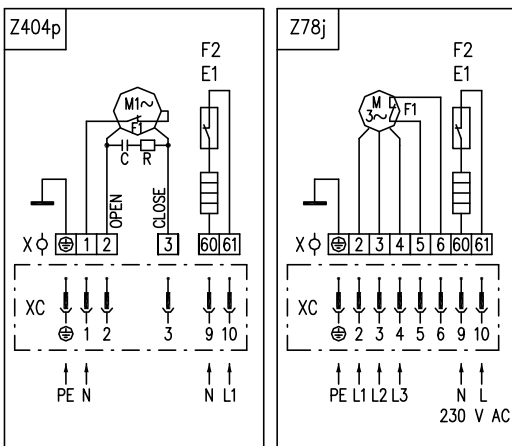
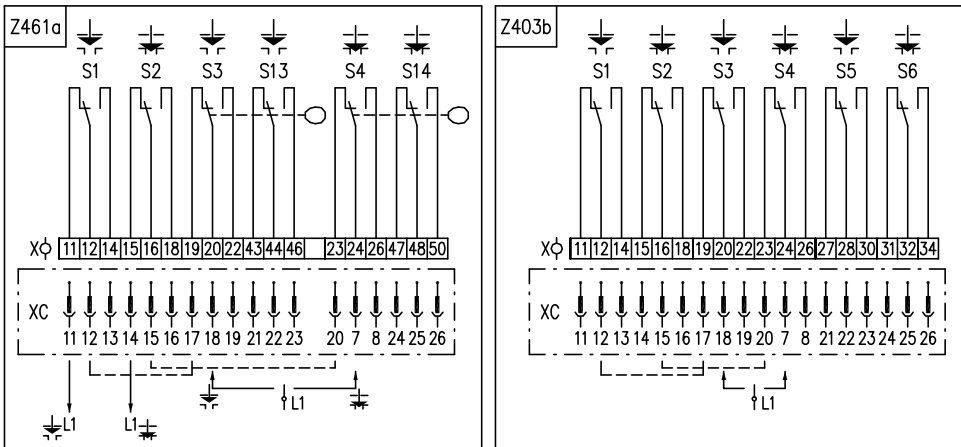
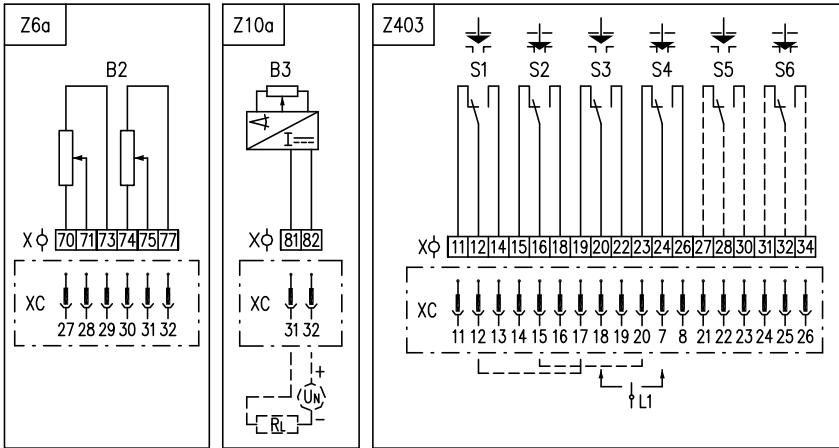
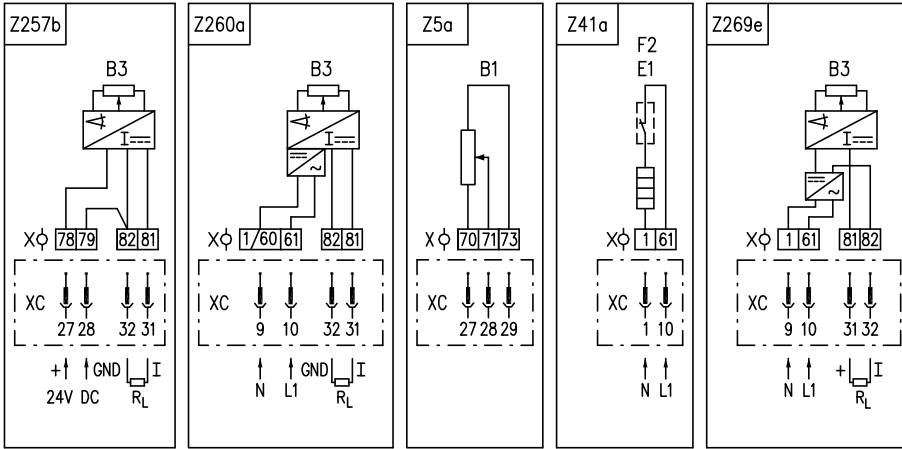

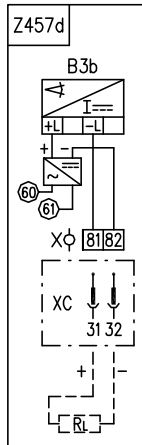
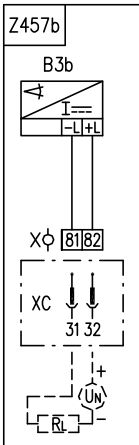
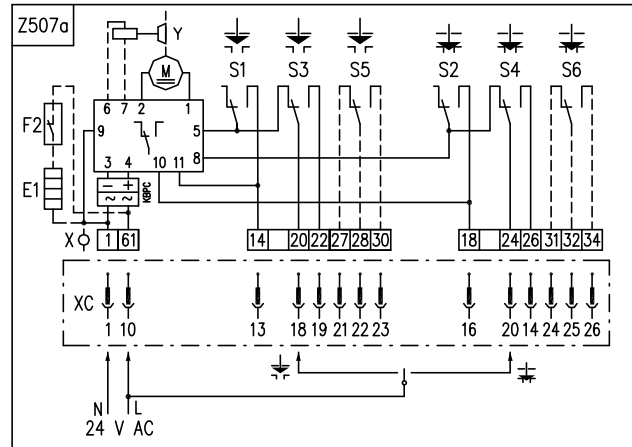
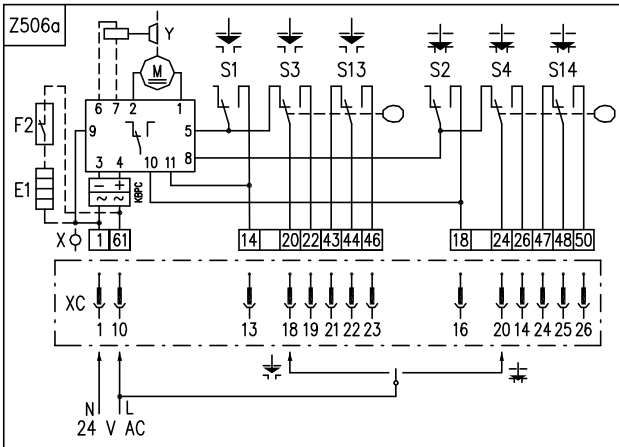
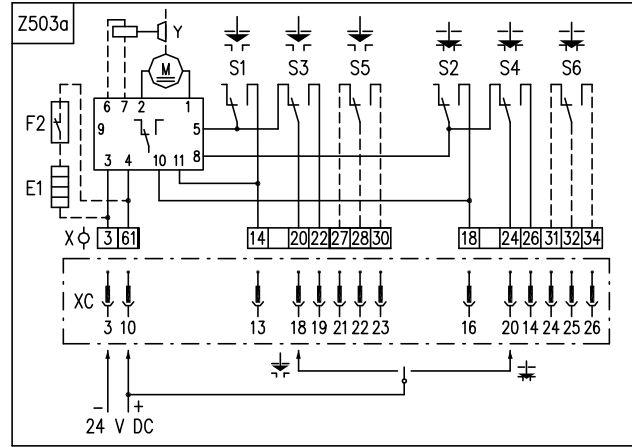
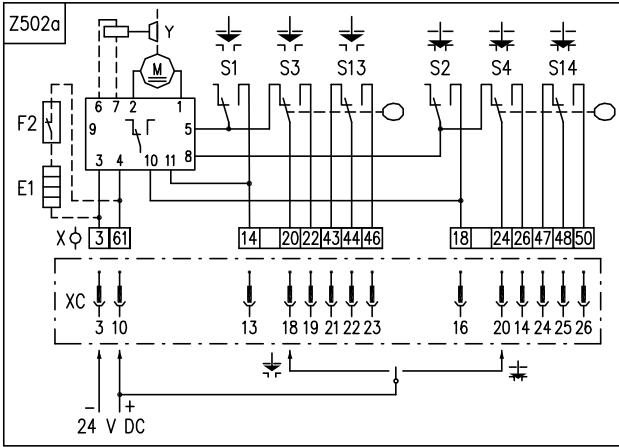

Legend:

Z5a	wiring diagram of single resistant transmitter
Z6a	wiring diagram of double resistant transmitter
Z10a	wiring diagram of resistive with current converter or capacitive transmitter - 2-wire without supply
Z257b.....	connection of resistive transmitter with current converter – 3-wire without power supply
Z260a.....	connection of resistive transmitter with current converter – 3-wire with power supply
Z269e.....	connection of resistive transmitter with current converter or capacitive transmitter – 2-wire with power supply
Z403, Z403b	wiring diagram of torque and position switches for single phase electric motor with additional brakes
Z404p.....	wiring diagram EA SO 2 with 1~ electric motor
Z78j.....	wiring diagram EA SO 2 with 3~ electric motor
Z457b.....	wiring diagram of transmitter DCPT3M with power supply
Z457d.....	wiring diagram of transmitter DCPT3M without power supply
Z41a	wiring diagram of space heater and space heater's thermal switch connection
Z461a.....	wiring diagram of torque, position and tandem switches S13, S14
Z502a.....	wiring diagram of torque, position and tandem switches S13, S14 – 24 V DC
Z503a.....	wiring diagram of EA SO 2 with electric motor 24 V DC
Z506a.....	wiring diagram of torque, position and tandem switches S13, S14 – 24 V AC
Z507a.....	wiring diagram of EA SO 2 with electric motor 24 V AC
C	capacitor
E1.....	space heater
F1.....	electric motor thermal protection
F2.....	space heater thermal switch
M.....	electric motor
R	resistor (for the version of 230 V AC)
S1.....	torque switch "open"
S2.....	torque switch "closed"
S3.....	position switch "open"
S4.....	position switch "closed"
S5.....	additional position switch "open"
S6.....	additional position switch "closed"
S13.....	tandem position switch "open"
S14.....	tandem position switch "closed"
X.....	terminal board
XC	connector
Y.....	brake of electric motor

Note 1: Thermal protection of single-phase electric motors is standardly build-in in electric motor on the neutral cable.

Note 2: Torque switching is not equipped with a mechanical interlocking device.

7.2 Switch operation chart

Switch	Terminals	open	Operating stroke	close
S1	11 - 12			
	12 - 14			
S2	15 - 16			
	16 - 18			
S3	19 - 20			
	20 - 22			
S4	23 - 24			
	24 - 26			
S5	27 - 28			
	28 - 30			
S6	31 - 32			
	32 - 34			
S13	43 - 44			
	44 - 46			
S14	47 - 48			
	48 - 50			

 Contact closed.

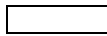
 Connected contact

Remark 1: Torque switches S1, S2 switch off when reaching the set switching-off torque in any position of the operating stroke, besides the set blocking zone at EA reversal from any position

Remark 2: The S5, S6 signaling switches are settable within the range from the end position up to a position corresponding to the 50% of the working stroke. If a larger range for signaling purposes is necessary, the reversal function of the switches is available.

Remark 3: Tandem position switches S13, S14 are switched by one cam together with position switches S3, S4.

7.3 Dimensional drawings

P-1377: Mechanical connection F07 / ISO 5210, B3, B4

P-1377

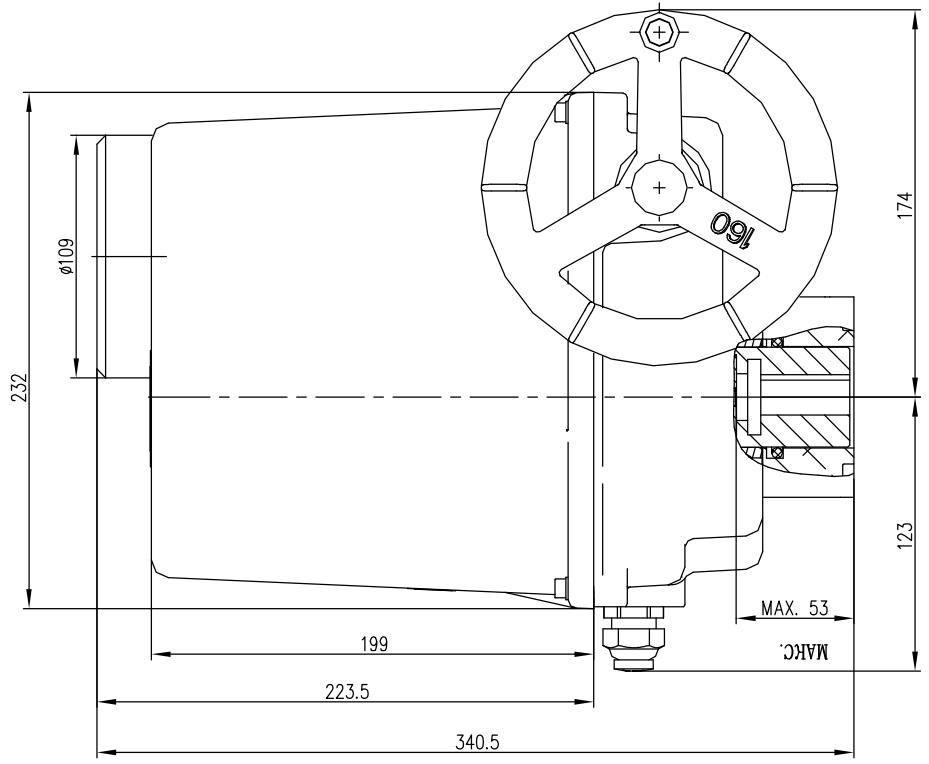
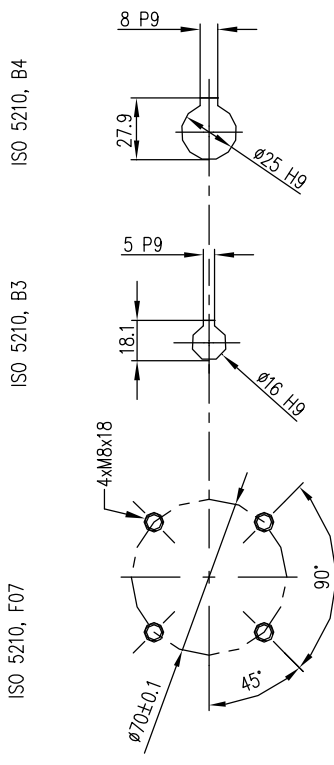
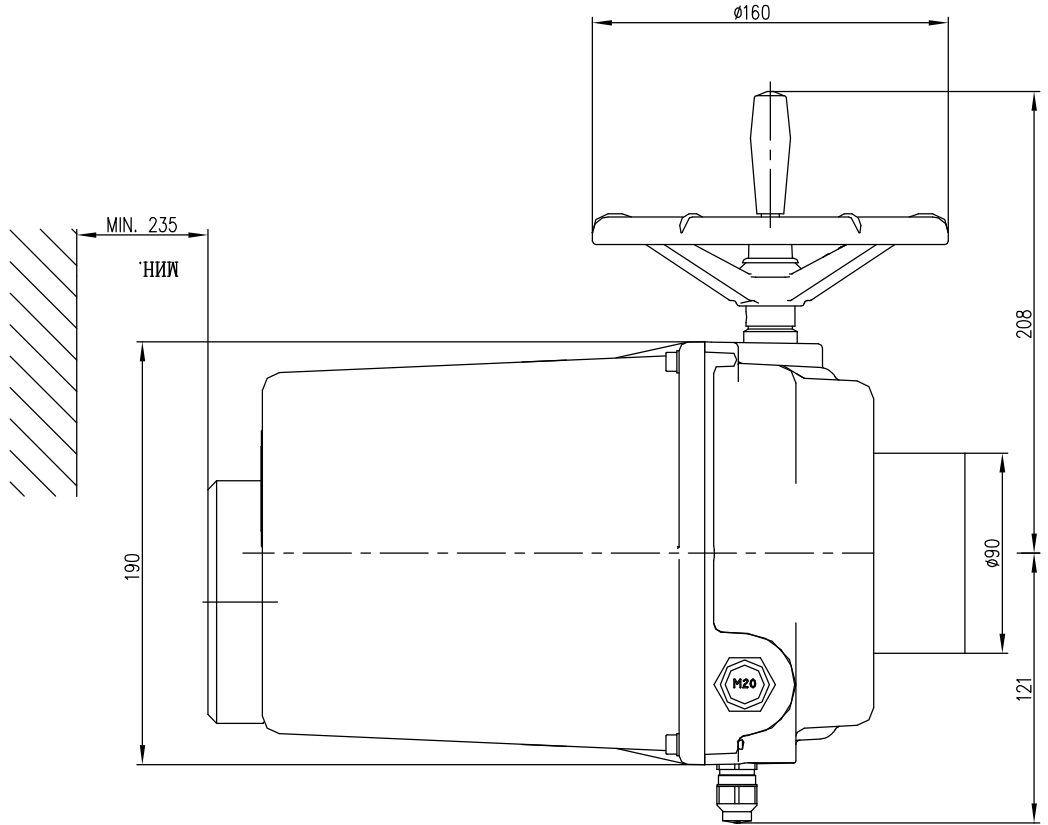

P-1379: Mechanical connection F07, F10 / non-standard

P-1379

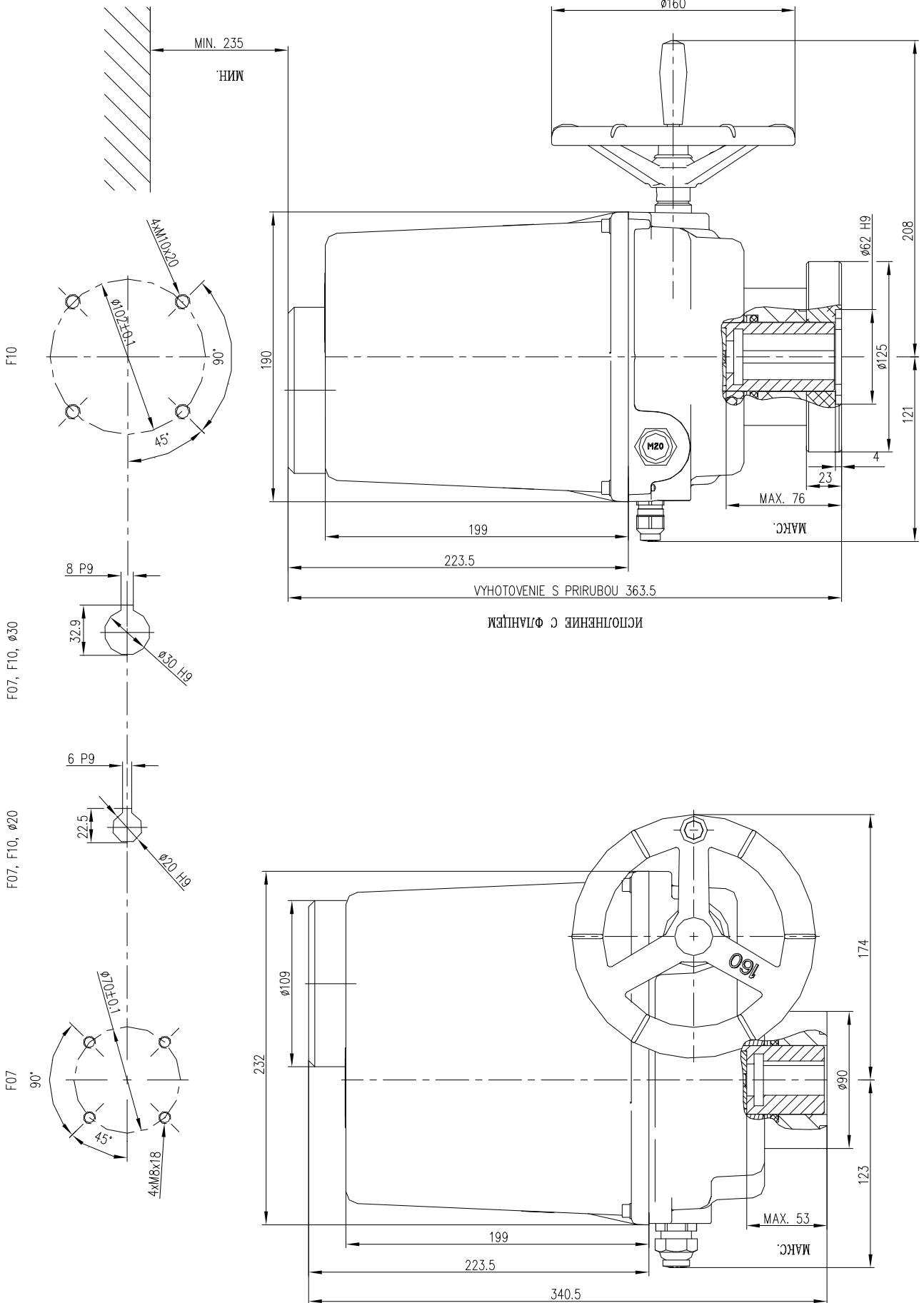

P-1380: Mechanical connection F07, F10 / ISO 5210, A

P-1380

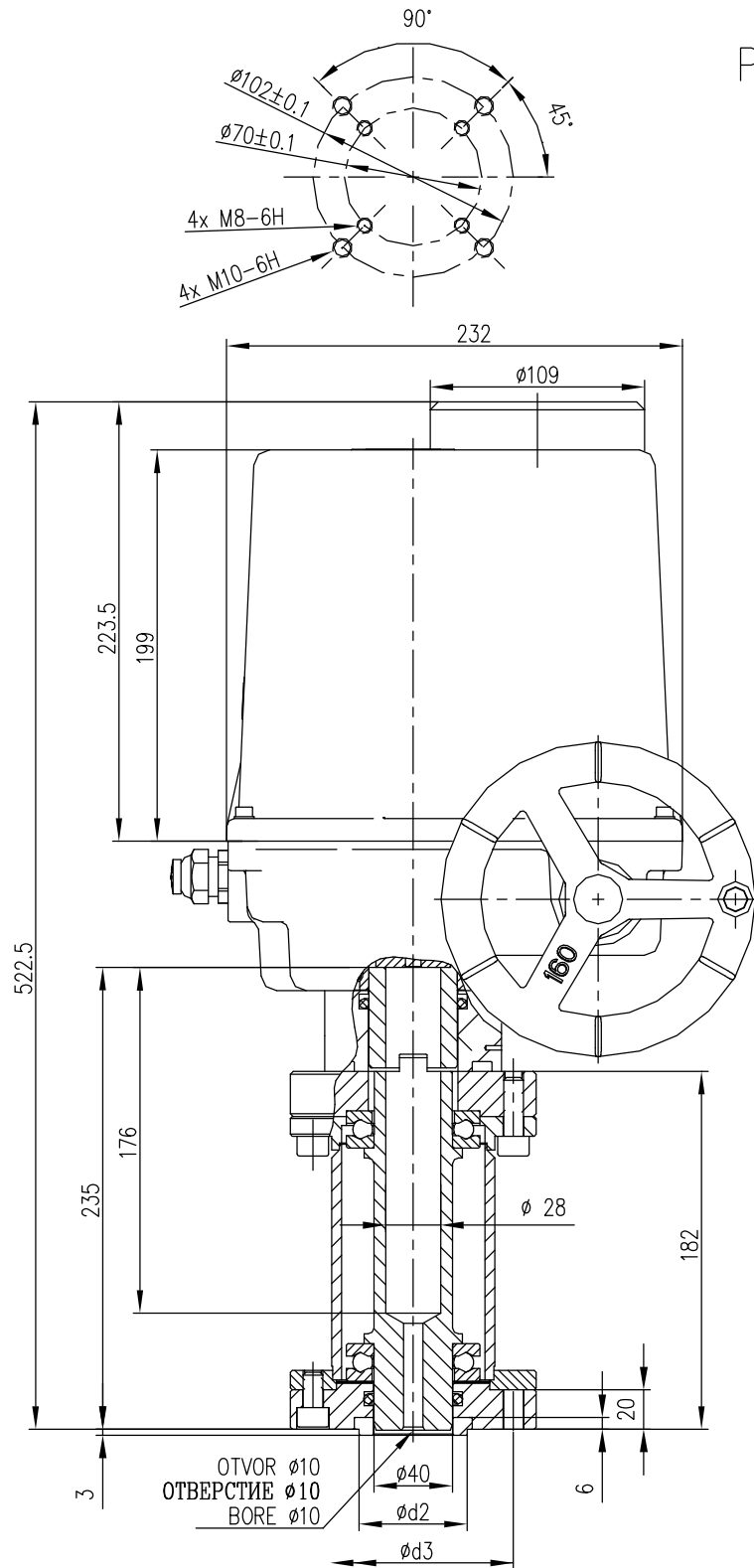

P-1380/C	60	102	не стандартное, G0-A non-standard, G0-A
P-1380/B	55	70	ISO 5210, F07-A
P-1380/A	70	102	ISO 5210, F10-A
УЫНОТОВЕНИЕ ИСПОЛНЕНИЕ VERSION	Ød2	Ød3	МЕХАНИСКЕ ПРИБОЖЕНИЕ МЕХАНИЧЕСКОЕ ПРИСОЕДИНЕНИЕ MECHANICAL CONNECTION

P-1420: Mechanical connection shape MČ

P-1420

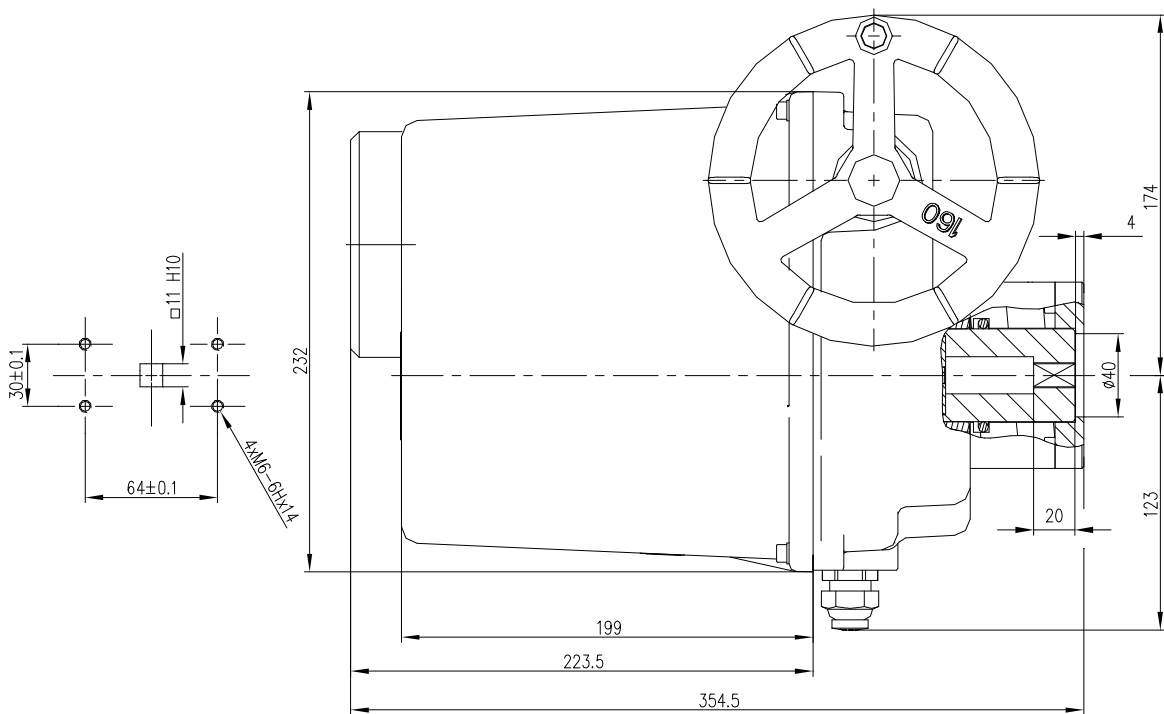
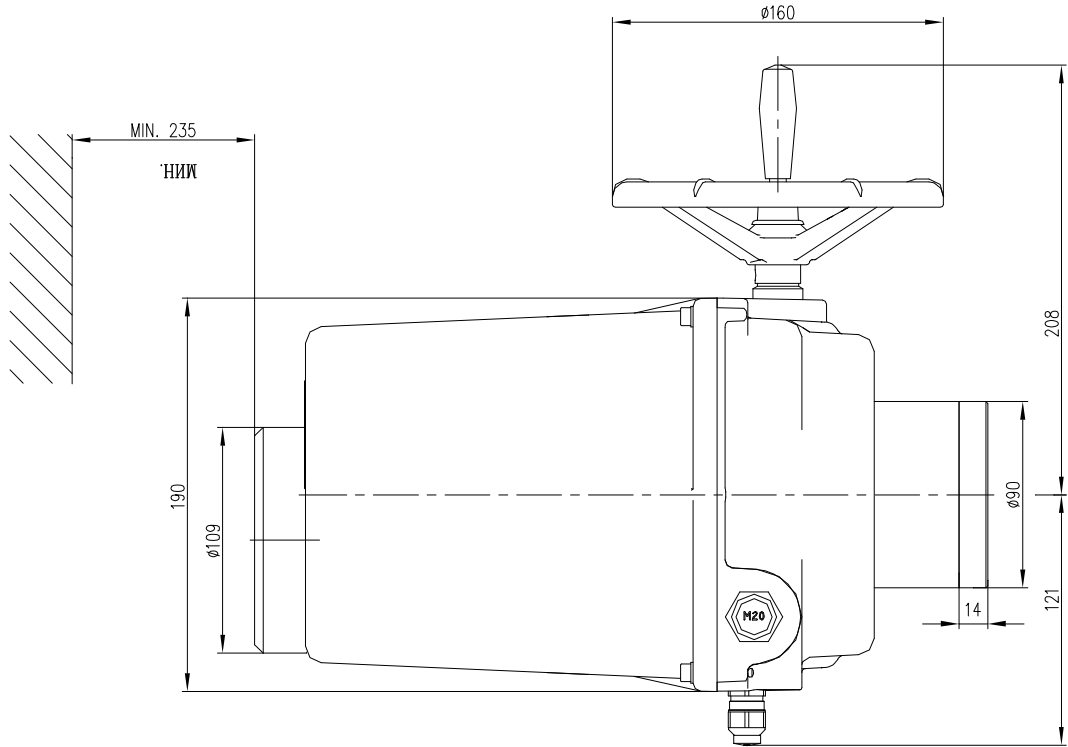

P-1453: Mechanical connection shape MK

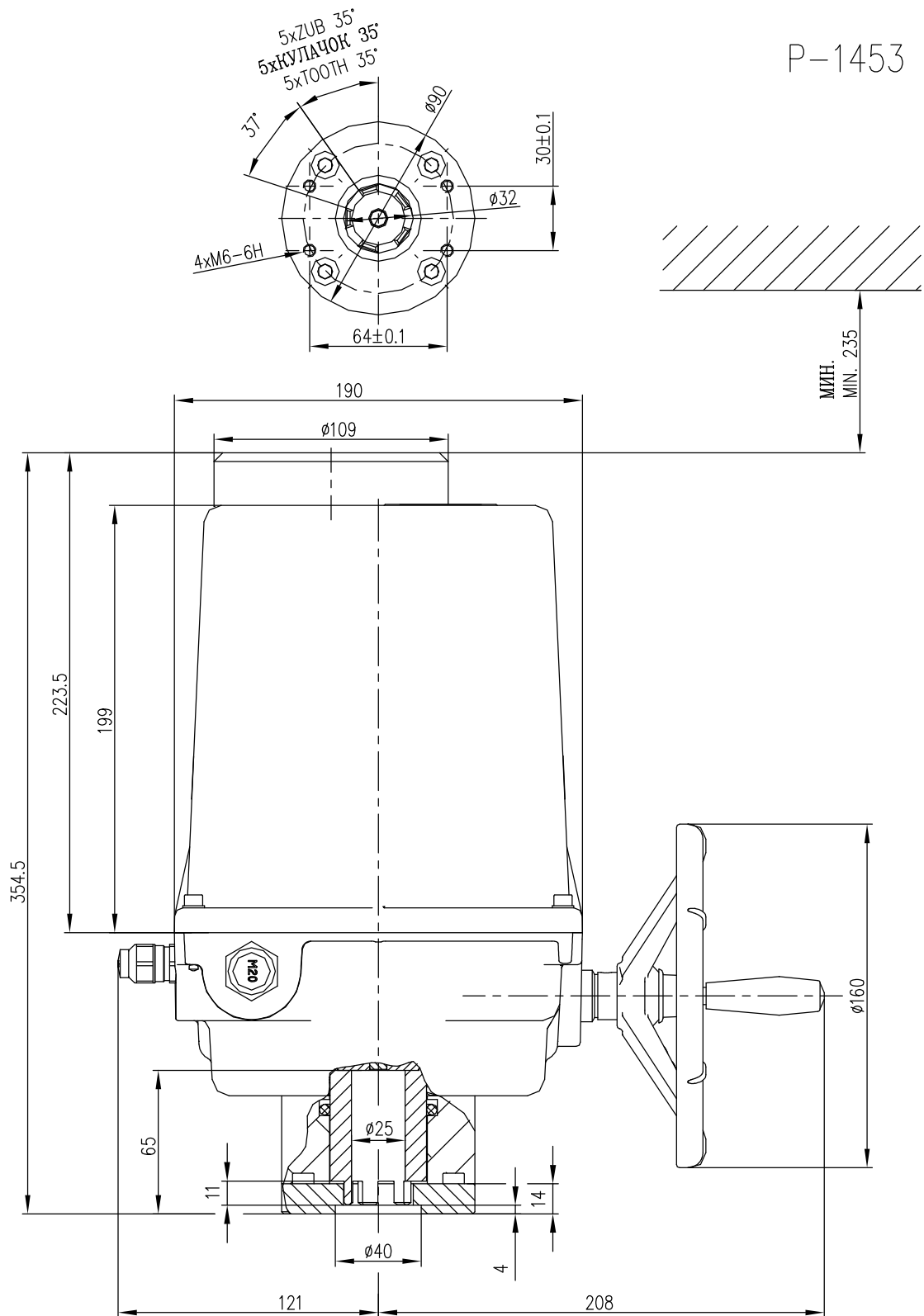

P-1454: Mechanical connection shape AČ

P-1454

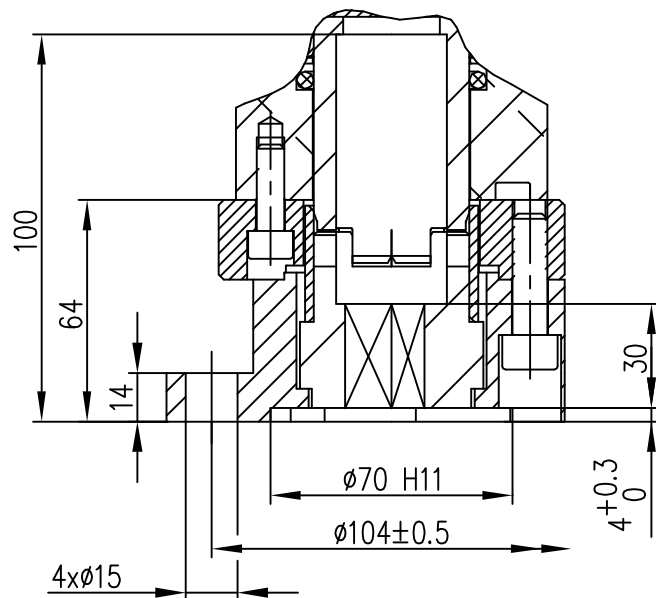
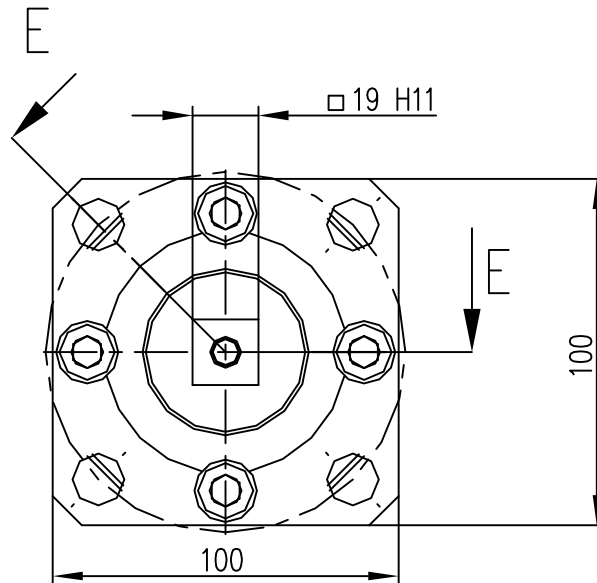

P-1452: Mechanical connection shape AK

P-1452-A/B

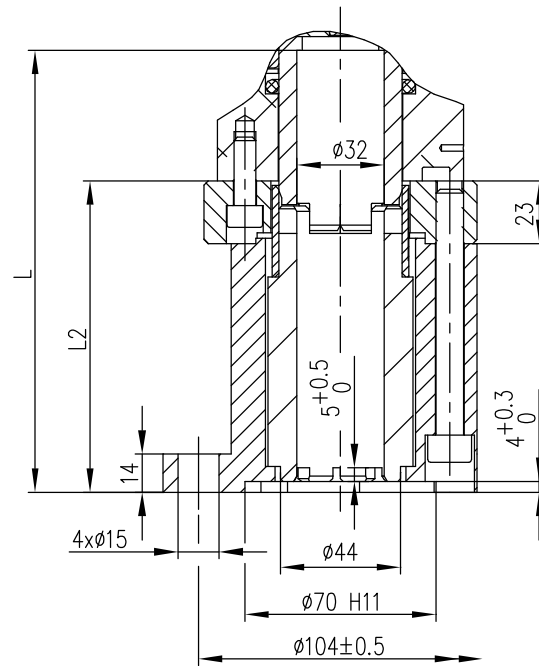
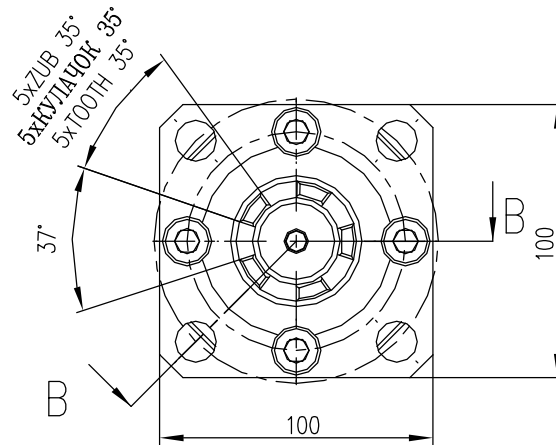

P-1452/B	114	MAX. 160
P-1452/A	64	MAX. 110
УННТОВЕНН ИСПОЛНЕНИЕ VERSION	L2	L

P-2030a

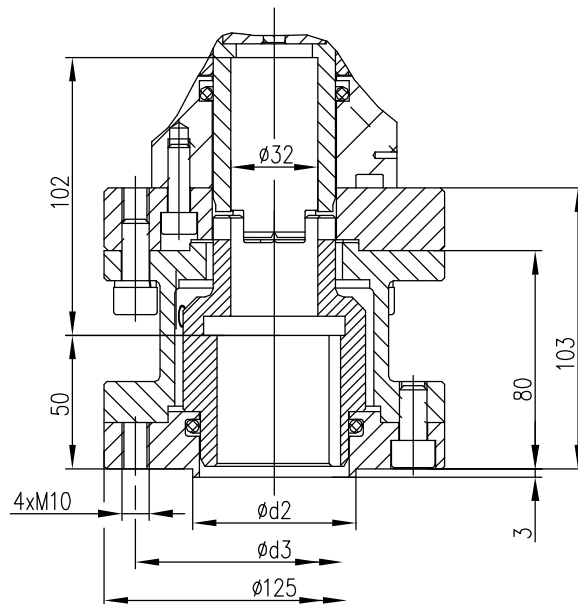
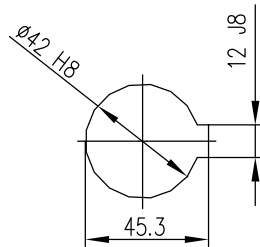

P-2030a/B	60	102	не стандартное, G0-B1 non-standard, G0-B1
P-2030a/A	70	102	ISO 5210, F10-B1
VYHOTOVENIE ИСПОЛНЕНИЕ VERSION	∅d2	∅d3	МЕХАНИЧЕСКÉ ПРИПОЈЕНЕ МЕХАНИЧЕСКОЕ ПРИСОЕДИНЕНИЕ MECHANICAL CONNECTION

P-2148 Version of SO 2 actuator with electric local control

P-2148

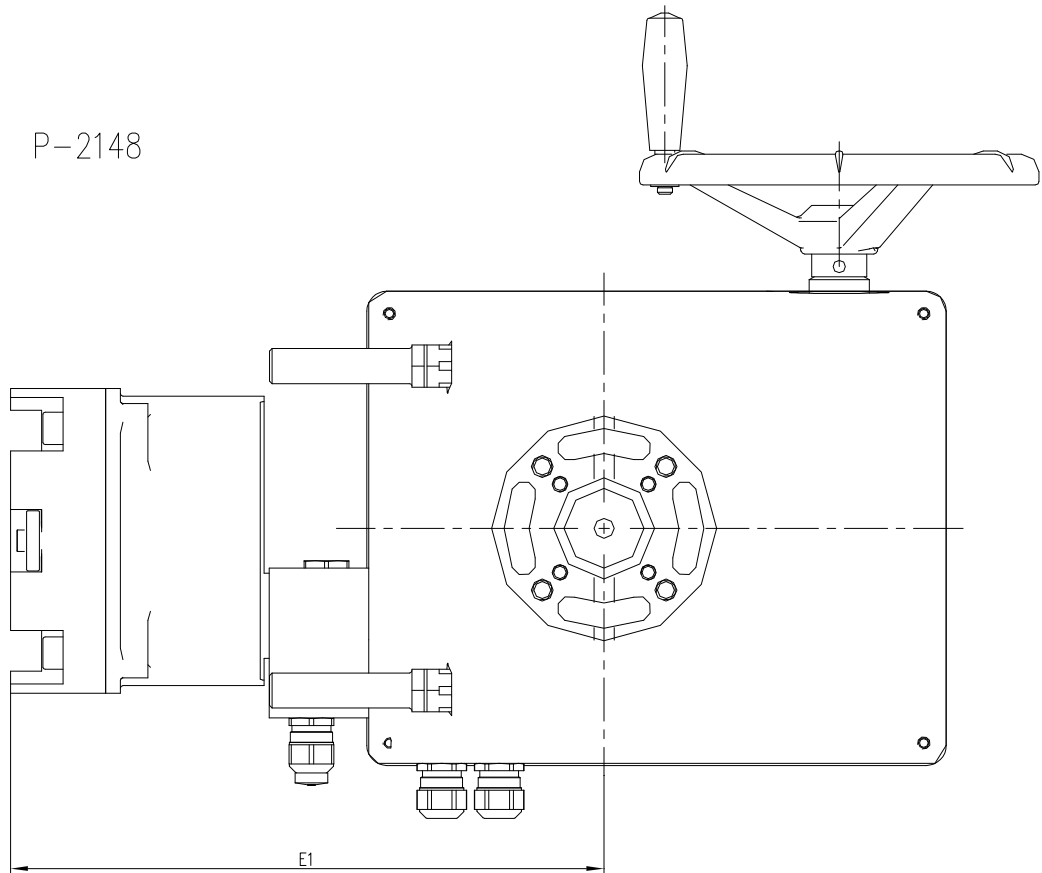

SxR 2.xPA	-50 °C	198	103.5	P-2148/J
	-25 °C	168	71.5	P-2148/I
ST 2 (-A)	-25 / -50 °C	198	103.5	P-2148/H
SO 2 (-A)	-25 / -50 °C	198	103.5	P-2148/G
SP 2.4 (-A)	-25 / -50 °C	198	103.5	P-2148/F
SP 2.3 (-A)				
SP 2 (-A)	-25 / -50 °C	238	103.5	P-2148/E
SxR 1PA	-50 °C	173	103.5	P-2148/D
	-25 °C	141	71.5	P-2148/C
ST 1 (-A)	-25 / -50 °C	173	103.5	P-2148/B
SP 1 (-A)	-25 / -50 °C	238	103.5	P-2148/A
ТYP ТИП TYPE	ТЕПЛОТА ТЕМПЕРАТУРА TEMPERATURE	E1 max. макс.	E2 max. макс.	ВУНОВОТЕНІЕ ИСПОЛНЕНІЕ VERSION

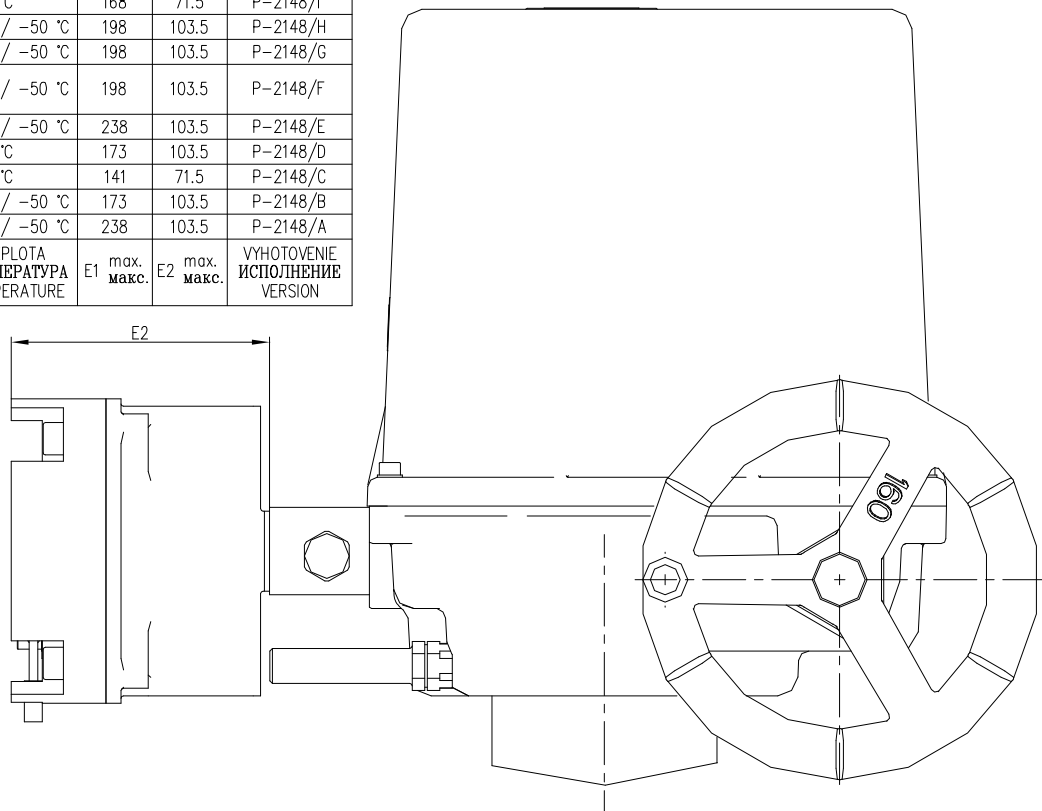

7.4 Guarantee service check report

Service center:	
Date of repair:	Guarantee repair no.:
User of actuator:	Claim applied by:
Actuator type number:	Actuator production number:
Product claim fault:	Detected product fault:
Used spare parts:	
Remarks:	
Issued on a day:	Signature:

7.5 Post guarantee service check report

Service center:	
Date of repair:	
User of actuator:	Actuator operating place :
Actuator type number:	Actuator production number:
Detected product fault:	
Used spare parts:	
Remarks:	
Issued on a day:	Signature:

7.6 Commercial representation

Slovak Republic:

Regada, s.r.o.,
Strojnícka 7,
080 01 Prešov
Tel.: +421 (0)51 7480 460,
Fax: +421 (0)51 7732 096,
E-mail: regada@regada.sk

Czech republic:

REGADA Česká s.r.o. (Ltd.) – exclusive representation REGADA, s.r.o. (Ltd.) for sale of electric actuators
Kopaninská 109
252 25 Ořech
PRAHA – západ
Tel.: +420 257 961 302
Fax: +420 257 961 301