

II 2G c Ex de IIB T5 Gb
II 2D Ex tb IIIC T100°C Db



Štandardné vybavenie:

- Napájacie napätie 230 V AC
- Svorkovnicové pripojenie
- 2 momentové spínače
- 2 polohové spínače
- 2 prídavné polohové spínače
- Výhrevný odpor s tepelným spínačom
- Mechanické koncové dorazy
- Mechanické pripojenie prírubové podľa ISO 5211
- Ručné ovládanie
- Stupeň krytia IP 67

Standard equipment:

- Voltage 230 V AC
- Terminal board connection
- 2 torque switches
- 2 position switches
- 2 additional position switches
- Space heater with thermal switch
- Mechanical stop ends
- Mechanical connection - flange ISO 5211
- Manual control
- Protection code IP 67

Špecifikačná tabuľka \Specification table\ SP 2-Ex

| | | | | | | | | | |
|------------------------------|------|---|---|---|---|---|---|---|---|
| Objednávaci kód \Order code\ | 292. | x | - | x | x | x | x | x | x |
|------------------------------|------|---|---|---|---|---|---|---|---|

| Klimatická odolnosť ¹⁰⁾ \Climate resistance\ | | Elektronický regulátor polohy \Positioner\ - N | Schéma zapojenia \Wiring diagram\ | ↓ |
|--|--------------------------|---|--|-----------------------------------|
| Vyhotovenie \Version\ | štandard \standard\ | bez regulátora \without positioner\ | nasl. tabuľka \next table\ | 1 |
| | univerzál \universal\ | bez regulátora \without positioner\ | nasl. tabuľka \next table\ | 8 |
| | štandard \standard\ | so spätnou väzbou odporovou ¹⁶⁾ \with resistive feedback\ | Z249+Z21; Z519c+Z21 Z521c+Z21 | B |
| | | | so spätnou väzbou prúdovou ¹⁷⁾ \with current feedback\ | Z254a+Z21; Z520c+Z21 Z522c+Z21 |
| | univerzál \universal\ | so spätnou väzbou odporovou ¹⁶⁾ \with resistive feedback\ | Z249+Z21; Z519c+Z21 Z521c+Z21 | K |
| | | | so spätnou väzbou prúdovou ¹⁷⁾ \with current feedback\ | Z254a+Z21; Z520c+Z21 Z522c+Z21 |

| Elektrické pripojenie \Electric connection\ | Napájacie napätie \Voltage\ | Schéma zapojenia ⁶⁾ \Wiring diagram\ | ↓ |
|--|--------------------------------|--|---|
| Na svorkovnicu \To terminal board\ | 230 V AC | Z492 ⁵⁵⁾ | 0 |
| | 3x400 V AC ⁶⁾ | Z493 ⁵⁵⁾ | 9 |
| | 24 V AC | Z524a | 3 |
| | 24 V DC | Z525a | A |

| Max. zaťažovací moment \Max. load torque\ ³³⁾ | Vypínací moment \Switching-off torque\ | Doba prestavenia ³⁴⁾ \Operating time\ | Elektromotor \Electric motor\ | | | ↓ |
|---|---|---|-------------------------------|------------|------------|---|
| | | | 230V AC | 24 V AC/DC | 3x400 V AC | |
| 63 Nm | 72 Nm | 5 s/90° ⁶⁾ | 60 W | 65 W | 90 W | 0 |
| | | 10 s/90° ⁶⁾ | | | | 1 |
| 125 Nm | 145 Nm | 20 s/90° | 20 W | - | - | 2 |
| | | 40 s/90° | | | | 3 |
| | | 80 s/90° | | | | 4 |

| Pracovný uhol \Operating angle\ | | ↓ |
|------------------------------------|-------------------------------|---|
| S pevnými dorazmi \With stop ends\ | 60° | A |
| | 90° | B |
| | 120° | C |
| | 160° | D |
| Bez dorazov \Without stop ends\ | 60° | K |
| | 90° | L |
| | 120° | M |
| | 160° | N |
| | 360° | P |
| | > 0° ≤ 360° ^{6) 41)} | Z |

Pokračovanie na ďalšej strane
\Next page\

Objednávaci kód \Order code\ 292. x - x x x x x

| Vysielač polohy ⁵⁵⁾ \Transmitter\ | | Zapojenie \Connection\ | Výstup \Output\ | Schéma zapojenia \Wiring diagram\ | |
|---|--|-------------------------------------|------------------------------------|--------------------------------------|---------------------|
| Bez vysielača \Without transmitter\ | | - | - | | A |
| Odporový \Potentiometer\ | Jednoduchý \Single\ | - | 1 x 100 Ω 1 x 2 000 Ω | Z22 | B F |
| | Dvojitý \Double\ ⁶⁾ | - | 2 x 100 Ω 2 x 2 000 Ω | Z32 | K P |
| Elektronický - prúdový \Electronic position transmitter\ | Bez zdroja \Passive \ | 2-vodič \2-wire\ | 4 - 20 mA 0 - 20 mA | Z10b | S T |
| | | 3-vodič \3-wire\ ⁶⁾ | 4 - 20 mA 0 - 5 mA | Z257d | V Y |
| | | | 2-vodič \2-wire\ | 4 - 20 mA | Z269b |
| | So zdrojom ⁵⁹⁾ \Active \ | 3-vodič \3-wire\ ⁶⁾ | 0 - 20 mA 4 - 20 mA 0 - 5 mA | Z260c | U W Z |
| | | | 2-vodič \2-wire\ ⁶⁾ | 4 - 20 mA | Z10b Z269b |
| | | So zdrojom \Active \ ⁵¹⁾ | 2-vodič \2-wire\ | 4 - 20 mA | Z254a, Z520c, Z522c |

| Mechanické pripojenie \Mechanical connection\ | | Tvar pripoj. diela \Coupling shape\ ISO | | Rozmer \Dimension\ | Rozmerový náčrt \Dimensional drawing\ | |
|--|---------|--|-------|-----------------------|--|-------|
| Príruba \Flange\ - ISO 5211 | F05/F07 | D-17 | 17x17 | P-1310 | | A |
| | | L-17 | | | | B |
| | | D-14 | 14x14 | | | E |
| | | L-14 | | | | F |
| | | H-14 | 14x22 | | | G |
| | | V-22 | ∅22 | | | H |
| | | H-13 | 13x19 | | | N |
| | | H-11 | 11x18 | | | P |
| | | H-8 | 8x13 | | | V |
| | | F07 | H-17 | | | 17x25 |
| V-28 | ∅28 | | D | | | |
| Stojan, výstupný hriadeľ, pero \Stand, output shaft, spring\ | | | | ∅25 | P-1311 P-0210 | J |
| Stojan + Veľká páka \Stand + Large lever\ | | | | - | | K |
| Stojan + Veľká páka + Ťahadlo TV 360 \Stand + Large lever + Pull-rod TV 360\ | | | | - | | L |

Poznámky:

- 6) Platí pre vyhotovenie bez regulátora.
- 10) Pozri "Pracovné prostredia" str.2.
- 16) Spätná väzba do regulátora je realizovaná odporovým vysielačom (bez udania kódu pri výbere vysielača).
- 17) Spätná väzba do regulátora je realizovaná kapacitným vysielačom (pri výbere vysielača sa udáva kód J).
- 33) Týmto momentom je možné zaťažovať servopohon v režime S2-10 min, resp. S4-25%, 6-90 cyklov/hod
Pre regulačnú prevádzku s režimom S4-25%, 90 až 1200 cyklov/hod je tento moment rovný 0.8 násobku max. zaťažovacieho momentu.
- 34) Odchýlka doby prestavenia pre DC elektromotory je -50% až +30% v závislosti od záťaže. Pre iné napätia je ± 10%.
- 41) Platí len pre vyhotovenie bez vysielača.
- 51) Len pre vyhotovenie s regulátorom s prúdovou spätnou väzbou. V tomto vyhotovení nie je výstupný signál galvanicky oddelený od vstupného signálu.
- 55) Zapojenie je limitované 21 svorkami na svorkovnici servopohonu, preto je nutné výber vysielača pre verzie 230 V AC a 3x400 V AC konzultovať s výrobcom. Niektoré svorky spínačov nebudú vyvedené na svorkovnici.
- 59) Vysielač polohy so zdrojom pre napájacie napätie 24 V DC len po dohode s výrobcom.

Notes:

- 6) Valid only for version without positioner.
- 10) See "Working environments" on page 2.
- 16) Feedback to positioner is provided by potentiometer (without selection of the order code for transmitter).
- 17) Feedback to positioner is provided by electronic transmitter (for selection of the transmitter the order code is J).
- 33) By this torque it is possible to load the actuator under duty cycle S2-10 min, or S4-25%, 6-90 cycles per hour.
For duty cycle S4-25%, 90-1200 cycles per hour this torque equals max. load torque multiplied by 0.8
- 34) Deviation of operating speed for the DC electric motor is from -50% up to +30% depending on load. For other voltages the deviation is ± 10%.
- 41) Valid only for version without transmitter.
- 51) For version with positioner with current feedback only. The output signal from the CPT transmitter is not galvanically insulated from the input signal.
- 55) Wiring connection is limited by max. number of 21 terminals on actuator's terminal board, therefore it is necessary to consult producer with your choice of position transmitter for 230 V AC and 3x400 V AC versions. Some switches will not have their connectors led out to terminal board.
- 59) Active position transmitter for version 24 V DC only after agreement with producer.

Schémy zapojenia a rozmerové náčrty \Wiring diagrams and dimensional drawings\ SP 2-Ex

Pozri str. 26, 27 \See pages 26, 27\

Elektrické pripojenie:

na svorkovnicu s 21 svorkami s prierezom pripojovacích vodičov max. 2,5 mm², cez 2 káblové vývodky pre priemer kábla 9 až 13 mm

Electric connection:

to terminal board with 21 terminals, wire cross section max. 2.5 mm², via 2 cable glands for cable diameter 9 to 13 mm

Schémy zapojenia \Wiring diagrams\ SP 2-Ex, SP 2.3-Ex, SP 2.4-Ex

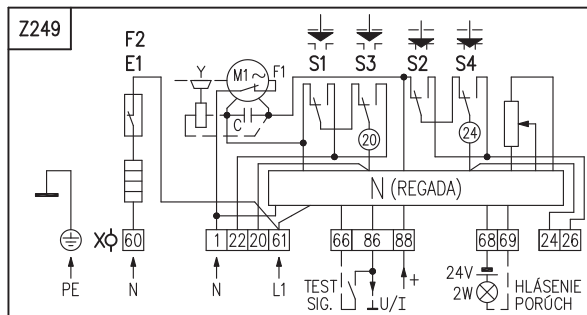
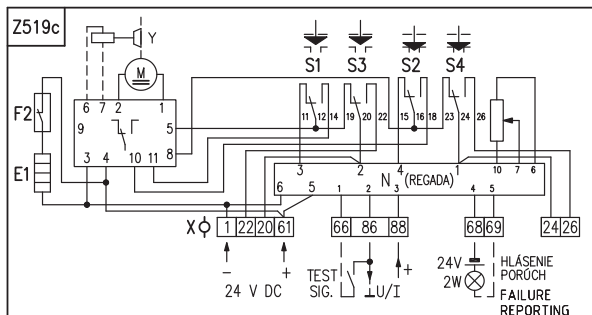
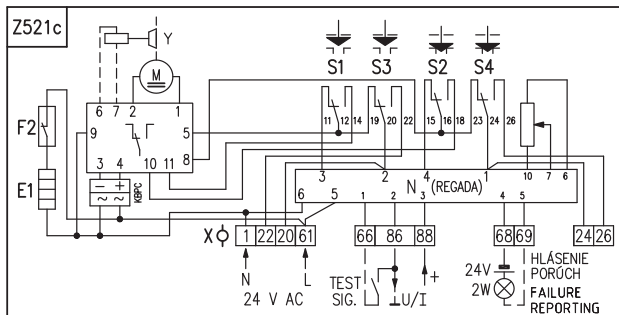
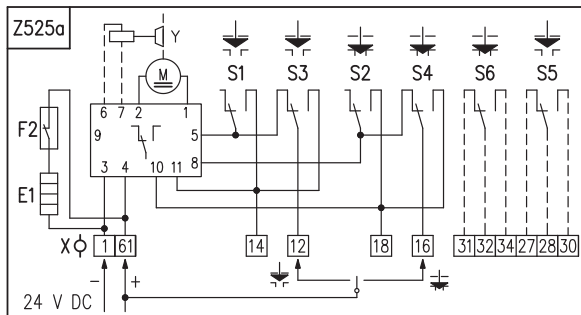
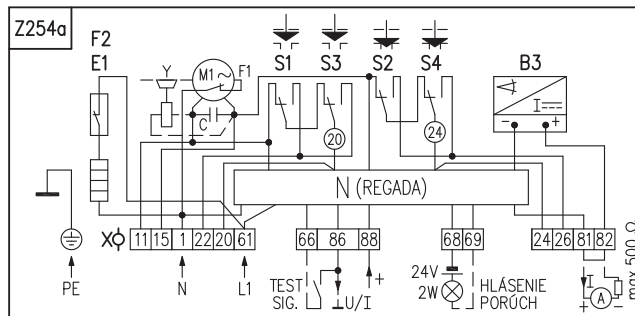
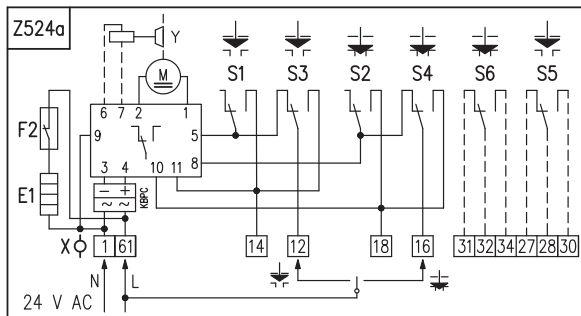
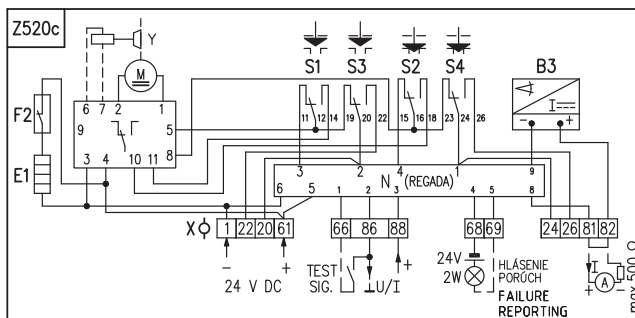
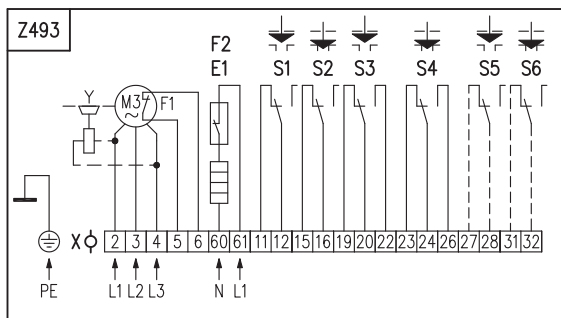
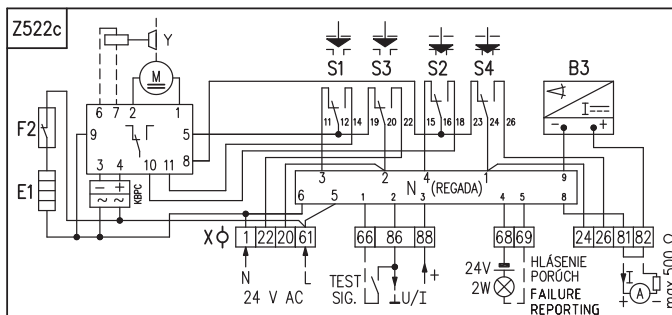
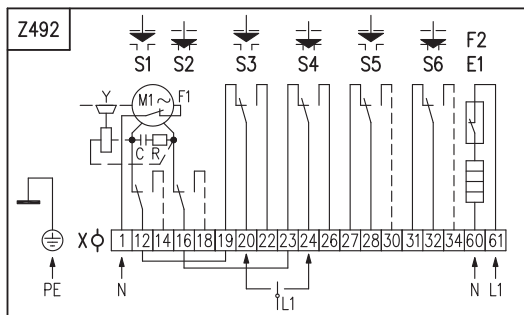

Poznámka:

1. V prípade, že výstupný signál z prúdového vysielača (schéma zapojenia Z254a, Z520c, Z522c) sa nevyužíva (neuzavretý obvod medzi svorkami 81 a 82), je nutné svorky 81 a 82 prepojiť prepajkou (prepajka je zapojená vo výrobnom závode). Pri využívaní výstupného prúdového signálu z prúdového vysielača je potrebné prepajku odstrániť.
2. Iné zapojenia servopohonov ako sú uvedené v katalógu sú možné po dohode s výrobcom.
3. Zapojenie je limitované počtom svoriek 21 na svorkovnici servopohonu.

Note:

1. In case the output signal of the CPT transmitter (wiring diagram Z254a, Z520c, Z522c) is not used (the loop between terminals 81 and 82 is open) the terminals 81 and 82 must be connected by a jumper (the jumper is placed in the plant). If the output current signal is to be used, the jumper must be removed. The output signal from the CPT transmitter is not galvanically insulated from the input signal.
2. Different wirings of actuators than shown in the catalogue are possible after agreement with producer.
3. Wiring connection is limited by max. number of 21 terminals.

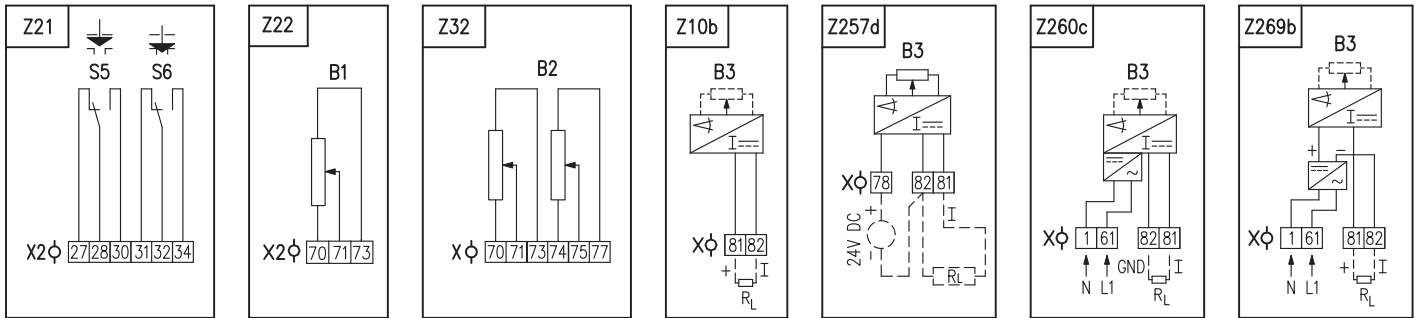

Elektrické pripojenie:

na svorkovnicu s 21 svorkami s prierezom pripojovacích vodičov max. 2,5 mm², cez 2 káblové vývodky pre priemer kábla 9 až 13 mm

Electric connection:

to terminal board with 21 terminals, wire cross section max. 2.5 mm², via 2 cable glands for cable diameter 9 to 13 mm

Legenda:

- Z10bzapojenie polohového vysielča prúdového - 2-vodič bez zdroja
- Z21zapojenie prídavných polohových snímačov pre ES s regulátorom
- Z22zapojenie jednoduchého odporového vysielča
- Z32zapojenie dvojitého odporového vysielča
- Z249zapojenie ES s regulátorom s odporovou spätnou väzbou pre napájacie napätie 230 V AC
- Z254azapojenie ES s regulátorom s prúdovou spätnou väzbou pre napájacie napätie 230 V AC
- Z257dzapojenie el. polohového vysielča prúdového - 3-vodič bez zdroja
- Z260czapojenie el. polohového vysielča prúdového - 3-vodič so zdrojom
- Z269bzapojenie polohového vysielča prúdového - 2-vodič so zdrojom
- Z492zapojenie ES pre napájacie napätie 230 V AC
- Z493zapojenie ES pre napájacie napätie 3x400 V AC

- Z519czapojenie ES s regulátorom s odporovou spätnou väzbou pre napájacie napätie 24 V DC
- Z520czapojenie ES s regulátorom s prúdovou spätnou väzbou pre napájacie napätie 24 V DC
- Z521czapojenie ES s regulátorom s odporovou spätnou väzbou pre napájacie napätie 24 V AC
- Z522czapojenie ES s regulátorom s prúdovou spätnou väzbou pre napájacie napätie 24 V AC
- Z524azapojenie ES pre napájacie napätie 24 V AC
- Z525azapojenie ES pre napájacie napätie 24 V DC

- B1.....odporový vysielča jednoduchý
- B2.....odporový vysielča dvojitý
- B3.....prúdový polohový vysielča
- S1.....momentový spínač „otvorené“
- S2.....momentový spínač „zatvorené“
- S3.....polohový spínač „otvorené“
- S4.....polohový spínač „zatvorené“
- S5.....prídavný polohový spínač „otvorené“
- S6.....prídavný polohový spínač „zatvorené“
- M.....jednosmerný elektromotor (DC)
- M1jednofázový elektromotor
- M3trojfázový elektromotor
- Ckondenzátor
- E1.....vyhrievací odpor
- F1.....tepelná ochrana elektromotora
- F2.....tepelný spínač vyhrievacieho odporu
- X,X2svorkovnica
- Nregulátor polohy
- I/Uvstupné (výst.) prúdové (napätové) signály
- Rzrážací odpor
- R_L.....zaťažovací odpor

Legenda:

- Z10bconnection of electronic or CPT position transmitter - 2-wire, passive
- Z21connection of additional position switches for the EA with positioner
- Z22connection of single potentiometer
- Z32connection of double potentiometer
- Z249connection of 230 V AC motor with positioner with resistive feedback
- Z254aconnection of 230 V AC motor with positioner with current feedback
- Z257dconnection of electronic position transmitter - 3 - wire, passive
- Z260cconnection of electronic position transmitter - 3 - wire, active
- Z269bconnection of CPT or electronic position transmitter - 2 wire - active
- Z492connection of electric motor 230 V AC, torque, position and additional position switches
- Z493connection of electric motor 3x400 V AC, torque, position and additional position switches
- Z519cconnection of 24 V DC motor with positioner with resistive feedback
- Z520cconnection of 24 V DC motor with positioner with current feedback
- Z521cconnection of 24 V AC motor with positioner with resistive feedback
- Z522cconnection of 24 V AC motor with positioner with current feedback
- Z524aconnection of electric motor 24 V AC, torque, position and additional position switches
- Z525aconnection of electric motor 24 V DC, torque, position and additional position switches

- B1.....single potentiometer
- B2double potentiometer
- B3.....CPT or electronic position transmitter
- S1.....torque switch „open“
- S2.....torque switch „closed“
- S3.....position switch „open“
- S4.....position switch „closed“
- S5.....additional position switch „open“
- S6.....additional position switch „closed“
- M.....DC electric motor
- M11-phase electric motor
- M33-phase electric motor
- Ccapacitor
- E1.....space heater
- F1.....motor's thermal protection
- F2.....space heater's thermal switch
- X,X2terminal board
- Nelectronic positioner
- I/Uinput (output) current (voltage) signals
- Rreducing resistor
- R_Lloading resistor

Rozmerové náčrty \Dimensional drawings\ SP 2-Ex, SP 2.3-Ex, SP 2.4-Ex

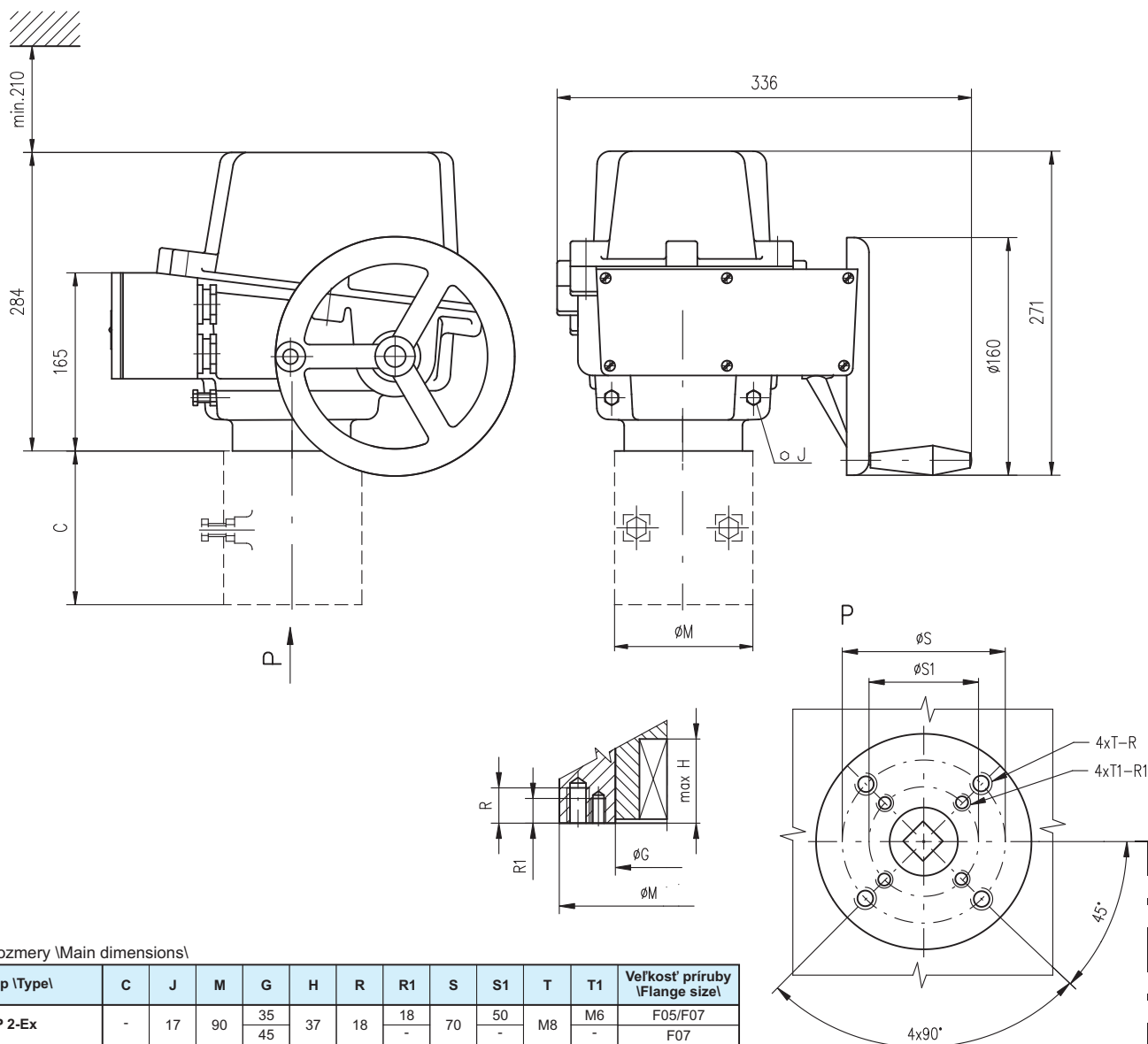

Hlavné rozmery \Main dimensions\

| Typ \Type\ | C | J | M | G | H | R | R1 | S | S1 | T | T1 | Veľkosť príruby \Flange size\ |
|------------|-----|----|-----|----|----|----|----|-----|-----|-----|-----|-------------------------------|
| SP 2-Ex | - | 17 | 90 | 35 | 37 | 18 | 18 | 70 | 50 | M8 | M6 | F05/F07 |
| | | | | 45 | | | - | | | | | F07 |
| SP 2.3-Ex | 112 | 19 | 125 | 45 | 56 | 20 | 20 | 102 | 70 | M10 | M8 | F07/F10 |
| | | | | 55 | | | - | | | | | F10 |
| SP 2.4-Ex | 127 | 22 | 150 | 65 | 71 | 25 | 25 | 125 | 102 | M12 | M10 | F10/F12 |

| Tvar pripojovacieho dielca \Coupling shape\ | | | | | | | | | | |
|---|--------------------|------------|--------------------|------------|--------------------|----|------------|--------------------|------|------|
| D-xx (Axx) | | L-xx (Bxx) | | H-xx (Cxx) | | | V-xx (Dxx) | | | |
| | | | | | | | | | | |
| ISO | Rozmer \Dimension\ | ISO | Rozmer \Dimension\ | ISO | Rozmer \Dimension\ | | ISO | Rozmer \Dimension\ | | |
| D-xx | U | L-xx | U | H-xx | U | V | V-xx | W | Z | X |
| D-14 | 14 | L-14 | 14 | H-14 | 14 | 22 | V-22 | 22.0 | 24.5 | 6.0 |
| D-17 | 17 | L-17 | 17 | H-11 | 11 | 18 | V-28 | 28.0 | 30.9 | 8.0 |
| D-22 | 22 | L-22 | 22 | H-8 | 8 | 13 | V-42 | 42.0 | 45.1 | 12.0 |
| D-27 | 27 | L-27 | 27 | H-17 | 17 | 25 | V-50 | 50.0 | 53.5 | 14.0 |
| | | | | H-13 | 13 | 19 | | | | |
| | | | | H-22 | 22 | 32 | | | | |
| | | | | H-16 | 16 | 22 | | | | |
| | | | | H-27 | 27 | 48 | | | | |
| | | | | H-19 | | | | | | |

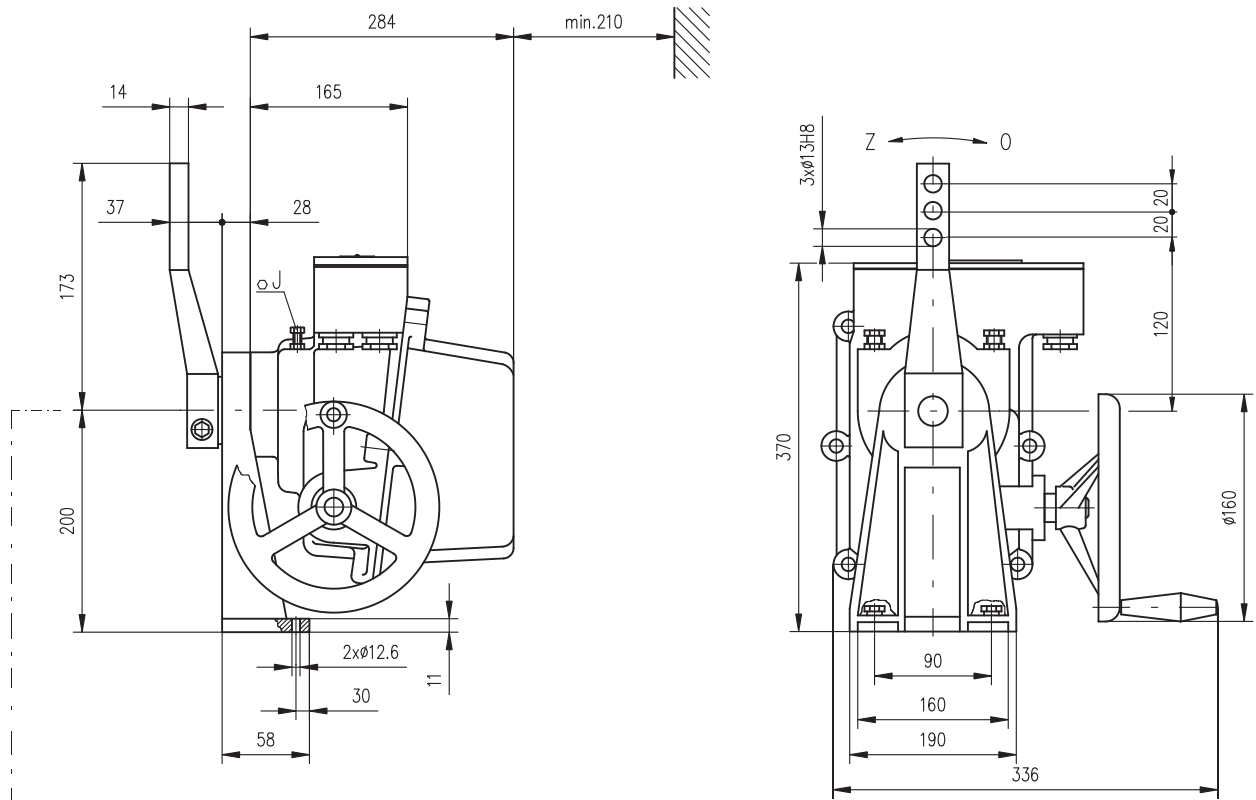

P - 1311

| Typ \Type\ | H | S | U | V | Z | Y | Y1 | Tvar pripojovacieho diela (Coupling shape) |
|------------|------|----|----|----|----|---|----|--|
| | | | | | | | | |
| SP 2-Ex | 27.9 | 25 | 8 | 35 | 28 | 2 | 2 | E02 |
| SP 2.3-Ex | 43.1 | 40 | 12 | 66 | 56 | 4 | 7 | E03 |
| SP 2.4-Ex | 53.8 | 50 | 16 | 82 | 70 | 4 | 7 | E04 |

TV 360

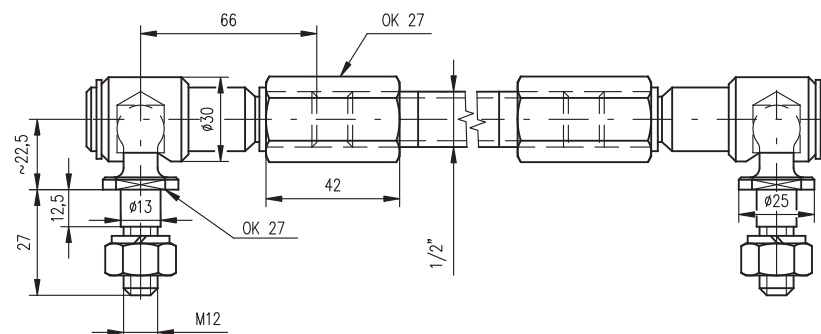

P - 0210

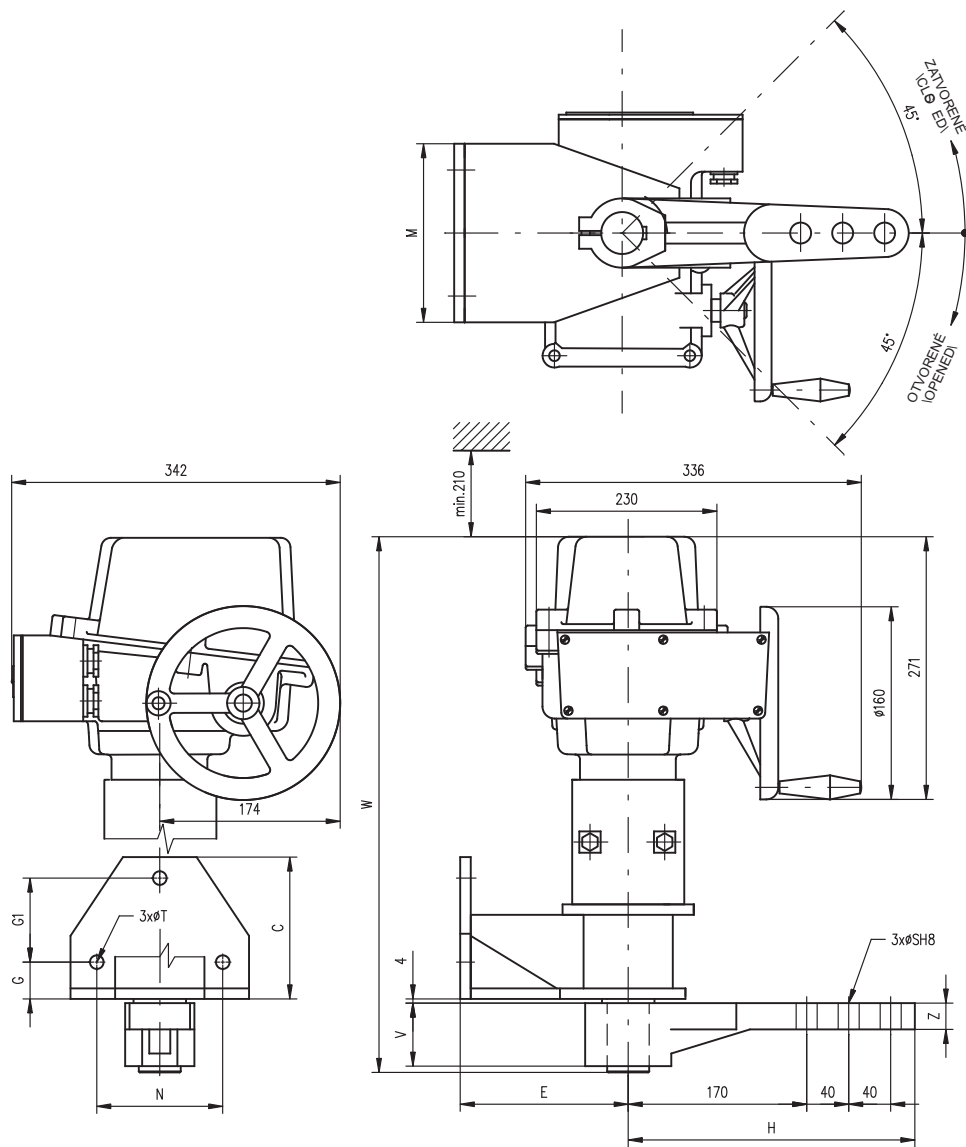

Hlavné rozmery \Main dimensions\

| Typ \Type\ | C | E | G | G1 | H | W | M | N | S | T | V | Z |
|------------|-----|-----|----|-----|-----|-----|-----|-----|----|----|----|----|
| SP 2.3-Ex | 135 | 160 | 35 | 80 | 273 | 556 | 170 | 120 | 20 | 13 | 60 | 25 |
| SP 2.4-Ex | 200 | 220 | 60 | 120 | 278 | 617 | 228 | 170 | 25 | 17 | 80 | 30 |

P - 1415

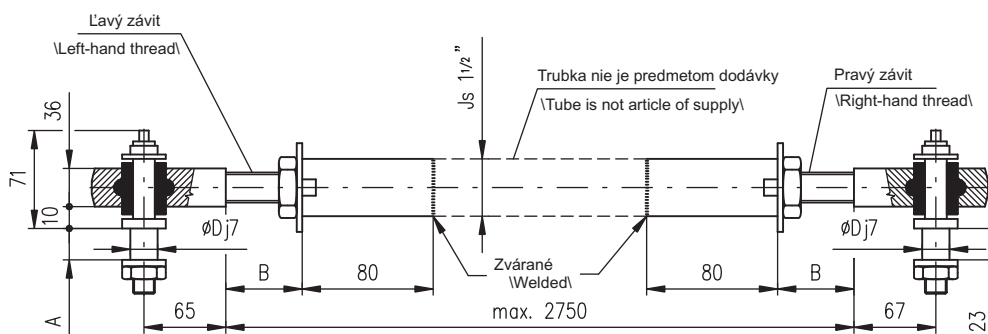

P - 1413

| | | | | |
|-----------------------|--------------------------------|----|--------|----|
| P-1413/B | TV 50-1/25 | 33 | Min.30 | 25 |
| P-1413/A | TV 40-1/20 | 23 | Max.50 | 20 |
| Vyhotovenie \Version\ | Typ ťahadla \Pull-rod version\ | A | B | D |



A large grid of small squares, typical of graph paper, covering most of the page. The grid is composed of light blue dotted lines on a white background.