



Štandardné vybavenie:

- Napájacie napätie 230 V AC
- Svorkovnicové pripojenie
- 2 momentové spínače
- 2 polohové spínače
- Mechanické koncové dorazy
- Mechanické pripojenie prírubové ISO 5211
- Miestny ukazovateľ polohy
- Ručné ovládanie
- Stupeň krytia IP 67

Standard equipment:

- Voltage 230 V AC
- Terminal board connection
- 2 torque switches
- 2 position switches
- Mechanical stop ends
- Mechanical connection - flange ISO 5211
- Mechanical position indicator
- Manual control
- Protection code IP 67

Špecifikačná tabuľka \Specification table\ SP 2.4

Objednávaci kód \Order code\ 284. x - x x x x / x x

Klimatická odolnosť ¹⁰⁾ \Climate resistance\		Korózna kategória \Corrosivity category\	Okolité teplota \Ambient temperature\	Krytie \Enclosure\	↓
Vyhovovanie \Version\	štandard \standard \	C3	-25°C + +55°C	IP 67	1
		C4	-25°C + +55°C	IP 67	2
		C3	-25°C + +55°C	IP 68 ¹¹⁾	5
	chladné \cold \	C3	-50°C + +40°C	IP 67	3
	tropické \tropics\	C3	-25°C + +55°C	IP 67	6
	morské \sea\	C4	-50°C + +40°C	IP 67	7

Elektrické pripojenie \Electric connection\	Napájacie napätie \Voltage\	Schéma zapojenia \Wiring diagram\	↓
Na svorkovnicu \To terminal board\	230 V AC	Z1a + Z11a	0
	220 V AC		L
	3x400 V AC	Z78a + Z12a ⁸⁾	9
	3x400 V AC ²⁸⁾	Z303 + Z12a ⁸⁾	2
	3x380 V AC	Z78a + Z12a ⁸⁾	M
	3x380 V AC ²⁸⁾	Z303 + Z12a ⁸⁾	N
	24 V AC	Z507a	3
Na konektor ²¹⁾ \To connector\	24 V DC	Z503a	A
	230 V AC	Z1a + Z11a	5
	220 V AC		P
	3x400 V AC	Z78a + Z12a ⁸⁾	7
	3x400 V AC ²⁸⁾	Z303 + Z12a ⁸⁾	6
	3x380 V AC	Z78a + Z12a ⁸⁾	R
	3x380 V AC ²⁸⁾	Z303 + Z12a ⁸⁾	S
24 V AC	Z507a	8	
24 V DC	Z503a	C	

Vypínací moment \Switching-off torque\	Max. zaťažovací moment ³³⁾ \Max. load torque\	230 V, 220 V AC		3x380, 3x400 V AC, 24 V AC/DC			↓
		Doba prestavenia \Operating time\	Elektromotor \Electric motor\	Doba prestavenia \Operating time\	Elektromotor \Electric motor\		
575 Nm	500 Nm	40 s/90°	60 W	40 s/90°	65 W, AC/DC	90 W	0
		80 s/90°		80 s/90°	3x400 V AC	1	
		160 s/90°	20 W	-	-	-	2

Pracovný uhol \Operating angle\		↓
S pevnými dorazmi \With stop ends\	60°	A
	90°	B
	120°	C
	160°	D
Bez dorazov \Without stop ends\	60°	K
	90°	L
	120°	M
	160°	N
	360°	P
	> 0° ≤ 360° ⁴¹⁾	Z

Pokračovanie na ďalšej strane
\Next page\

Poznámky:

8) Pre vyhotovenie s prídavnými polohovými spínačmi je možné špecifikovať dvojité vysielacie len bez vyhrievacieho odporu.

10) Pozri "Pracovné prostredia" na str. 2.

11) IP 68 - 10 m / 48 hod.

Notes:

8) For the EA version with additional position switches and double potentiometer space heater cannot be specified.

10) See "Working environment" on page 2.

11) IP 68 - 10 m / 48 hours.

Objednávací kód \ Order code \ 284. x - x x x x x x / x x

Vysielač polohy \ Transmitter \		Zapojenie \ Connection \	Výstup \ Output \	Schéma zapojenia \ Wiring diagram \		
Bez vysielača \ Without transmitter \		-	-	-	A	
Odporový \ Potentiometer \	Jednoduchý \ Single \	-	1 x 100 Ω	Z5a	B	
			1 x 2 000 Ω		F	
	Dvojitý \ Double \		2 x 100 Ω	Z6a	K	
			2 x 2 000 Ω		P	
Elektronický - prúdový \ Electronic position transmitter \	Bez zdroja \ Passive \	2-vodič \ 2-wire \	4 - 20 mA	Z10a	S	
			0 - 20 mA		T	
		3-vodič \ 3-wire \	4 - 20 mA		Z257a	V
			0 - 5 mA			Y
			4 - 20 mA			Q
	So zdrojom ⁵⁹⁾ \ Active \	2-vodič \ 2-wire \	0 - 20 mA	Z260a	U	
			4 - 20 mA		W	
		3-vodič \ 3-wire \	0 - 5 mA		Z	
			4 - 20 mA		I	
			4 - 20 mA		J	
Prúdový \ CPT \	Bez zdroja \ Passive \	2-vodič \ 2-wire \	4 - 20 mA	Z10a	I	
	So zdrojom \ Active \ ⁵⁹⁾		4 - 20 mA	Z269a	J	

Mechanické pripojenie \ Mechanical connection \		Tvar pripoj. dielca \ Coupling shape \		Rozmerový náčrt \ Dimensional drawing \	
		ISO	Rozmer \ Dimension \		
Príruba \ Flange \ ISO 5211	F10/F12	D-27	27x27	P-1147 P-1222	A
		L-27			B
		H-27	27x48 ⁶²⁾		C
		V-50	Ø50 ⁶²⁾		D
		D-22	22x22		E
		L-22			F
		H-22	22x32 ⁶²⁾		G
		V-42	Ø42		H
		-	- ⁶⁵⁾		M
		H-16	16x22 ⁶²⁾		N
		H-19	19x28 ⁶²⁾		P
		V-20	Ø20		9
		V-30	Ø30		7
		V-45.4	Ø45.4 ⁶³⁾		V
Stojan, výstupný hriadeľ, pero \ Stand, Output shaft, Key \	-	Ø50	P-1395, P-1412 P-1413/B	J	
Stojan + Páka \ Stand + Lever \	-	-		K	
Stojan + Páka + Ťahadlo TV 50-1/25 \ Stand + Lever + Pull-rod TV 50-1/25 \	-	-		L	

Rozšírené vybavenie \ Additional equipment \		Schémy zapojenia \ Wiring diagrams \					
		230 V AC	3x400 V AC	24 V AC	24 V DC		
A	2 prídavné polohové spínače \ 2 additional position switches \	Z11a	Z12a	Z507a	Z503a	0	0
E	Vyhrievací odpor s tepelným spínačom \ Space heater with thermal switch \	Z1a	Z78a	Z507a	Z503a	0	2
C	Miestne ovládanie \ Electric local controls ⁷⁰⁾	Z270i	Z90c, Z304a	Z509a	Z505a	0	7
D	Vyhrievací odpor \ Space heater \	Z1a	Z78a	Z507a	Z503a	1	5
H	Pozlátené kontakty mikrospínačov, detaily po konzultácii s výrobcou \ Gold coated contacts of microswitches, details after consultation with producer \					4	0

Dovolené kombinácie a kódy \ Allowed combination and code \:
A+E=04, A+C=08, E+C=10, A+E+C=12, A+D=16, C+D=17, A+C+D=18

Poznámky:

- 21) Vyhotovenie s konektorom len do -40°C.
Schémy zapojenia sú uvedené bez číselného označenia na konektore. Úplná schéma na požiadanie.
- 28) Vyhotovenie s reverzačnými stykačmi.
- 33) Týmto momentom je možné zaťažovať servopohon v režime S2-10 min, resp. S4-25%, 6-90 cyklov/hod.
Pre regulačnú prevádzku s režimom S4-25%, 90 až 1200 cyklov/hod je tento moment rovný 0.8 násobku max. zaťažovacieho momentu.
- 34) Odchýlka doby prestavenia pre DC elektromotory je -50% až +30% v závislosti od záťaže. Pre iné napätia je ± 10%.
- 41) Platí len pre vyhotovenie bez vysielača.
- 59) Pre napájacie napätie 24 VAC/DC po dohode s výrobcou.
- 62) Pripojovací otvor priamo vo výstupnom hriadeľi (bez výmennej vložky).
- 63) Otvor pre výmennú vložku.
- 65) Výmenná vložka. Tvar otvoru pripojovacieho dielca podľa dohody.
- 70) Local controls module only till -25°C.

Notes:

- 21) The version with connector in -40°C only.
Wiring diagrams are not showing connector pin numbers. Complete diagram on request.
- 28) Version with reverse contacts.
- 33) By this torque it is possible to load the actuator under duty cycle S2-10 min, or S4-25%, 6-90 cycles per hour.
For duty cycle S4-25%, 90-1200 cycles per hour this torque equals max. load torque multiplied by 0.8.
- 34) Deviation of operating speed for the DC electric motor is from -50% up to +30% depending on load. For other voltages the deviation is ± 10%.
- 41) Valid for version without transmitter only.
- 59) Active position transmitter for version 24 VAC/DC only after agreement with producer.
- 62) Connection bore directly within output shaft (without replaceable insert).
- 63) Bore for replaceable insert.
- 65) Replaceable insert. Profile of hole in connecting part on request.
- 70) Local controls module only till -25°C.

Schémy zapojenia \ Wiring diagrams \ SP 2.4**Elektrické pripojenie:**

- na svorkovnicu s 24 svorkami s prierezom pripojovacích vodičov 2,5 mm²,
- cez 3 kábelové vývody: - M20x1,5 pre priemer kábla 8 až 14,5 mm (1 ks),
- M16x1,5 pre priemer kábla 6 až 10,5 mm (2 ks).

Electric connection:

- to terminal board with 24 clamps, wire cross section 2.5 mm²,
- via 3 cable glands: - M20x1.5 for cable diameter 8 to 14.5 mm (1 piece),
- M16x1.5 for cable diameter 6 to 10.5 mm (2 pcs.).

Schémy zapojenia Wiring diagrams \ SP 1, SP 2, SP 2.3, SP 2.4

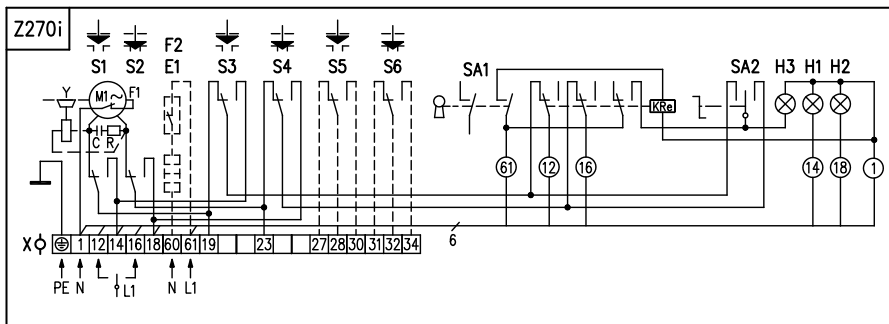
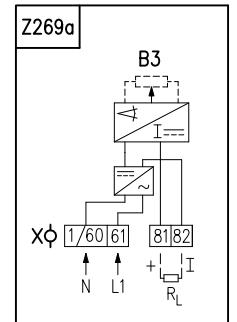
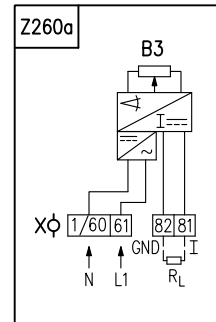
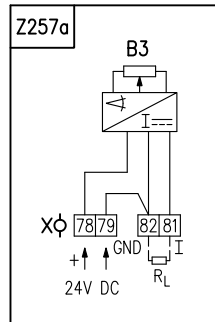
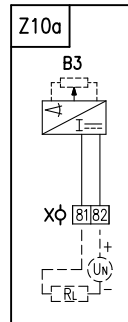
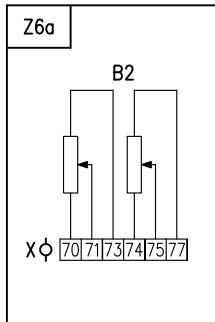
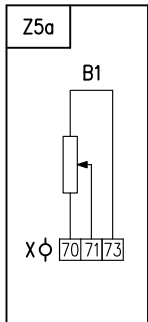
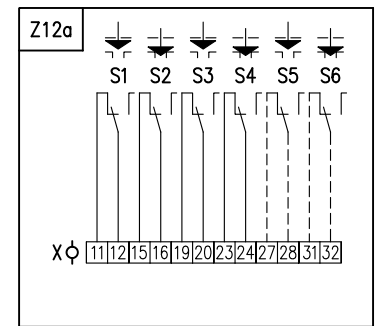
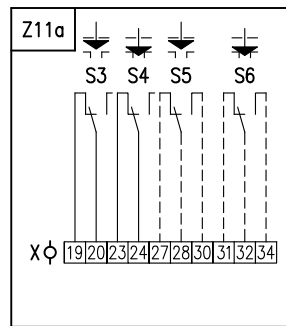
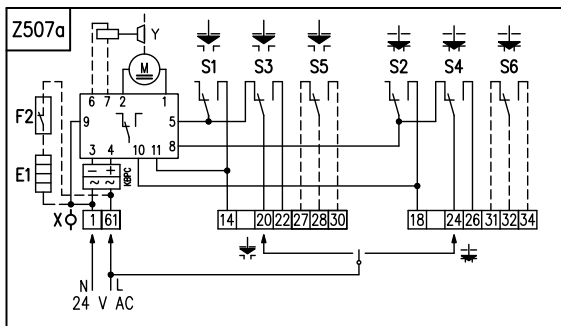
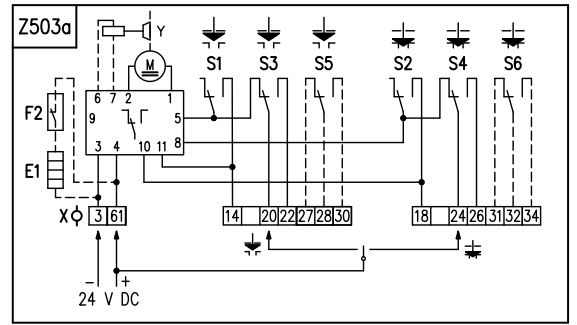
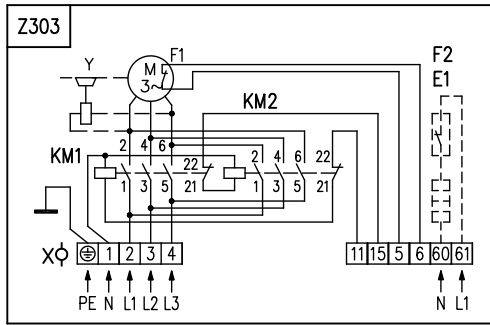
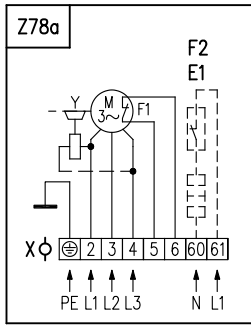
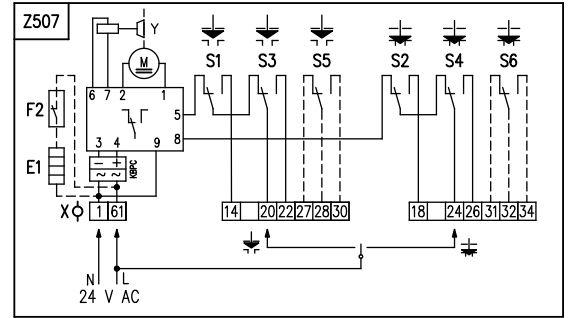
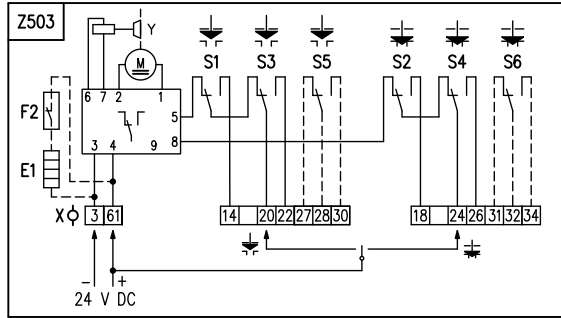
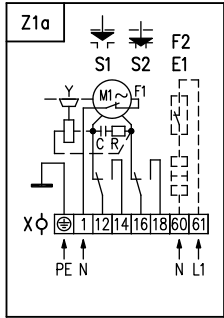

Poznámky:

1. Zapojenie je limitované počtom svoriek 24 na svorkovnici servopohonu.
2. Elektromotory sú štandardne vybavené tepelnou ochranou.
3. Vo vyhotovení ES s napájacím napätím 24 V AC nie je potrebné pripojiť zemiaci vodič PE.
4. Iné zapojenia servopohonov ako sú uvedené v katalógu sú možné po dohode s výrobcom.

Notes:

1. Wiring connection is limited by max. number of 24 terminals.
2. Electric motors are equipped with thermal protection as standard.
3. The version of EA with supply voltage of 24V AC does not require connecting of an earthing cable PE.
4. Different wirings of actuators than shown in the catalogue are possible after agreement with producer.

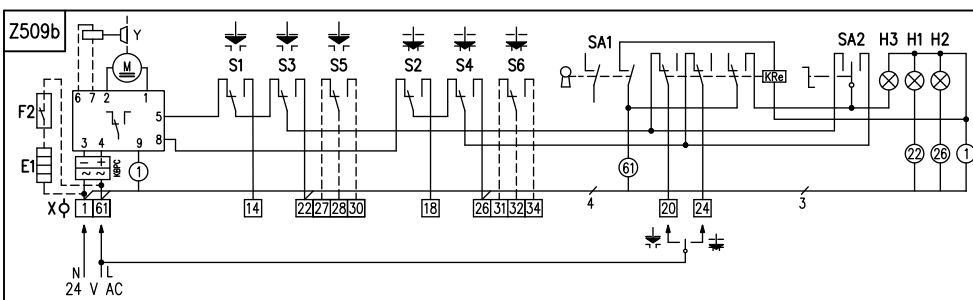
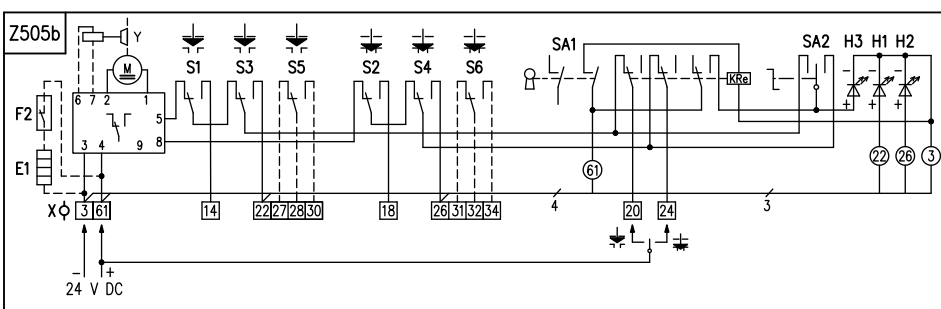
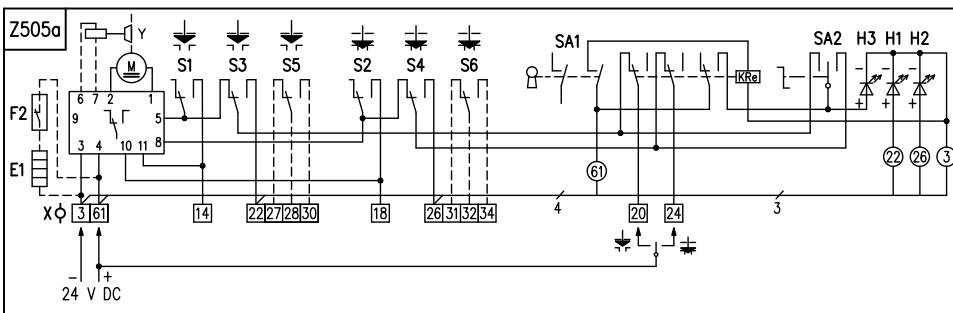
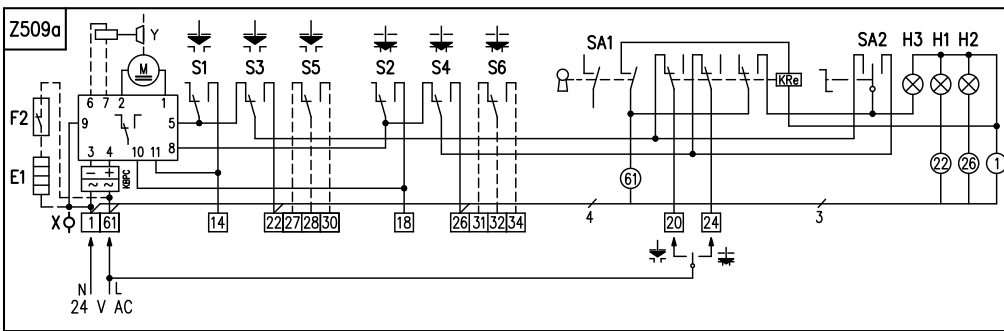
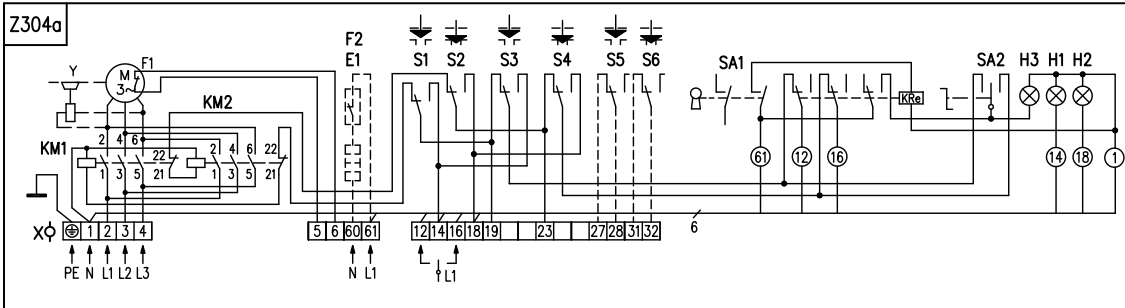
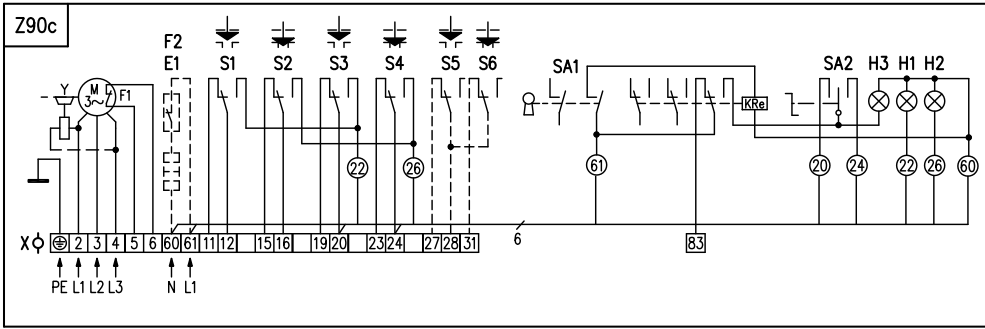

Legenda:

Z1azapojenie 1-fázového elektromotora
 Z5azapojenie jednoduchého odporového vysieláča polohy
 Z6azapojenie dvojitého odporového vysieláča polohy
 Z10azapojenie polohového vysieláča prúdového - 2-vodič bez zdroja
 Z11azapojenie polohových spínačov pre 1-fázový elektromotor
 Z12azapojenie polohových spínačov pre 3-fázový elektromotor
 Z78azapojenie 3-fázového elektromotora
 Z90czapojenie 3-fázového elektromotora s miestnym ovládaním
 Z257azapojenie el. polohového vysieláča prúdového - 3-vodič bez zdroja
 Z260azapojenie el. polohového vysieláča prúdového - 3-vodič so zdrojom
 Z269azapojenie polohového vysieláča prúdového - 2-vodič so zdrojom
 Z270izapojenie 1-fázového elektromotora s miestnym ovládaním
 Z303zapojenie 3-fázového elektromotora s reverzačnými stýkačkami
 Z304azapojenie 3-fázového elektromotora s reverzačnými stýkačkami a miestnym ovládaním
 Z503zapojenie SP 1 s ektromotorom 24 V DC
 Z503azapojenie SP 2, SP 2.3, SP 2.4 s ektromotorom 24 V DC
 Z505azapojenie SP 2, SP 2.3, SP 2.4 s ektromotorom 24 V DC s miestnym ovládaním
 Z505bzapojenie SP 1 s ektromotorom 24 V DC s miestnym ovládaním
 Z507zapojenie SP 1 s ektromotorom 24 V AC
 Z507azapojenie SP 2, SP 2.3, SP 2.4 s ektromotorom 24 V AC
 Z509azapojenie SP 2, SP 2.3, SP 2.4 s ektromotorom 24 V AC s miestnym ovládaním
 Z509bzapojenie SP 1 s ektromotorom 24 V AC s miestnym ovládaním

B1odporový vysieláč jednoduchý
 B2odporový vysieláč dvojitý
 B3polohový vysieláč prúdový
 S1momentový spínač „otvorené“
 S2momentový spínač „zatvorené“
 S3polohový spínač „otvorené“
 S4polohový spínač „zatvorené“
 S5prídavný polohový spínač „otvorené“
 S6prídavný polohový spínač „zatvorené“
 Melektromotor
 Ckondenzátor
 Ybrzda elektromotora
 E1vyhrievací odpor
 F1tepelná ochrana elektromotora
 F2tepelný spínač vyhrievacieho odporu
 Xsvorkovnica
 Ivýstupný signál prúdový
 H1indikácia koncovej polohy „otvorené“
 H2indikácia koncovej polohy „zatvorené“
 H3indikácia režimu „miestne ovládanie“
 SA1otočný prepínač s kľúčom „dialkové - 0 - miestne“ ovládanie
 SA2otočný prepínač „otvára - stop - zatvára“
 Rzrážací odpor
 R_Lzaťažovací odpor
 KMreverzný stýkač

Legend:

Z1aconnection of 1-phase electric motor
 Z5aconnection of single potentiometer
 Z6aconnection of double potentiometer
 Z10aconnection of CPT or electronic position transmitter - 2 - wire, passive
 Z11aconnection of position switches for 1-phase electric motor
 Z12aconnection of position switches for 3-phase electric motor
 Z78aconnection of 3-phase electric motor
 Z90cconnection of 3-phase electric motor with local controls
 Z257aconnection of electronic position transmitter - 3 - wire, passive
 Z260aconnection of electronic position transmitter - 3 - wire, active
 Z269aconnection of CPT or electronic position transmitter - 2 wire - active
 Z270iconnection of 1-phase electric motor with local controls
 Z303connection of 3 - phase electric motor with reverse contactors
 Z304aconnection of 3 -phase electric motor with reverse contactors and with local controls
 Z503conection of SP 1 with electric motor 24 V DC
 Z503aconection of SP 2, SP 2.3, SP 2.4 with electric motor 24 V DC
 Z505aconection of SP 2, SP 2.3, SP 2.4 with electric motor 24 V DC with local controls
 Z505bconection of SP 1 with electric motor 24 V DC with local controls
 Z507conection of SP 1 with electric motor 24 V AC
 Z507aconection of SP 2, SP 2.3, SP 2.4 with electric motor 24 V AC
 Z509aconection of SP 2, SP 2.3, SP 2.4 with electric motor 24 V AC with local controls
 Z509bconection of SP 1 with electric motor 24 V AC with local controls

B1single potentiometer
 B2double potentiometer
 B3CPT or electronic position transmitter
 S1torque switch „open“
 S2torque switch „closed“
 S3position switch „open“
 S4position switch „closed“
 S5additional position switch „open“
 S6additional position switch „closed“
 Melectric motor
 Ccapacitor
 Ymotor's brake
 E1space heater
 F1motor's thermal protection
 F2space heater's thermal switch
 Xterminal board
 Ioutput current signal
 H1indication of „open“ limit position
 H2indication of „closed“ limit position
 H3indication of „electric local control“
 SA1rotary switch with key „remote - 0 - electric local“ control
 SA2rotary switch „opening - stop - closing“
 Rreducing resistor
 R_Lloading resistor
 KMreverse contactor

Rozmerové náčrty \Dimensional drawings\ SP 1, SP 2, SP 2.3, SP 2.4

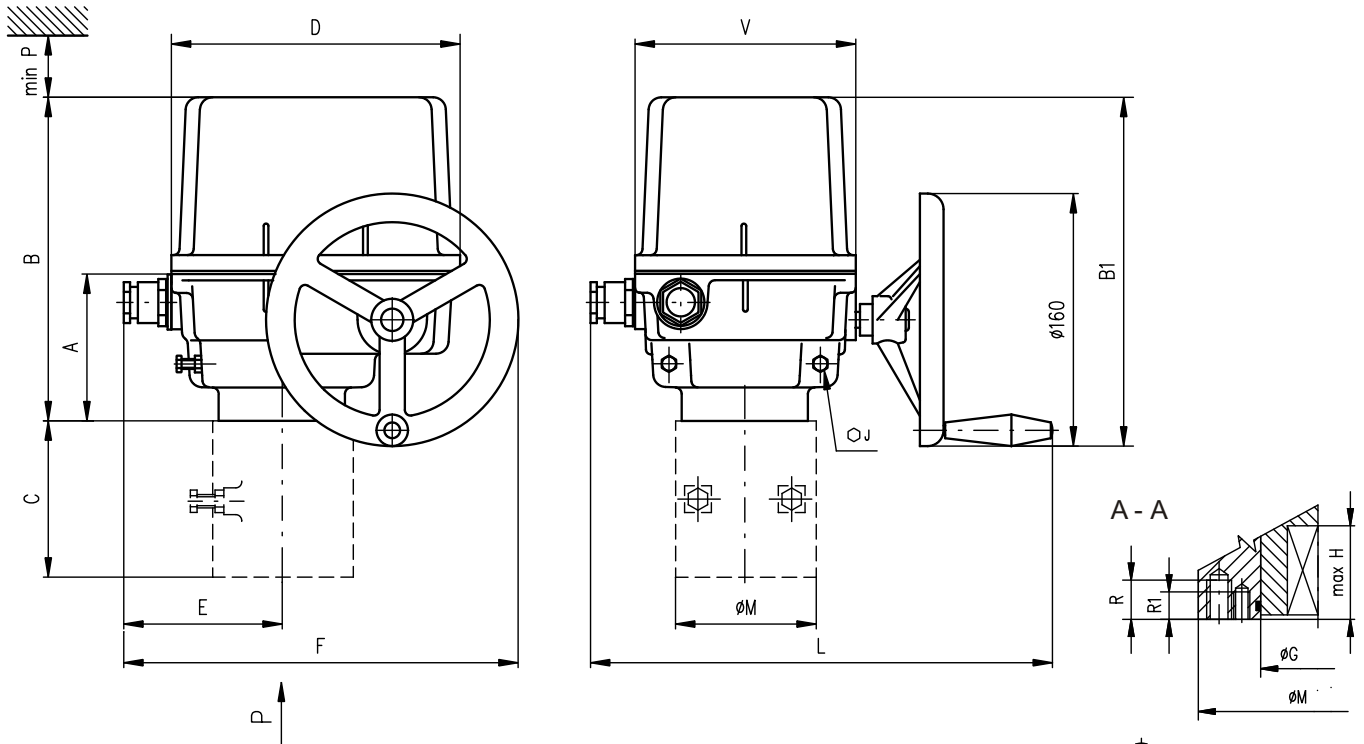

Hlavné rozmery \Main dimensions\

Typ \Type\	A	B	B1	C	D	E	F	J	L	M	P	V
SP 1	102	223	239	-	183	93	243	13	280 396*	90	160	140
SP 2	117	284	291	-	234	119	294	17	330 446*	90	210	190
SP 2.3				19				125				
SP 2.4				22				150				

* platí pre vyhotovenie s konektorom \valid for version with a connector\

Rozmery prírub \Flange dimensions\

Typ \Type\	G	H	R	R1	S	S1	T	T1	Veľkosť príruby \Flange size\
SP 1	40	37	16	12	70	50	M8	M6	F07/F05
SP 2	40	49	16	12	70	50	M8	M6	F07/F05
SP 2.3	55	56	20	16	102	70	M10	M8	F10/F07
SP 2.4	65	71	24	20	125	102	M12	M10	F12/F10

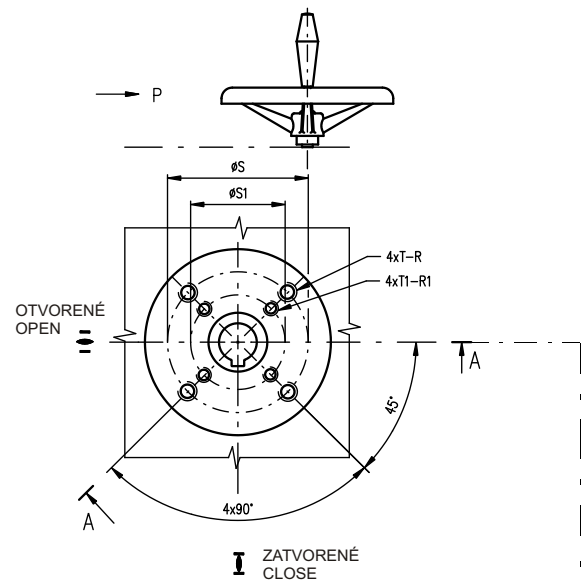

Tvar pripojovacieho dielca \Coupling shape\										
D-xx		L-xx		H-xx		V-xx		V-30, V-45.4		
ISO	Rozmer \Dimension\	ISO	Rozmer \Dimension\	ISO	Rozmer \Dimension\		ISO	Rozmer \Dimension\		
D-xx	U	L-xx	U	H-xx	U	V	V-xx	W	Z	X
D-14	14	L-14	14	H-14	14	22	V-20	20.0	22.5	6.0
D-17	17	L-17	17	H-11	11	18	V-22	22.0	24.5	6.0
D-22	22	L-22	22	H-8	8	13	V-32.2	32.2	35	6.5
D-27	27	L-27	27	H-17	17	25	V-17	17.0	19.5	6.0
D-11	11	L-11	11	H-13	13	19	V-28	28.0	30.9	8.0
D-16	16	L-16	16	H-22	22	32	V-42	42.0	45.1	12.0
				H-16	16	22	V-45.4	45.4	48.8	10.0
				H-27	27	48	V-50	50.0	53.5	14.0
				H-19	19	28	V-18	18.0	20.5	6.0
				H-10	10	16	V-30	30.0	32.5	8.0

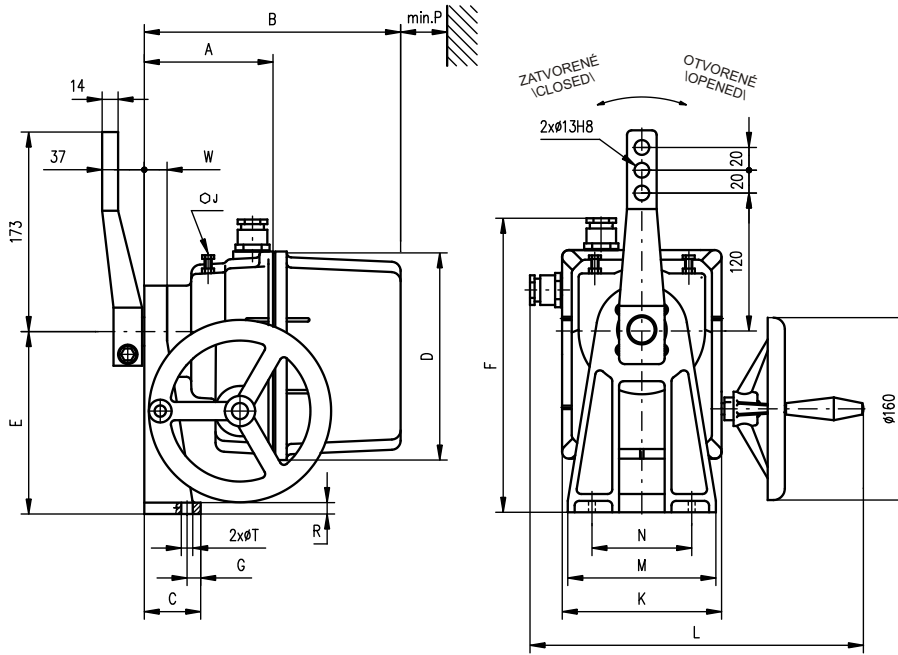

P - 1162

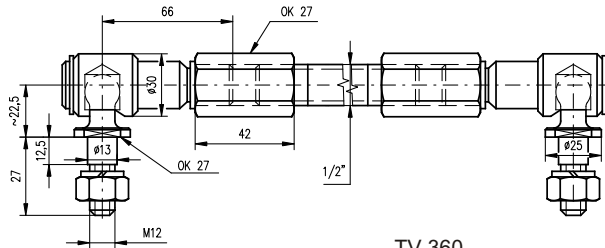

P - 0210

Tvar pripojovacieho dielca \Coupling shape\

Typ \Type\	H	S	U	V	Z	Y	Y1	Tvar pripojovacieho dielca \Coupling shape\
	SP 1	24.5	22	6	28	25	2	
SP 2	27.9	25	8	35	28	2	2	E02

Hlavné rozmery \Main dimensions\

Typ \Type\	A	B	C	D	E	E1	F	F1	F2	G	W	J	K	L	M	N	P	R	T
SP 1	122	243	50	183	160	163	258	313	273 345*	12	20	13	140	280 396*	130	80	160	10	10.5
SP 2	132	288	58	232	200	189	323	364	-	30	28	17	190	330 446*	160	90	210	11	12.6

* platí pre vyhotovenie s konektorom \valid for version with a connector\

Vyhotovenie s miestnym ovládaním \Version with local control\

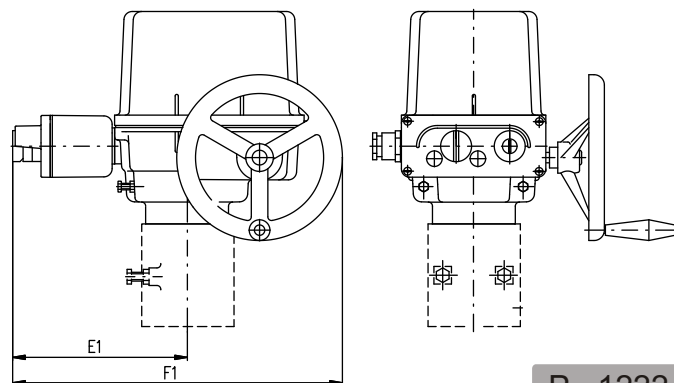

P - 1222

Vyhotovenie s miestnym ovládaním \Version with local control\

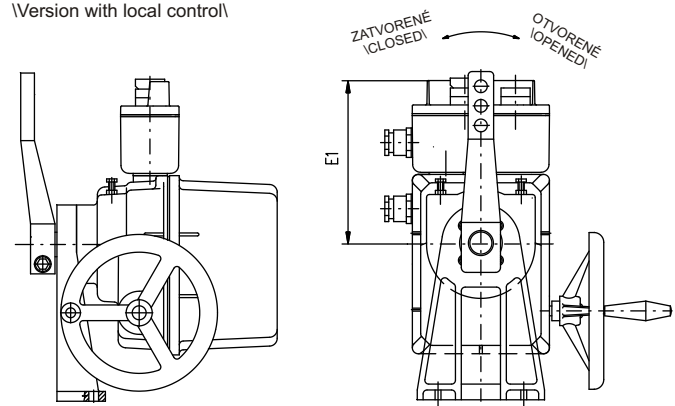

P - 1225

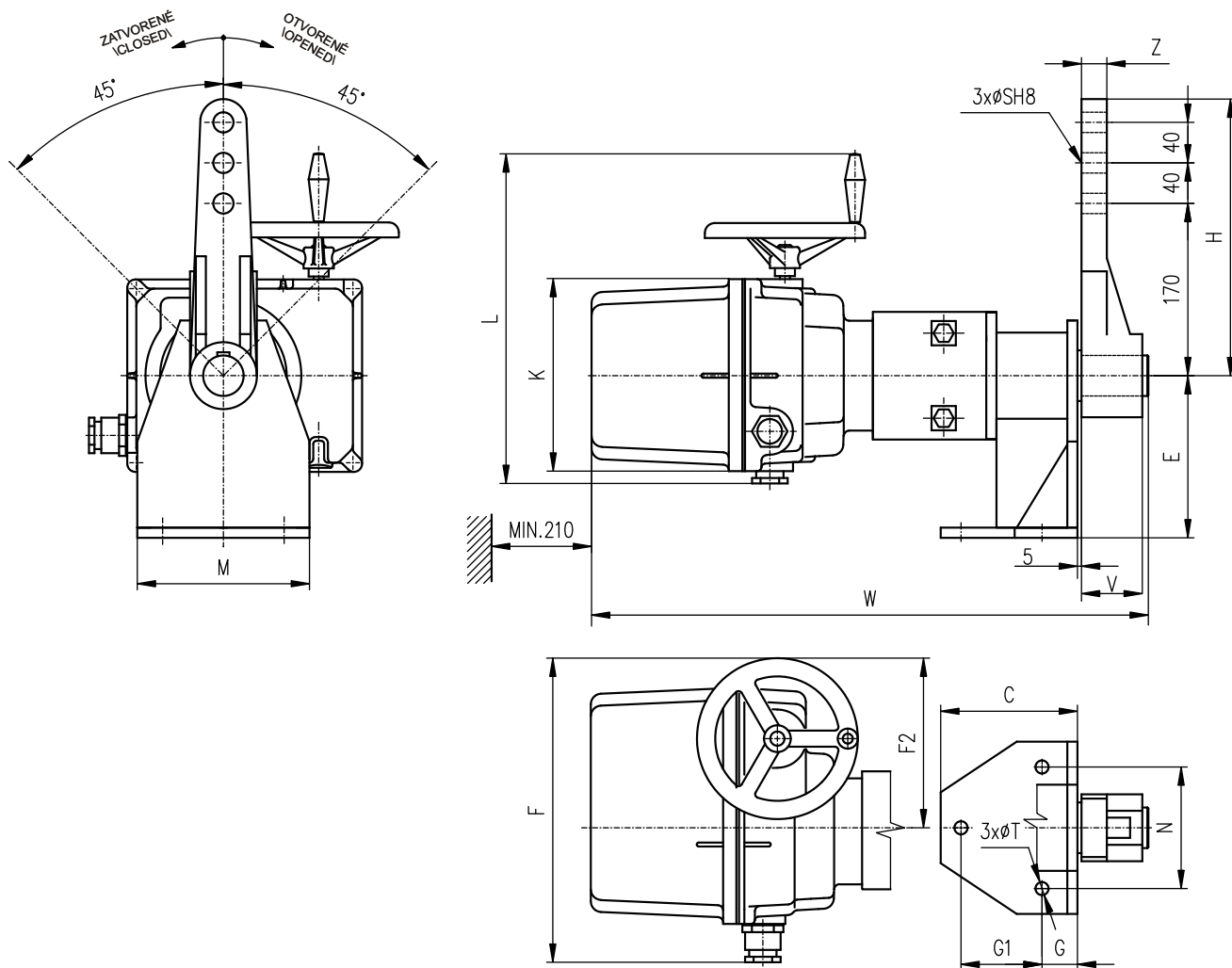

Hlavné rozmery \Main dimensions\

Typ \Type\	C	E	F	F2	G	G1	H	W	K	L	M	N	S	T	V	Z
SP 2.3	135	160	294	174	35	80	278	532	190	330 446*	170	120	20	13	56	25
SP 2.4	200	220	294	174	60	120	278	593	190	330 446*	228	170	25	17	80	30

* platí pre vyhotovenie s konektorm \valid for version with a connector\

P - 1395

Vyhotovenie pákového servopohonu SP 2.3 a SP 2.4 s miestnym ovládaním
 \Version SP 2.3, SP 2.4 with lever and local controls\

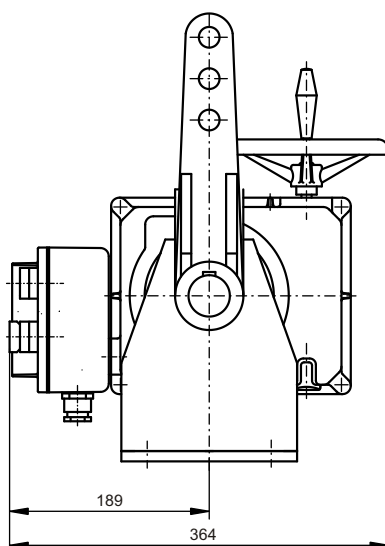

P - 1412

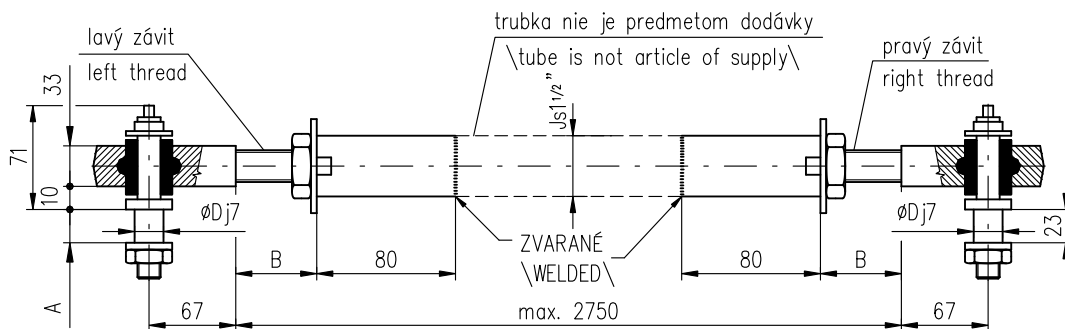

P-1413/B	SP 2.4	TV 50-1/25	28	Min.30	25
P-1413/A	SP 2.3	TV 40-1/20	23	Max.50	20
Vyhotovenie \Version\	Typ \Type\	Typ ťahadla \Pull-rod version\	A	B	D

P - 1413

Vyhotovenie servopohonu SP 2.3 a SP 2.4 so stojanom a voľným koncom hriadeľa \Version SP 2.3, SP 2.4 with stand and naked shaft\

Tvar pripojovacieho dielca \Coupling shape\

Typ \Type\	H	S	U	V	Z	Y	Y1	Tvar pripojovacieho dielca \Coupling shape\
SP 2.3	43.1	40	12	66	56	4	7	E03
SP 2.4	53.8	50	16	82	70	4	7	E04

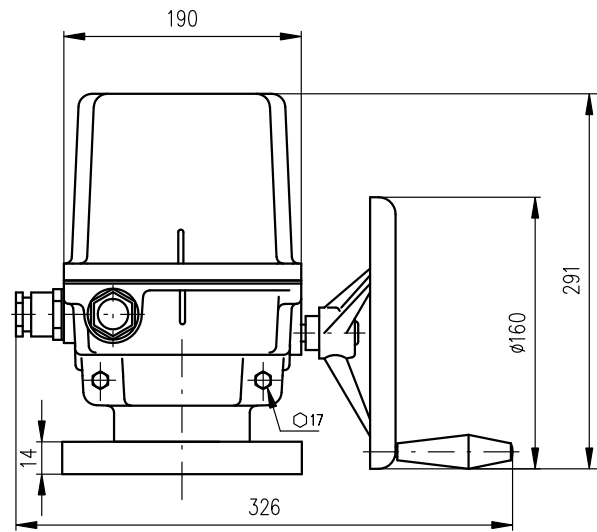
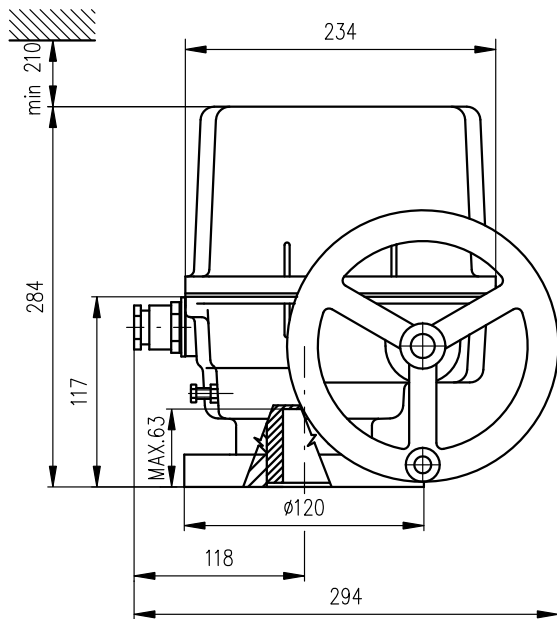

P

P

ISO 5211, F10

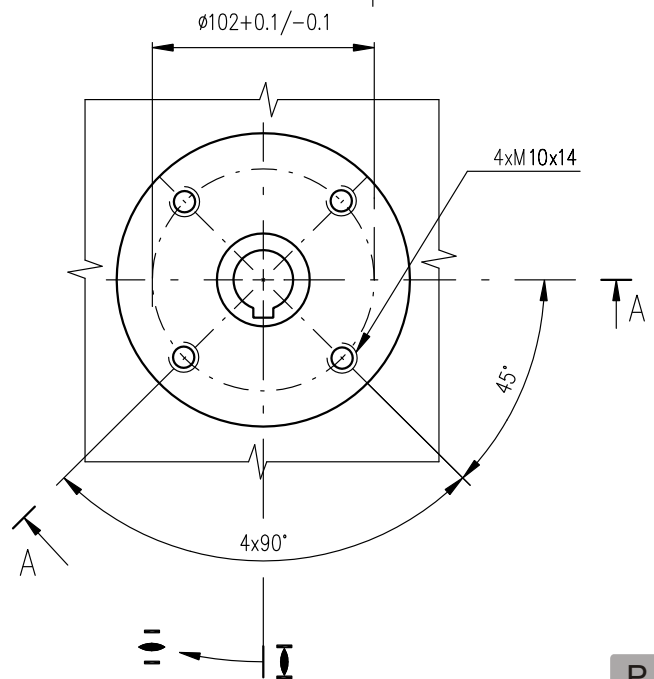
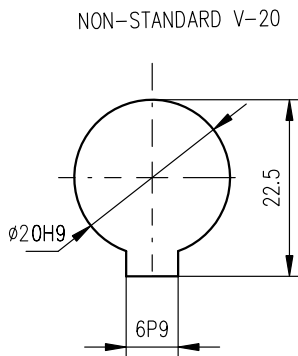
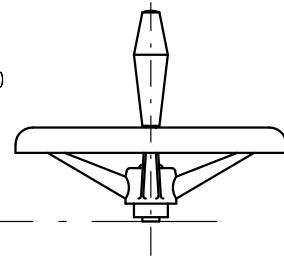

P - 2068