



INSTALLATION, SERVICE AND MAINTENANCE INSTRUCTIONS



Electric linear actuators ST 0.1, STR 0.1

TEST CERTIFICATE

ELECTRIC LINEAR ACTUATOR ST 0.1, STR 0.1

Type number 498.	Power supply V Hz
Serial number	Max. load thrust N
Production year	Set switching -off thrust N
Wiring diagram	Operating speed mm/min
.....	Stroke mm
.....	Input operation signal
Warranty period months	Transmitter
Serial number of electric motor	
Serial number of transmitter	
Serial number of position controller	
Tests made in accordance with	
Tests made by	Packed by:
Date	Signature and stamp

COMPLETENESS CERTIFICATE

Used valve

Assembled by: Firm

 Name.....

Warranty period months

Date Signature and stamp.....

INSTALLATION CERTIFICATE

Location

Installed by: Firm

 Name

Warranty period..... months

Date Signature and stamp.....

Please read these instructions carefully before mounting and operating the actuator!

Preventive and safety-measures applied on the actuator can not offer required safety level till the actuator and its safety systems are not applied by required and described way and if installation and maintenance is not applied according to applicable instructions and rules!

Contents

1.	General data.....	2
1.1	Purpose and applications	2
1.2	Safety instructions	2
1.3	Data specified on electric actuator.....	3
1.4	Warranty conditions.....	3
1.5	Under-guarantee and after-guarantee service.....	3
1.6	Operation conditions.....	4
1.7	Description.....	6
1.8	Basic specifications	7
1.9	Conservation, packing, transport, storing and unpacking	10
1.10	Appreciation of the product and packing.....	11
2.	Installation and dismantling of actuator	12
2.1	Installation	12
2.2	Dismantling.....	15
3.	Adjusting of actuator.....	16
3.1	Gear unit adjustment	16
3.2	Position unit adjustment (Fig. 6)	16
3.3	Adjustment of resistant transmitter	17
3.4	Adjustment of the Electronic Position Transmitter (EPV) - the Resistive Transmitter (Potentiometer) with the Converter PTK 1	17
3.5	Adjustment of Capacitive Transmitter CPT1/A (Fig.9)	18
3.6	Adjustment of position controller (Fig. 10)	20
4.	Service, maintenance and troubleshooting.....	22
4.1	Service.....	22
4.2	Maintenance - extent and periodicity	22
4.3	Troubleshooting.....	23
5.	Spare parts	23
6.	Enclosures.....	24
6.1	Wiring diagrams.....	24
6.2	Dimensional drawings.....	28
6.3	Guarantee service check report.....	36
6.4	Post guarantee service check report	37
6.5	Commercial representation.....	38

The Installation, Service and Maintenance Instructions are drawn up according to requirements of EC Executive Nr. 2006/42/EC "Uniform requirements for machines and devices from the point of view of safety and health care", to save life and health of users and to avoid material damages and exposure environment to danger.

1. General data

1.1 Purpose and applications

Electric linear actuators (hereinafter **EA**) of **ST 0.1** (hereinafter **ST**) or **STR 0.1** (hereinafter **STR**) types are high-powered electric-mechanical products designed for direct installations onto controlled devices (regulating bodies -valves, etc.). EA of ST types are provided for remote control of closing bodies, and EA of STR types for automotive control of regulating bodies in both directions of their movement. They can be equipped with means of measuring and control of technological processes where an unified analogue direct current or voltage signal is an information bearer on their input and/or output. They can be used in heating, energy, gas, air-conditioning and other technological systems, which they are suitable for, regarding their features. They are connected with controlled devices with a flange according to ISO 5210, or using a pillar or flange.

Note:



*Do not count with tight closing performed by control signals of EA STR.
Switching of actuator by a semiconductor switches have to be consulted with producer.
It is forbidden to use EA as a lifting mechanism!*

1.2 Safety instructions



EA of ST and STR types are reserved technical devices with higher rate of danger, with possibility of installation in areas specially danger regarding casualties caused by electric current.

Electric actuators are according to directive LVD 2006/95/EC and standard IEC 61010-1:2011 + A1:2019 assigned for installation category II (overvoltage category), pollution degree 2.

Product influence to environment

Electromagnetic compatibility (EMC): the product complies with the requirements of the Directive 2004/108/EC of the European Parliament and of the Council on the approximation of the laws the Member States relating to the electromagnetic compatibility and with the requirements of standards as well EN IEC 61000-6-4:2019, EN IEC 61000-6-2:2019, EN IEC 61000-3-2:2019 a EN 61000-3-3:2013 + A1:2019.

Vibrations caused by the product: product influence is negligible.

Noise produced by the product: The maximum allowable noise level (A) of the product measured in a place of operation is 80 dB (A).

Requirements for professional qualification of people performing installation, service and maintenance



Electric connection can be performed only by an acquainted person, i.e. an **electrical engineer** with professional education of electrical engineering at an apprentice school or a technical school (secondary, complete secondary or university education) and whose qualification was verified by an educational facility authorised to verify professional qualification.



Instructions for stuff training

Service can be performed only by workers professionally qualified and trained by the producer or contracted service centre.

Warning for safety use

Product protection:

Actuator does not have its own protection against a short-circuit therefore feeding voltage supply must include a breaker or a fuse which is also used as a master switch.

Type of equipment from a connection point of view: The equipment is designed for permanent connection.

1.3 Data specified on electric actuator

Nameplate:

REGADA	CE		IP		V	A	
⊕	TYP		№		⊕		
	kN	↔	kN		mm.min ⁻¹		mm

Warning plate:



Nameplate contains the basic data concerning identification, performance and electricity: indication of producer, type, serial number, max. load thrust and switching-off thrust, protection code, operating speed, supply voltage and current.

Graphic symbols on electric actuator

The graphic symbols used on electric actuator substitute the text messages. Some of them are in accordance with EN ISO 7010, ISO 7000 and IEC 60417 within valid edition.



Dangerous voltage

(EN ISO 7010-W012)

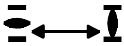

Stroke of the electric linear actuator



Switching-off thrust



Manual control

(0096 ISO 7000)



Protection terminal

(5019 IEC 60417)

1.4 Warranty conditions

The supplier is responsible for completeness of the delivery and guarantees these specifications of the product which are stated in Technical conditions (TP) or specifications agreed in the Contract.

The supplier is not responsible for any deterioration of parameters caused by the customer during storage, unauthorised installation or improper operation.

1.5 Under-guarantee and after-guarantee service

Our customers are provided with professional service of our firm in installation, operation, service, maintenance, revision and help in troubleshooting for all our products.

Trained professionals wait for you also in our contracted service centres.

Under-guarantee service is performed by the service department of the production plant, or by a contracted service centre according to a written claim.

In case of occurring of any fault please let us know it and state:

- basic data from nameplate: type code and serial number
- type of fault - description of claimed fault (actuator employment, ambient parameters (temperature, humidity...), duty cycle including frequency of switching, type of switching-off (position or thrust), set switching-off thrust)
- it is recommended to place also Installation certificate.

It is recommended to have **after-guarantee service** performed by the service department of the production plant, or by a contracted service centre.

1.5.1 Lifetime of actuators

The lifetime of an electric actuator (EA) is at least 6 years.

EA used for closing mode (closing valves) comply with the requirements for at least **15,000 working cycles** (cycle C – O – C: for linear EA).

EA used for regulating/modulating operation (control valves) comply with the below stated numbers of **operating hours** at the total number of 1 million start-ups:

Switching frequency				
max. 1,200 [h ⁻¹]	1,000 [h ⁻¹]	500 [h ⁻¹]	250 [h ⁻¹]	125 [h ⁻¹]
Minimal lifetime expectancy – number of operating hours				
850	1,000	2,000	4,000	8,000

Time of **net operation** is min. 200 hours, max. 2,000 hours.

Lifetime at operating hours depends on loading and switching frequency.

Note : High switching frequency does not ensure better regulation. Setting of regulation parameters should be therefore made with the inevitably necessary switching frequency needed for the process in question.

1.6 Operation conditions

1.6.1 Product location and operation position

EA can be installed and operated at sheltered areas of industrial plants without temperature and humidity regulation, protected against climate effects (e.g. direct sunshine). Moreover, special “marine” versions may be used in waste water treatment applications, water management, selected chemical applications, tropical environments and coastal areas.

Electric actuators must be placed with access to the manual control wheel, to the cover of control box, to control box and to bushings.

Installation and operation of actuators is possible in either position. Common position is the one with vertical position of exit part axis and control box above. Electric actuator position under the valve not recommended.



Warning:

When the EA is installed in open air, **it must be** sheltered lightly to protect is against direct effects of atmosphere.

When installed in the areas with relative humidity more than 80%, in open air under a shelter and in tropic environment it is needed to connect the space heater directly – without a thermal switch.

1.6.2 Operation Environment

According to valid standard IEC 60 721-2-1, there are delivered these versions of electric actuators:

- 1) Version „**standard**“ for type climate temperate
- 2) Version „**tropical wet**“ for type climate tropical wet
- 3) Version „**tropical dry and dry**“ for type climate tropical dry and dry
- 4) Version „**marine**“ for type climate marine

In accordance with IEC 60 364-1, IEC 60 364-5-51 and IEC 60 364-5-55 within valid edition the EA have to resist external effects and operate reliably:

In the conditions of the following types of environment:

- mild to hot dry with temperature in range -25°C to +55°C AA 7*
- with relative humidity 10 to 100 %, including the condensation of up to 0,029 kg water content per 1 kg of dry air at 27 °C, with temperatures from -25°C up to +55°C AB 7*
- with height above sea level 2 000 m, with barometric pressure range 86 to 108 kPa AC 1*
- with spraying or jet water from all directions–(protection enclosure IP x5) AD 5*
- with shallow immersion – (protection enclosure IP x 7) AD 7*
- with submersion – (product with enclosure IPx8)..... AD 8*
- with strong dustiness – with a possibility of influences of inflammable, non-conducted and non-explosive dust; the middle layer of dust; the dust drop more than 350 but not more than 1000 mg/m² per day (products with protection enclosure of IP 6x) AE 6*

- with atmospheric occurrence of corrosive and pollution media (with high degree of atmosphere corrosive aggressiveness); important presence of corrosive pollutionAF 2*
- with permanent exposure to either large quantity of corrosive or contaminating chemicals and salt mist; the version designed for marine conditions, waste water treatment plants and some chemical plantsAF 4*
- with a possibility of influences of mechanical stress:
 - medium sinusoid vibrations with frequency in range 10 up to 150 Hz, with shift amplitude of 0,075 mm for $f < f_p$ and acceleration amplitude $9,8 \text{ m/s}^2$ for $f > f_p$; (transition frequency f_p is from 57 up to 62 Hz) (applies to 2 pillars version) AH 2*
 - medium sinusoid vibrations with frequency in range 10 up to 150 Hz, with shift amplitude of 0,15 mm for $f < f_p$ and acceleration amplitude $19,6 \text{ m/s}^2$ for $f > f_p$; (transition frequency f_p is from 57 up to 62 Hz) (applies to 4 pillars version) AH 2*
 - medium impacts, shocks and vibrations AG 2*
- with serious danger of plants and moulds growing AK 2*
- with serious danger of animals occurrence (insects, birds, small animals) AL 2*
- with detrimental influence of radiation:
 - of stray current with intensity of magnetic field (direct and alternating of power supply frequency) to 400 A.m^{-1} AM 2-2*
 - of sun radiation with intensity $> 500 \text{ a} \leq 700 \text{ W/m}^2$ AN 2*
- with effects of medium seismic activity with acceleration $> 300 \text{ Gal} \leq 600 \text{ Gal}$ AP 3*
- with indirect danger of storm activity AQ 2*
- with fast moving of air and strong winds AR 3 , AS 3*
- with persons frequent touching earth potential (persons often touch conductive parts or they stand on the conductive basement) BC 3*
- without any danger media with object BE 1*

* Marking in accordance with IEC 60 364-1, IEC 60 364-5-51, IEC 60 364-5-55 within valid edition).

1.6.3 Power supply and duty cycle

Power supply:

electric motor	230/220 V AC $\pm 10\%$, 24 V AC/ DC $\pm 10\%$, resp. 3x400/3x380V AC $\pm 10\%$
control	230/220 V AC $\pm 10\%$, resp. 24 V AC/DC $\pm 10\%$
potentiometer	$\max. \sqrt{P \times R} \text{ V DC/AC}$
capacitive transmitter without power supply (AC).....	18 up to 28 V DC
electronic positional transmitter without power supply	15 up to 30 V DC, or 24 V DC

Power supply frequency 50 Hz or 60 Hz $\pm 2\%$

Note: At frequency of 60 Hz operating speed is reduced by 1.2 times.

Duty cycle (according to IEC 60034-1, 8):

EA ST are designed for **remote control**:

- short-time operation **S2-10 min**
- intermitted operation **S4-25%, 6 up to 90 cycles per hour**

EA STR are designed for **automatic regulation**:

- intermitted operation **S4-25%, 90 up to 1200 cycles per hour**

Note: EA ST 0.1 is possible connect with external controller and use it as regulated EA and for this EA stand duty cycle and power parameters like for type STR 0.1 with built-in controller. For EA with controller we do not suggest operating speed 63 mm per min.

1.7 Description

The actuators are wired in accordance with the wiring diagram put into the upper cover. Electric and mechanic connections are performed according to the Mounting Instructions. The actuator output part (stem) provides linear movement in the direction "opening" and in the direction "closing". The movement in the direction "opening" is available with receiving of electric pulses on the terminals 1 and 12. The movement in the direction "closing" is arranged with receiving of electric pulses on the terminals 1 and 16. The actuator is driven with the electric motor (1) fed and controlled through two switches (2). The switches are switched with a finger (5). The position switches (3) are switched with the cams (4). The space heater (6) and the thermal switch (7) are located on the control board. In accordance with the order the potentiometer (8) is also placed in the control part to be used as a resistive feedback or as a remote position transmitter. In case of mains failure or damages of switches the actuator can be operated also manually in accordance with instructions given in the Chapter 4.3 Operation.

The **STR** version is equipped with an **electronic controller**.

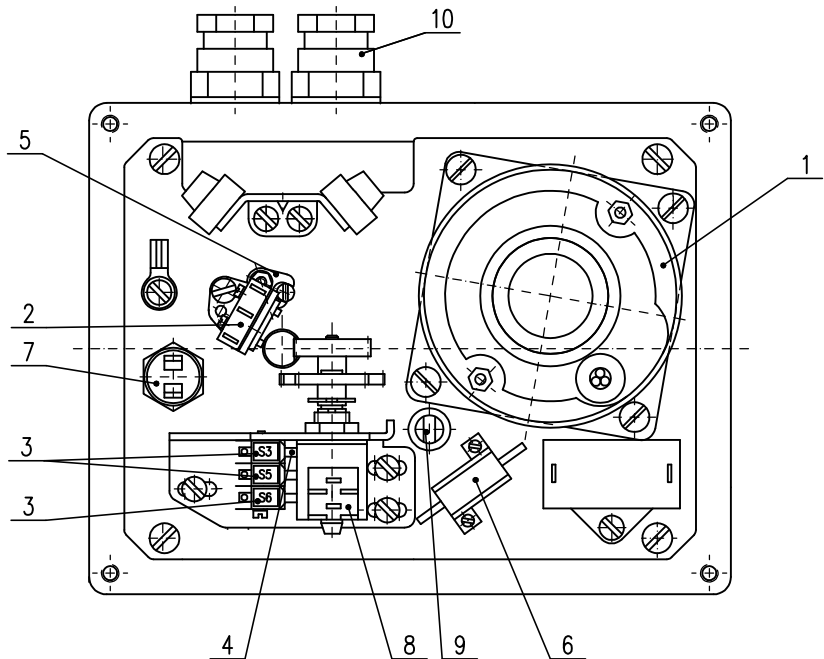

Fig.1

1.8 Basic specifications

1.8.1 Basic EA specifications:

Max. load thrust [N], operating speed [mm/min], operating stroke [mm] and electric motor parameters are given in Table 1.

Table 1: Basic Specifications

Type Number	Operating speed ±10% ²⁾	Operating stroke	Max. load thrust for STR	Max. load thrust	Switch-off Thrust ±10%	Weight	Electric motor ¹⁾								
							Power supply nominal voltage.	Nominal						Capacitor capacity	
								power		speed		current for			
								230/220 V AC (3x400/ 3x380 V AC)	24 V AC (DC)	230/220 V AC (3x400/ 3x380 V AC)	24V AC (DC)	230/220 V AC (3x400/ 3x380 V AC)	24V AC (DC)		230/220 V AC
[mm/min]	[mm]	[N]	[N]	[N]	[kg]	[V] ±10%	[W]	[1/min]	[A]	[µF/V]					
1	2	3	4	5	6	7	8	9	10	11	12	13	14	15	16
ST 0.1 / STR 0.1, type number 498	10	10; 12,5; 16; 20; 25; 32; 40; 50 12-13; 14-15; 17-18; 19-20; 22-24; 25-28; 29-32	2600	3200	3600	ST: 5,4 – 7,6; STR: 5,8 - 8	Single - phase 230/220 V	direct current 24 V AC or 24 V DC	15	20	2750	3200	0,30	1,8	2,2
	16														
	25														
	32														
	40														
	63 ³⁾														
	10														
	16														
	25														
	32														
	40														
	10														
	16														
	25														
	32														
	40														

1) Switching elements for different type of load (also for EA) defines standard IEC 60 947-4-1.

2) Anomaly of operating speed: -15% at temperatures under -10°C
 ± 10% at 230/220 V (or 3x400/3x380 V) AC
 -50 up to +30% in dependence on load at 24 V AC/DC.

3) Valid for version without any cotroller.

Protection enclosure of EA: IP 65, IP 67, IP 68 IEC 60 529 within valid edition
 According to definition for EA, enclosure IP68 fulfills following requirements:

- water column max. 10m
- time of continious submersion in water max. 96 hours.

Mechanical ruggedness:

- sinusoid vibrations see chapter 1.5.2
- drop resistance: 300 drops with acceleration 5 m.s⁻²
- seismic resistance: amplitude of the shock off 6 on Richter scale

Self-locking: guaranteed within 0% till 100% load thrust

Position transmitters

Resistive – potentiometer:

- Resistance single (B1): 100 Ω, 2000 Ω
- Resistance double (B2): 2x100 Ω, 2x2000 Ω
- Operating life of transmitter 10⁶ cycles
- Load capacity: 0,5 W up to 40°C (0 W/125°C)

Maximum current of sliding contact	max. 35 mA
Maximum supply voltage:.....	$\sqrt{P \times R}$ V DC/AC
Potentiometer linearity error:	± 2 [%] ¹⁾
Potentiometer hysteresis:	max. 1.5 [%] ¹⁾
Output signal values measured on clamps 71 and 73 at limit positions	
For ST: "O" (open).....	$\geq 93\%$, "Z" (closed)
For STR: "O" (open).....	$\geq 85\%$ and $\leq 95\%$, "Z" (closed) $\geq 3\%$ and $\leq 7\%$

Capacitive (B3): non-contact, life 10^8 cycles

2-wire connection with power supply or without power supply

The current signal **4 ÷ 20 mA** (DC) is acquired from the capacitive transmitter supplied from the internal or an external voltage supply source. The electronics of the transmitter is protected against eventual wrong polarity and current overloading. The entire transmitter is galvanic insulated so several transmitters can be connected to one external voltage source.

Power supply voltage (with power supply)	24 V DC
Power supply voltage (without power supply)	18 to 28 V DC
Ripple voltage	max. 5%
Max power input	0,6 W
Load resistance 0 to 500 Ω	
Load resistance can be single side grounded.	
Influence of resistance on output current	0,02%/100 Ω
Influence of voltage on output current	0,02%/1V
Temperature dependency	0.5% / 10 °C
Output signal values at limit positions:	"O".... 20 mA (clamps 81,82)
.....	"Z"..... 4 mA (clamps 81,82)
Values tolerance of output signal of capacitive transmitter	"Z" +0,2 mA
.....	"O" $\pm 0,1$ mA

Electronic positional transmitter (EPV) - converter R/I (B3)

a) 2-wire version - without built-in power supply, or with built-in power supply

Current signal	4 ÷ 20 mA (DC)
Power supply voltage	15 ÷ 30 V DC
Load resistance (at version without build-in power supply)	max. $R_L = (U_n - 9V) / 0,02A$ [Ω]
.....	(U_n - power supply voltage [V])
Load resistance (at version with build-in power supply)	max. $R_L = 750 \Omega$
Temperature dependency	max. 0,020 mA / 10 K
Output signal values at limit positions:	"O".... 20 mA (clamps 81,82)
.....	"Z"..... 4 mA (clamps 81,82)
Values tolerance of output signal of EPV	"Z" +0,2 mA
.....	"O" $\pm 0,1$ mA

b) 3-wire version - without built-in power supply, or with built-in power supply

Current signal	0 ÷ 20 mA (DC)
Current signal	4 ÷ 20 mA (DC)
Current signal	0 ÷ 5 mA (DC)
Power supply voltage (at version without built-in power supply)	24 V DC $\pm 1,5\%$
Load resistance	max. 3 k Ω
Temperature dependency	max. 0,020 mA / 10 K
Output signal values at limit positions:	"O".... 20 mA or 5 mA (clamps 81,82)
.....	"Z"..... 0 mA or 4 mA (clamps 81,82)
Values tolerance of output signal of EPV and capacitive transmitter	"Z" +0,2 mA
.....	"O" $\pm 0,1$ mA

EPV and capacitive transmitter linearity error:	± 2 % ¹⁾
EPV and capacitive transmitter hysteresis:	max. 1.5 % ¹⁾

¹⁾ from rated value of transmitter referred to output values

Electronic position controller (N)

Controller software equipment:

A) Function and parameters

programmable **functions**:

- ..with functional buttons SW1, SW2 and LED diodes D1, D4 directly placed on controller
- ..with computer or terminal equipped with corresponding programme, using RS 232 interface.

programmable **parameters**:

- ..control signal
- ..response to SYS-TEST signal
- ..mirroring (ascending/descending characteristics)
- ..insensitiveness
- ..EA limit positions (only with computer and ZP2 programme)
- ..way of regulation

B) Operation states of controller

Error message from error memory: (using LED diodes and RS 232 and personal computer)

- ..control signal missing or faulty
- .. input value of current control signal under 3.5 mA
- ..existence of SYS-TEST signal
- ..activity of switches
- ..failure of feedback position transmitter

Statistic data: (using RS 232 and personal computer)

- ..number of controller operation hours
- ..frequency of relay switching in direction "opening"
- ..frequency of relay switching in direction "closing"

Supply voltage: terminal 61 (L1) -1(N) – 230/220 V AC, $\pm 10\%$
resp. terminal 61 (+) -1(-) - 24V DC, $\pm 10\%$

Frequency: 50/60 Hz $\pm 2\%$

Input control signals - analogue: 0 - 20 mA

..... 4 - 20 mA

..... 0 - 10 V

Input resistance for signal 0/4 - 20 mA 250 Ω

Input resistance for signal 0/2 - 10 V 50k Ω

(Actuator opens at rising of control signal.)

Controller linearity: 0.5 %

Controller insensitiveness: 1 - 10% (adjustable)

Feedback (position transmitter): resistive 100 up to 10,000 Ω

..... current 4 up to 20 mA

Power outputs: 2x relay 5A/250 V AC

Digital outputs:4x LED (supply, error, adjustment, "opening", "closing" - with two-colour LED)

Error status: control switch 24 V, 2W - POR

Reaction at error situation: transmitter error - error message LED

Control signal missing: error message LED

SYS mode: error message LED

Adjusters: communication connector

..... 2x calibrating and adjusting button

Switching-off:

Switching-off voltage: 250 V(AC); 50/60 Hz; 2 A; $\cos \varphi=0.8$; or 250V(DC); 0,1 A,

..... or 24 V (AC/DC); 2 A; T=L/R=3ms

Space heater

Space heater - supply voltage: corresponding with motor supply voltage (max. 250 V AC)

Space heater power output: .. max. 10 W/55°C

Thermal switch of space heater

Supply voltage: corresponding with motor supply voltage (max. 250V AC, 5 A)

Switching-on temperature: +20°C ± 3K

Switching-off temperature: +30°C ± 4K

Manual control: with handle;
rotating clockwise (counter-clockwise) EA output part is moving in direction "Z" ("O")

Electric control:

remote control (output motion of actuator is operated by power supply voltage)

Output part backlash: max. 0,5 mm (at 5% of max. load thrust)

Adjustment of limit positions:

Limit position switches are adjusted with accuracy ± 0,5 mm referring to lower position and stroke.

Additional position switches are adjusted 1mm before end positions.

Weight: ST 6,3 – 9,5 kg

1.8.2 Mechanical connection

- flange
- pillars

Basic and connecting dimensions are given in dimensional drawings

1.8.3 Electric connection

- **with terminal board (X):** . max. 23 terminals, conductor cross-section; max. 2,5mm²
- 3 cable glands: 1xM20x1,5 - connection of cables 8 up to 14,5 mm and 2x M16x1,5 - connection of cables 6 up to 10,5 mm. When using two types of extended cable glands - connection of cables 9 to 13 mm (max for 2 positions, without combination with cable glands from 14 to 18 mm), resp. from 14 to 18 mm (just for one position).
- **with protection terminal:**
external and internal, mutually connected and marked with protection earthing mark

Electric connection - according to wiring diagrams.

1.9 Conservation, packing, transport, storing and unpacking

Surfaces without surface treatment are treated by conservation preparation MOGUL LV 2-3 before packaging .

Conservation is not necessary if the following storage conditions are complied with:

- Storage temperature: -10 to +50 °C
- Relative air humidity max.80 %
- Electric actuators and their accessories must be stored in dry, well ventilated covered spaces, protected against impurities, dust, soil humidity (by placement to racks, or on palletes), chemicals and foreign interventions
- There shall be no corrosive gases present in the storage areas.

The EA are delivered in solid packages guaranteeing resistance in accordance with EN 60 654 (IEC 60 654-1 and IEC 60 654-3).

Package is a box. Products in boxes is possible to load on the pallets (pallet is returnable). On the outer side of the package is stated:

- manufacturer label,
- name and type of product,
- number of pieces,
- other data – notices and stickers.

The forwarder is obliged to secure packed products, loaded on transportation means, against self-motion; if open transportation means are used, to secure their protection against atmospheric precipitations and splashing water. Displacement and securing of products in transportation means must provide their stable position, exclude the possibility of their inter-collision and their collision with the vehicle walls.

They can be transported in unheated and not airtight areas of transport means with effects in range:

temperature: -25°C up to +70°C

humidity: 5 up to 100%, with maximal content of water 0.029 kg/kg per kg of dry air

barometric pressure: 86kPa up to 108kPa

After receiving EA check whether during transport or storage the actuator was not damaged. Compare also whether the parameters on their nameplates are in accordance with accompanying documentation or the Contract. If any discrepancy or fault occur inform immediately your supplier.



If the actuators and accessories are not immediately installed, they have to be stored in dry, well-ventilated sheltered roos, protected against dirt, dust, soil humidity (with placing onto shelves or onto pallets), chemical impacts and encroachment, at ambient temperature from -10°C up to +50 °C and relative humidity max. 80 %.

It is not allowed to store EA in the open air or in areas not protected against direct impact of climate!

If any scratch on the surface finishing occurs remove it immediately - you protect this way actuators against damaging with corrosion.

If storing takes longer than 1 year, it is necessary to inspect lubrication fillings before putting EA into operation.

Assembled EA, but not put into operation is necessary to protect by the equivalent method as during storage (for example suitable protective cover).

After assembly to the armature in free and wet areas, or in areas with temperature changes, connect without delay heating resistor – thus preventing damages caused by corrosion from liquefied water in the control area.

Excessive preserving grease remove just before putting EA into operation.

1.10 Appreciation of the product and packing

The product and its package are made of recycling materials. Do not throw the single parts of the package and of the product after their life but sort them according to instructions in corresponding executives or regulations of environment protection, and allow their recycling.

The product and its packing are not a source of any environment pollution or contamination and do not contain any dangerous waste.

2. Installation and dismantling of actuator



Abide by safety measures!

Before starting of mounting the EA onto the valve:

- Check again whether the EA was not damaged during storing.
- Check whether the adjusted operating stroke and connecting dimensions of the actuator (see the nameplate) are in compliance with the valve parameters.
- In case of inconsonance, perform adjusting according to the part Adjustment.

2.1 Installation

EA is by the producer adjusted to parameters according to the nameplate, with connecting dimensions according to the corresponding dimensional drawing and put it to a mid-position.

Before installation put the handle on.

2.1.1 Mechanical connection

The actuators can be installed and operated in any position. While installing leave enough space for dismantling of the upper cover to allow adjusting of the control parts.

Mechanical connection with connection dimensions according to ISO (DIN) Standards (Fig. 2)

Connection procedure:

- Check the labels whether valve and actuator strokes are the same.
- Set the actuator (A) and the valve (B) to the position "closed".
- Put the actuator (A) onto the valve (B).
- Screw the actuator output shaft (2) into the valve coupling (6) until the actuator flange reaches the valve upper body (7).
- Tighten the screws (3) to fasten the actuator flange (1) with the valve upper body (7).
- Check connection dimensions in accordance with dimensional drawing P-1201.
- Turn the valve output shaft by one revolution and lock it with the nut (5).

A..... electric actuator
 1 actuator flange
 2 actuator output shaft
 3 screw

B..... valve
 4 valve output shaft
 5 lock nut
 6 valve coupling
 7 valve upper body

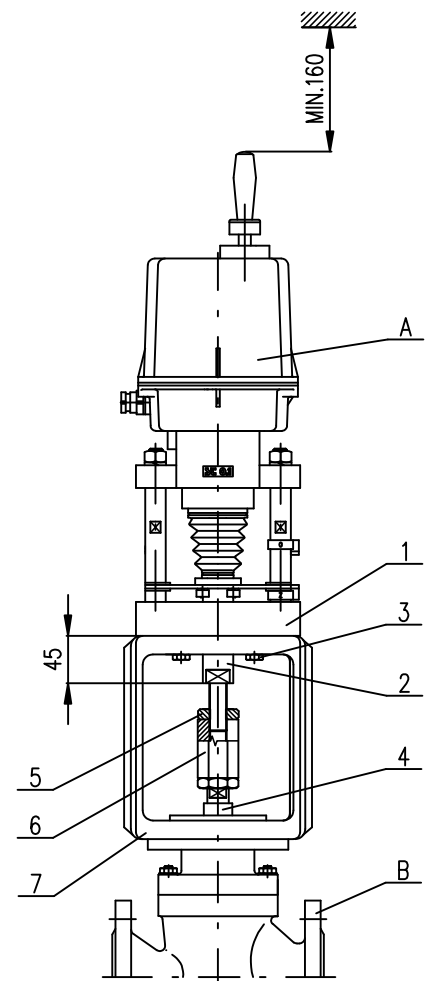

Fig.2

Mechanical connection for pillar version - Fig. 3

Connection procedure:

- Check the label whether valve and actuator strokes are the same.
- Put the valve (B) to the position "closed" and the actuator (A) to a mid-position.
- Loosen the screws (2) located on the pillars (4).
- Screw alternatively the pillars (4) into the valve flange (8).
- Fasten the pillar nuts (2).
- Unscrew the coupling screws (3) to dismantle the coupling.
- Screw the coupling nut (1) onto the valve shaft (6) to reach the connection dimension H in accordance with the Table and the actuator label.
- Unscrew the coupling nut (1) by one revolution and lock it with a nut. (7).
- Use the handle (5) to have the actuator output shaft close to the valve shaft (6) and screw the coupling parts together.

- A..... electric actuator
 1 coupling nut
 2 pillar nut
 3 coupling screw
 4 pillar
 5 handle for manual control
- B..... valve
 6 valve shaft
 7 lock nut
 8 valve flange

Order number	H
498.X-XXXXP	110
498.X-XXXXN	57
498.X-XXXXM	27
498.X-XXXXL	80
498.X-XXXXK	42
498.X-XXXXJ	127

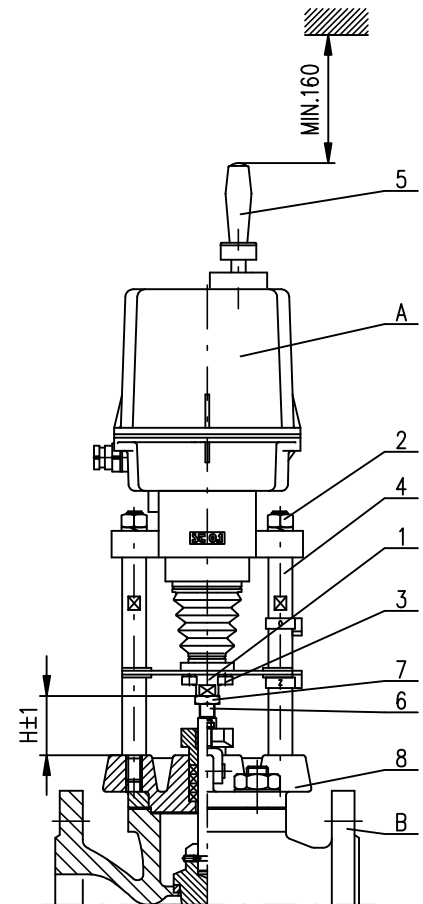

Fig. 3

Mechanical connection for versions with flange (Fig. 4)

Connection procedure:

- Check the labels whether the actuator and the valve strokes are the same.
- Set the actuator (A) to a mid-position and the valve (B) to the position "closed".
- Put the actuator (B) onto the valve (A).
- Screw the coupling nut (1) onto the valve output shaft (3) until the actuator shaft (2) contacts the valve flange (4).
- Connect the flanges with tightening of the central nut (5).
- Check the connection dimension H between the coupling and the flange (2) in accordance with the Table and the type Nr. in accordance with the actuator label.
- Unscrew the coupling nut (1) by one more revolution to the left and lock with the nut (6) to create the prestress onto the valve seat.
- Use the handle to have the actuator output shaft close to the valve shaft (3) and screw the coupling parts together.

- A.....electric actuator
 1coupling screw
 2actuator flange
- B.....valve
 3valve shaft
 4valve flange
 5central nut
 6lock nut

Order number	H
498.X-XXXXF	102
498.X-XXXXE	92
498.X-XXXXD	112
498.X-XXXXC	110
498.X-XXXXB	103

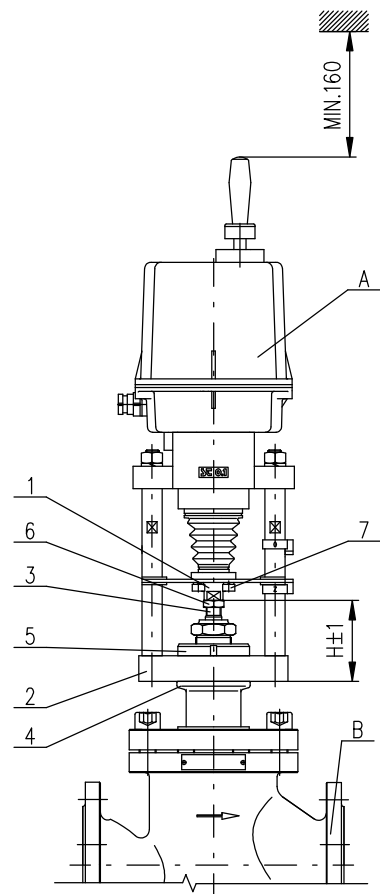

Fig.4

Mechanical connection for versions with flange (Fig. 5)

Connection procedure:

- Check the labels whether the actuator and the valve strokes are the same.
- Put the valve (B) to the position "closed" and the actuator (A) to a mid-position.
- Screw up and remove from the actuators flange (7) screws M8x50 (6).
- The actuator with flange (A) put onto the valve (B).
- Screw alternatively screws M8x50 (6) to lock the actuator and valve connection.
- Unscrew the coupling screws (3) to dismantle the coupling.
- Loosed holder of coupling (1) put onto valve shaft (8) in this way that it was possible to plug-in segments (2) into groove of valve shaft.
- Put onto segments (2) and stop tube (4).
- Use the handle (5) to have the actuator output shaft close to the valve shaft (8) and screw the coupling parts together.
- Check correctness of mechanical connection using the handle (5).
- Follow up with electric connection of EA according to wiring diagram placed in top cover of actuator.
- After electric connection perform checking of function.

- A actuator
 1 holder of coupling
 2 coupling segment
 3 coupling screw
 4 stop tube
 5 handle
 6 flange screw
 7 actuator flange
- B valve
 8 valve shaft

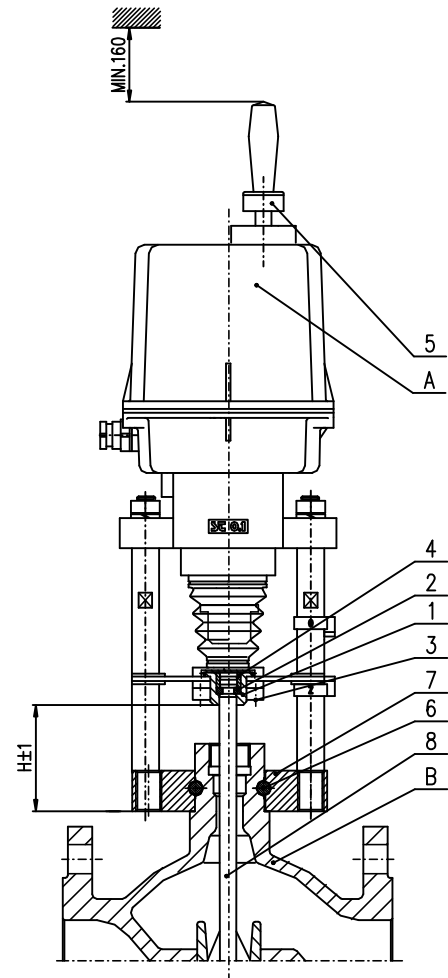

Fig. 5

2.1.2 Electric connection and checking of function

1. Follow instructions in the part "Requirements for professional qualification"!
2. While laying electrical line abide by the instructions for heavy current installations.
3. Cables to terminal boards or connectors lead through screw bushings. The cable jacket diameters must conform to the extent specified in Chapter 1.8.3!
4. Before initiation EA into operation internal and external protection terminals are needed to be connected.
5. The EA are delivered with bushings which in case of correct tighten are onto the supply lead allow the protection enclosure of IP 68. To arrange the enclosure it is needed to use seal rings according to the actual size of cable and the required temperature.
6. The cable is to be fixed the way corresponding with its allowable bending radius not to damage or deform the sealing element of the cable lead. The supply leads have to be fixed onto a fixed construction max. 150 mm from the leads.
7. It is recommended to connect the remote transmitters with shielded wires.
8. The face areas of the control part cover should be clean before fixing it back.
9. The EA is reversible if the time interval between the power supply is switched off and on for the reverse direction of the output part motion is at least 50 ms.



10. The allowed delay after it is switched off, i.e. time from the switches reaction up to the motor without any voltage is 20 ms maximally.

11. If the EA is controlled with an external controller using unified signal from a two-wire transmitter (capacitive or resistive with a converter in two-wire connection), it is needed to arrange connecting of the two-wire transmitter loop to electrical earth of the successive external controller!. Connection can be performed only in one point, in any part of loop out of the EA.

12. Electronics of the two-wire transmitters is galvanically insulated that is why it can serve as an external source for supplying of several transmitters (their number depends on current which the source can supply).

13. To prevent moisture from entering the actuator around the connecting cables, the cables must be sealed with silicone material at the point of penetration through device shell.

Connecting with the master system:

The EA can be controlled with:

- a built-in position controller
- an external position controller

After electric connection it is recommended:

Check of wiring. Set the actuator into a mid-position. Check the right direction of output shaft movement with pressing the button "closing" (on the control board) and the stem should move out from the actuator. If not you check proper connection.

Check the control unit switches wiring with switching consequently the contacts of the proper switches by pressing the control elements during the motion of the actuator (at proper connection) to the chosen direction. In case of correct wiring of the switches, the actuator stops or indicates the set position according to switching of the chosen switch. If any of the functions is fault check wiring of the switches according to the wiring diagram.



In the **STR version** with the built-in electronic controller it is needed to perform **autocalibration** for assuring optimal functioning.

The procedure is as follows

Press the button **SW1** for about 2 sec (i.e. till the **D3** diode is got on) to set the controller to the **autocalibration** mode. During this process the controller checks the feedback transmitter and the sense of turning, puts the EA to the positions open and closed, measures inertia mass in the directions "opening" and "closing", and loads the adjusted parameters into the EEPROM memory. In case that during the initialisation process an error occurs (e.g. in connection or adjustment) the initialisation process will be interrupted and the controller with the **D4** diode reports about the type of the error. Else after finishing the initialisation process the controller is put into the **regulation mode**. If needed to change adjusted parameters of the controller follow instructions given in the part Adjusting of actuator.

2.2 Dismantling



**Before dismantling it is required to disconnect the EA from mains!
Do not connect and disconnect live connectors!**

- Disconnect the EA from mains phases.
- Disconnect the leads from the EA terminal boards and loosen the cables from bushings.
- Loosen the fixing screws of the EA flange and of the coupling and disconnect the EA from the valve.
- While sending the EA to be repaired put it into a package solid enough to avoid damages of the EA during transportation.

3. Adjusting of actuator



Abide by safety measures!

The adjustment can be performed at a mechanically and electrically connected EA. This part describes adjustment of EA to specified parameters in case that any unit of EA is reset.

Laying of adjusters of the control board is shown on Fig.1.

3.1 Gear unit adjustment

The switching thrust values both for the direction "opening" (the thrust switch S1) and for the direction "closing" (the thrust switch S2) are in the production plant adjusted to the rated thrust with tolerance $\pm 10\%$. The numeric values are given in the table 1. Adjustment and resetting of the gear unit to other thrust values are not possible without having a special test device to measure thrust values.

Attention!

For assembling with mono-seating valve the actuator must be connected as single-thrust switching, i.e. by serial prefixing of positional switch S3 before force switch S1 (open) (the switch S1 provides only protection function).

The positional switch is adjusted by the producer to the upper limit of the operation stroke. The serial prefixing is arranged with mutual connection of "19" and "12" terminals on the actuator's terminal board. In the case it is necessary to feed the "1" and "20" terminals for the direction "open".

3.2 Position unit adjustment (Fig. 6)

The actuator is in the plant adjusted

a) in case of the actuator with independent strokes:

- the position switch (1) - S3 "open" to the stroke in accordance with the correspondent catalogue sheet,
- the additional position switch (2) - S5 ca 1 mm before the limit position "open" (with the position switch (1) - S3),
- the position switch (3) - S6 ca 1mm before the limit position "closed".

b) in case of the combined stroke range:

- the position switch (1) - S3 "open" to the maximal stroke of the joined range in accordance with the actuator label,
- the additional position switch (3) - S5 ca 1mm before the limit position "open" (with the position switch (1) - S3),
- the additional position switch (3) - S6 ca 1mm before the limit position "closed".

While adjusting of the position unit follow these steps:

- Put the actuator to the limit position "open", put the screwdriver into the cam groove (4) or (5) and turn the cam clockwise until the micro-switch (1) or (2) switches.
- Put the actuator with the actuated device with the manual control mechanism by the fixed operation stroke to the position "closed" and put the screwdriver into the cam groove (6) and turn counter-clockwise till the switch (3) is switched.
- Check the adjustment and in case of not valid switching-off repeat the procedure.

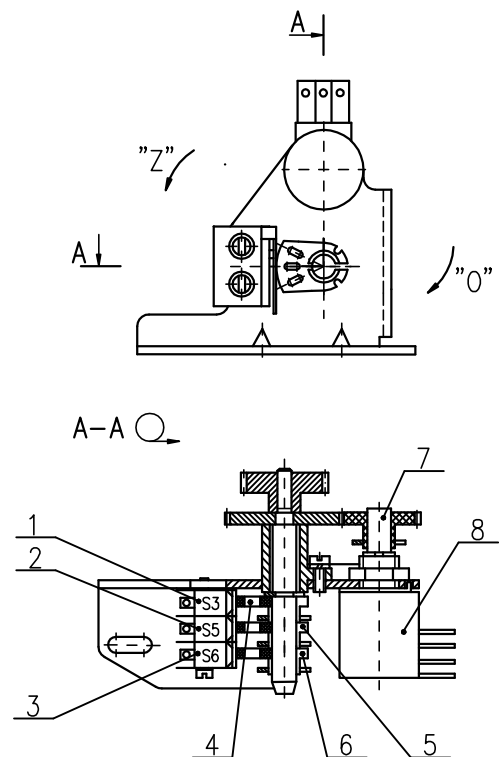

Fig.6

3.3 Adjustment of resistant transmitter

The **resistant transmitter** is in the EA **ST** used to function as a remote position indicator; in the EA **STR** to function as a feedback in the position controller and if needed also in the position of a remote resistant position indicator.

Before the resistant transmitter adjustment the position switches have to be adjusted. The transmitter cannot be adjusted to another operating stroke as stated on the nameplate of the actuator. Adjustment consists in setting of the resistance in the defined limit position of the EA.

Notes:

1. In case that the EA is not used in the whole stroke range given on the nameplate, the resistance in the limit position "open" is proportionally reduced.
2. In the EA **STR** 2000W resistant transmitters are used. In the other cases if the resistant branch is lead to the terminal board the resistance of the transmitters is according to the customer's specification.

In the plant the transmitter (8) is adjusted to:

a) in case of versions with independent strokes to have resistance on the terminals 71 and 73 in the limit position "closed" 5% of the whole resistance of the transmitter, and in the position "open" 93% of the whole resistance of the transmitter.

b) in case of the version with combined stroke range to have resistance on the terminals 71 and 73 in the limit position "closed" 5%, and in the position "open" 85% of the whole resistance of the transmitter.

In case the transmitter is needed to be adjusted follow these steps:

- Put the actuator to the position "closed".
- Connect a meter for resistance measuring to the terminals 71 and 73 of the EA **ST** terminal board, or to the terminals 6 and 7 of the controller of the EA **STR**.
- Rotate the transmitter shaft until resistance $\leq 5\%$ of the nominal transmitter resistance can be read on the meter in case of EA **ST**, and 3 up to 7% of the nominal transmitter resistance in case of EA **STR**, or in case of EA **ST** with EPV, i.e. with the resistant transmitter with the converter PTK 1.
- Resistance in the position "open" is arranged by the gear mechanism.

3.4 Adjustment of the Electronic Position Transmitter (EPV) - the Resistive Transmitter (Potentiometer) with the Converter PTK 1

3.4.1 EPV – the 2-wire version (Fig. 7)

The position transmitter with the converter PTK1 is in the plant adjusted to have the output current signal on the terminals 81-82 (the wiring diagram Z23, or Z269 with a power supply) as follows:

- in the position "open" 20 mA
- in the position "closed" 4 mA

If the transmitter requires a new adjustment follow these steps:

- Put the actuator to the position "closed" and switch the power supply off.
- Adjust the resistive transmitter according to the previous chapter. The resistance is to be metered on the terminals X-Y (Fig. 7). The used transmitter resistance is 100 W.
- Switch the converter's power supply on.
- Turn the adjusting trimmer ZERO (Fig. 7) to adjust the output current signal rate measured on the terminals 81-82 to 4mA.
- Set the actuator to the position "open".
- Turn the adjusting trimmer GAIN (Fig. 7) to adjust the output current signal rate measured on the terminals 81-82 to 20mA.
- Check the output signal of the converter in the both limit positions, and repeat the procedure if needed.

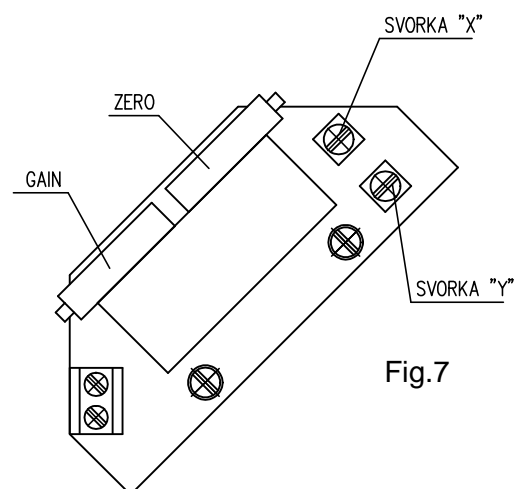

Fig.7

Note:

The output signal of 4-20mA can be adjusted at the range from 75 up to 100% of the rated stroke stated on the actuator's nameplate. At values less than 75% the value 20mA is reduced proportionally.

Adjustment of the EPV in Electric Actuators SPR with controllers

- Disconnect the circuit with removing a jumper on the terminals 81 and 82.
- Disconnect the control signal from the terminals 86/87 and 88.
- Set the actuator to the direction "OPENING" or "CLOSING" with the handwheel, or with connecting power to the terminals 1 and 20 for the direction "OPENING" or 1 and 24 for the direction "CLOSING".
- Set the actuator to the position "CLOSING" and switch the converter off on the terminals 1 a 61.
- Adjust the resistive transmitter according to the previous chapter. The resistance is to be metered on the terminals X-Y (Fig. 7).
- Connect power supply to the terminals 1 and 61.
- Turn the adjusting trimmer ZERO (Fig. 7) to adjust the output current signal rate measured on the terminals 81-82 to 4mA.
- Set the actuator to the position "open".
- Turn the adjusting trimmer GAIN (Fig. 7) to adjust the output current signal rate measured on the terminals 81-82 to 20mA.
- Check the output signal of the converter in the both limit positions, and repeat the procedure if needed.
- Having the transmitter adjusted put the jumper again on the terminals 81 and 82 in case that the output signal wont be used (the circuit through the terminals 81 and 82 should be closed).
- Connect the control signal to the terminals 86/87 and 88.

3.4.2 EPV – 3-wire version (Fig. 8)

The resistive transmitter with the converter is in the plant adjusted to have the output current signal metered on the terminals 81-82 (the wiring diagram Z257 - without any power supply, or Z260 - with a power supply) as follows:

- in the position "open"..... 20 mA or 5 mA
- in the position "closed" 0 mA or 4 mA

according to the specified version of the converter.

If the transmitter requires a new adjustment follow these steps:

- Put the actuator to the position „closed“ and switch the power supply off.
- Adjust the resistive transmitter according to the previous chapter. The resistance is to be metered on the terminals X-Y (Fig. 8). The used transmitter resistance is 2000 W or 100 W.
- Switch the converter's power supply on.
- Turn the adjusting trimmer ZERO (Fig. 8) to adjust the output current signal rate measured on the terminals 81-82 to 0 mA or 4mA.
- Set the actuator to the position "open".
- Turn the adjusting trimmer GAIN (Fig. 8) to adjust the output current signal rate measured on the terminals 81-82 to 20mA or 5 mA.
- Check the output signal of the converter in the both limit positions, and repeat the procedure if needed.

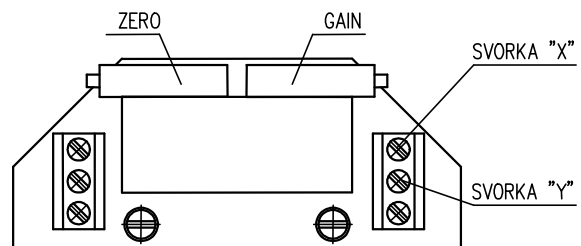

Fig. 8

Note:

The output signal of (0-20mA, 4-20mA or 0-5mA - according to the specification) can be adjusted at the range from 85 up to 100% of the rated stroke stated on the actuator's nameplate. At values less than 85% the value of the output signal is reduced proportionally.

3.5 Adjustment of Capacitive Transmitter CPT1/A (Fig.9)

The chapter describes adjustment of the capacitive transmitter to the specified parameters (standard values of output signals) in case they are reset. The capacitive transmitter serves as a position transmitter of electric actuators with unified output signal of 4÷20 mA in electric actuators **ST 0.1**, or as a feedback of a position controller, or if required it functions also as a remote position transmitter of electric actuators with unified output signal of 4÷20 mA in electric actuators **STR 0.1 with controllers**.

Note:

In case that reversed output signals are needed (in the position "OPEN" minimum output signal) contact personnel of service centres.

The capacitive transmitter CPT1/A is adjusted by the producer to the fixed operation stroke according to the order and wired according to the wiring diagrams placed into the cover. Check the power supply of the user after connecting to terminal of the terminal board before the transmitter is electrically checked. Adjustment of the capacitive transmitter can be performed when the position switches are adjusted. The adjustment is performed with the power supply of 230/220 V/50 Hz and ambient temperature of $20 \pm 5^\circ\text{C}$.

The following versions of electric actuators with built capacitive transmitters can be specified :

- A) The version without any power supply** (2-wire version) for EA **ST 0.1**
- B) The version with a power supply** (2-wire version) for EA **ST 0.1**
- C) The version CPT as a feedback to the position controller** for EA **STR 0.1 with controllers**

A.) Adjustment of the Capacitive Transmitter without any Power Supply

Before connecting check the power supply. The measured voltage should be in range from 18 up to 28 V DC.



The voltage of the power supply must not be in any case higher than 30 V DC. The transmitter can be irreversibly damaged!

While checking or adjusting the output signal of 4÷20 mA follow these steps:

- Connect a mA meter of precision class 0,5 and loading resistance lower than 500Ω serially with the transmitter (pole „-“; terminal 82)
- Put the actuator to the position "CLOSED", the signal value should decrease.
- Check the signal value for the position "CLOSED" (4 mA).
- Tune the signal with loosening the fixing screws (15) and turning the trimmer (10) until the required value of 4 mA is reached. Tighten the fixing screws.
- Put the actuator to the position "OPEN", the signal value should raise.
- Check the signal value for the position "OPEN" (20 mA).
- Tune the signal with turning the trimmer (20) until the required value of 20 mA is reached.
- Check the signal value for the position "CLOSED" and then for the position "OPEN".
- Repeat the procedure until the change from 4 to 20 mA is reached with deviation less then 0,5 %.
- Disconnect the meter and lock the screws with a varnish.

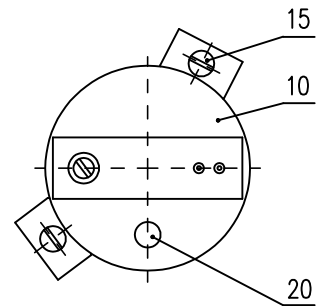

Fig.9

B.) Adjustment of the Capacitive Transmitter with the Power Supply

- 1.) Check the power supply: 230/220 V AC $\pm 10\%$ on the terminals 78,79
- 2.) While checking or adjusting the output signal of 4÷20 mA follow these steps:
 - Connect a mA meter of precision class 0,5 and loading resistance lower than 500Ω on the terminals 81, 82.
 - Follow the procedure described in the previous chapter A.

C.) Adjustment of the Capacitive Transmitter served as a Feedback of the Position Controller

While checking or adjusting the output signal of 4÷20 mA follow these steps:

- Disconnect the circuit on the terminals 81 and 82 removing the jumper.
- Connect power supply to the terminals 1 and 61.
- Disconnect the control signal from the terminals 86 and 88.
- Put the actuator to the direction "OPENING" or "CLOSING" with the handwheel or connecting power supply to the terminals 1 and 200 for the direction "OPENING", or 1 and 24 for the direction "CLOSING".
- Connect a mA meter of precision class 0,5 (e.g. digital) and loading resistance lower than 500Ω on the terminals 81,82.
- Follow the procedure for the version without any power supply described in the previous chapter A.
- Having the transmitter adjusted put the jumper again on the terminals 81 and 82 in case that the output signal wont be used (the circuit through the terminals 81 and 82 should be closed).
- Connect the control signal to the terminals 86 and 88.



The user has to arrange grounding of the 2-wire circuit of the capacitive transmitter to the electrical ground of a joined controller, computer, etc. The grounding should be performed only in one place in any part of the circuit outside the electric actuator!

Note:

The trimmer (20) can be used to adjust the output signal of the capacitive transmitter to any value of operation stroke in range from ca 40% up to 100% of the value of the operation stroke adjusted by the producer and stated on the actuator's nameplate.

3.6 Adjustment of position controller (Fig. 10)

The built-in position controller REGADA of new generation is a user-friendly control system to control actuators with an analogue signal. The controller takes advantages of high-power RISC processor MICROCHIP to perform all functions. It provides also continuous automotive diagnostics of the system, error messages as well as number of relay switching and number of controller's operation hours. Placing an analogue signal onto the input terminals of the terminal board 86/87 (GND, -) and 88 (+) causes that the EA output is reset.

Required parameters and functions can be programmed using function buttons SW1 - SW2 and LED diodes D3 - D4 placed directly on the controller, see Table 2.

3.6.1 Setting of controller

The controller's microprocessor unit is in the production plant programmed to parameters given in **Table 2** (Note 2).

Setting of the controller is performed using buttons and LED diodes.

Adjust the position and thrust switches and the position transmitter before adjustment of the controller.

Laying of adjusters and signalling elements on the board of the REGADA controller is shown on Fig. 10:

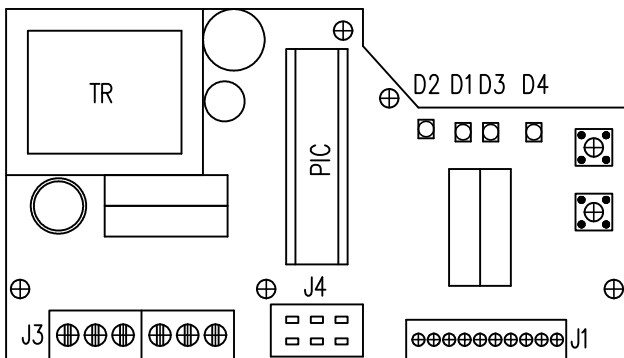

Fig. 10

SW1 button	starts an initialisation routine and allows listing in the adjust menus
SW2 button	setting of parameters in the chosen menu
D1 diode	power on indication
D2 diode	motion to the direction "opening" indication (green) - "closing" (red) indication
D3 diode	(yellow light) number of blinking codes indicates chosen adjust menu
D4 diode	(red light) number of blinking codes indicates adjusted parameter of the controller from the chosen menu

Table 2:

D3 (yellow) diode number of blinking	Adjust menu	D4 (red) diode number of blinking	Adjusted parameter
1 blink	control signal	1 blink	0-20mA
		2 blinks	4-20 mA (*) (**)
		3 blinks	0-10V DC
2 blinks	response for signal SYS-TEST	1 blink	EA opens receiving signal SYS
		2 blinks	EA closes receiving signal SYS
		3 blinks	EA stops receiving signal SYS (*)
3 blinks	mirroring (ascending/descending characteristics)	1 blink	EA CLOSING at increasing of control signal
		2 blinks	EA OPENING at increasing of control signal (*)
4 blinks	insensitiveness of controller	1 to 10 blinks	insensitiveness of controller of 1-10% (3% set by the producer) (*)
5 blinks	way of regulation	1 blink	narrow thrust
		2 blinks	narrow position (*)
		3 blinks	wide thrust
		4 blinks	wide position

Notes:

1. The controller at autocalibration automatically sets the feedback type - resistant/current
2. (*) Parameters set in the production plant, if customer has not stated else.
3. (**) Input signal 4 mA - position "closed"
 20 mA - position "open"

Standard setting of controller (programmed RESET of controller) - in case of any problems with setting of the parameters it is possible with pressing both **SW1 and SW2** at the same time and then switching power on to set the standard parameters.

Controller setting procedure:

The initialisation routine starts at the switched-on controller, zero system deviation and short pressing of the SW1 button for ca 2 sec (i.e. until the diode D3 got on). Loosing the button some of the default menus starts (usually control signal) what is shown with 1 blink on the D3 diode as well as one of the default parameters (usually control signal of 4-20mA) what is shown with 1 blink on the D4 diode. Then the required parameters of the controller can be changed according to Table 2:

- press shortly the SW1 button to list the menu shown with the blinking number on the D4 diode.
- press shortly the SW2 button to set parameters shown with the blinking number on the D4 diode.

After changing the parameters according to the user's requirements, switch the controller to autocalibration using the SW1 button pressed for approx. 2 sec (i.e. until the diode D3 lights up), which is signaled by flashing the yellow LED D3 6 times. During this process, the controller checks the feedback transmitter and the direction of rotation, moves the ES to the open and closed positions, measures the inertial masses in the "OPEN" and "closes" directions and saves the set parameters in the EEPROM memory. In case that during the initialisation process an error occurs (e.g. in connection or adjustment) the initialisation process will be interrupted and the controller with the D4 diode reports about the type of the error. Else after finishing the initialisation process the controller is put into the regulation mode.

Error messages of the controller with D4 diode at initialisation

- 4 blinks improper connection of the thrust switches
- 5 blinks improper connection of the feedback transmitter
- 8 blinks bad sense of actuator's turning direction or adverse connection of the feedback transmitter

3.6.2 Watching operation and error states

Watching operation and error states is possible with the EA open.

a) Operation status with the D3 LED diode indicating:

- it is continuously lighting - the controller regulates
- it is continuously not lighting - system deviation in the insensitiveness range - the EA has stopped

b) Error state with the D4 and D3 LED diodes indicating - D4 continuously lighting, D3 indicates error state with blinking

1 blink (repeated)	indication of the "TEST" mode - the EA is put to the position according to the signal in the "TEST" menu (at connecting the 66 and 86/87 terminals)
2 blinks (repeating after short pause)	missing of control signal - the EA is put to the position according to the signal in the "TEST" menu
4 blinks (repeating after short pause)	thrust switches activity indication (the EA switched-off with the thrust switches in a mid-position)
5 blinks (repeating after short pause)	failure of the feedback transmitter - the EA is put to the position according to the signal in the "TEST" menu
7 blinks (repeating after short pause)	control signal (current at range 4-20mA less than 4mA (3.5mA)).

4. Service, maintenance and troubleshooting

4.1 Service



1. In general it is provided that service of the EA is performed by a qualified worker in accordance with requirement given in Chapter 1!
2. After putting the EA into operation it is needed to verify whether during manipulation any scratch on surface occurred, it is to be removed to prevent actuator against corrosion!

The EA ST/STR requires just negligible service. Proper putting into operation is a recondition of reliable operation.

The service of the EA leads from the operation conditions and usually resides in information processing for further arranging of required functions.

The stuff has to perform prescribed maintenance to prevent the EA during operation against impacts of environment, which exceed the frame of allowed influences.

Manual control:

If needed (during adjusting, function checking, failure etc.) the stuff can change setting of the controlled body using the handle.

Instructions for manual control:

- Switch the power supply off.
- Turn the button for gear disengagement to the right by 90° (Fig. 11, the button arrow shows the symbol of hand) what disengages the gear in the actuator.
- Set the actuator to the chosen position:

a) *For actuators with manual control:* push and turn the handle located on the actuator upper cover. While turning counter-clockwisely the valve is turning in the direction "open". Having the valve in the required position turn the button for gear disengagement to the position "motored operation" what engages the gears. Put the handle back to its original position.

b) *For actuators without manual control* - using the fork wrench. Remove top cover, put fork wrench on 6-edged shaft of manual control. While turning counter-clockwisely the valve is turning in the direction "open". After resetting of the valve put the gear disengagement button to the original position and cover the actuator.

Note:

After putting the button for disengaging of gearing again to the position of motor operation if the gearing is not connected it is needed to turn the handle to put the gears into mesh.

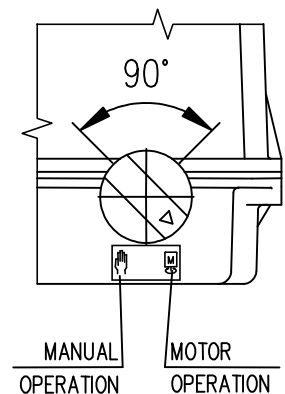

Fig.11

In case of manual control the set of end positions are not detuned.

4.2 Maintenance - extent and periodicity

All screws and nuts affecting tightness and protection (IP) must be tighten during the inspection and maintenance. Similarly, once a year should be checked and if necessary tighten mounting screws of the terminal wires and assuring of the slip-on joints with wires.

The interval between two preventive inspections is four years.

In case of damage or after 6 years of the actuator's operation the replacement of cover seals and oil filling seals must be done.

The grease in the supplied actuators is designed for the lifetime of the product. It is not necessary to change the grease during the operation of the actuator.

Lubrication:

- - gear part – grease HF 401/0 (GLEIT- μ) resp. GLEITMO 585 K
- - linear adapter – grease GLEIT- μ - HP 520M.



Lubrication of the valve stem is independent on maintenance of the EA!

After every potential flooding of the product check, whether there is no water inside. After eventual water penetration, dry the product before repeated putting into operation and replace damaged sealings, resp. other parts of EA. identically check also tightness of cable bushings and replace them, if they are damaged.

- Every six months it is recommended to perform one check move in frame of adjusted operation stroke to verify reliability of functioning with setting back to the original position.
- If the audit rules do not determine else the inspection of EA is performed ones a year and tightening of all connecting and grounded screws have to be checked to avoid overheating.
- After 6 months from putting of EA into operation and once a year it is recommended to check tightening of fixing screws between the EA and the valve. (Tighten the screws with the cross system.)
 - While connecting and disconnecting of the EA check the tightness of cable glands – those with damaged sealings should be replaced by new ones of the approved type!
 - Keep the EA clean and take care about removing impurities and dust. The cleaning has to be performed regularly according to the operation possibilities and requirements.



4.3 Troubleshooting

At failure of power supply the EA stops in the position where it was before the failure. If needed the EA can be set only with the manual control (the handle). After restoration of power the EA is prepared for operation.

In case of failure of any element of the EA it can be changed by a new one. Entrust the change to a service centre.

In case of an EA failure, which cannot be eliminated directly in operation, follow instructions for under-guaranty and after-guaranty service.

For controller repair a F1,6 A subminiature fuse for PCB should be used, alternatively also F 2A, 250 V e.g. Siba type 164 050.1,6 or MSF 250, and for DB voltage source repair a M160 mA, 250V fuse, e.g. Siba, or MSF 250.

Note:

If the EA requires dismantling follow the chapter "Dismantling".



Taking the EA to pieces for repair purposes is allowed only by professionally qualified persons trained in the production plant or by a contracted service centre!

5. Spare parts

Spare part list:

Spare part	Order Nr.	Position	Figure
Electric motor; 15 W; 230/220 V AC; 50 Hz	63 592 306 63 592 311	1	1
Electric motor; 20 W; 24 V AC/DC	63 592 388	1	1
Electric motor; 15 W; 3x400/3x380; 50 Hz	63 592 332	1	1
Micro switch CHERRY D6 G A1LB	64 051 466	1, 2, 3	6
Micro switch CHERRY D6 G A1BA	64 051 447	2	1
Capacitive transmitter CPT 1	64 051 499	10	9
Resistant wire transmitter (potentiometer) RP19; 1x100	64 051 812	8	6
Resistant wire transmitter (potentiometer) RP19; 1x2000	64 051 827	8	6
Resistant wire transmitter (potentiometer) RP19; 2x100	64 051 814	8	6
Resistant wire transmitter (potentiometer) RP19; 2x2000	64 051 825	8	6
Sealing – IP 65	04 709 000	-	-
Sealing – IP 67	62 732 376	-	-

6. Enclosures

6.1 Wiring diagrams

Wiring diagrams for EA ST

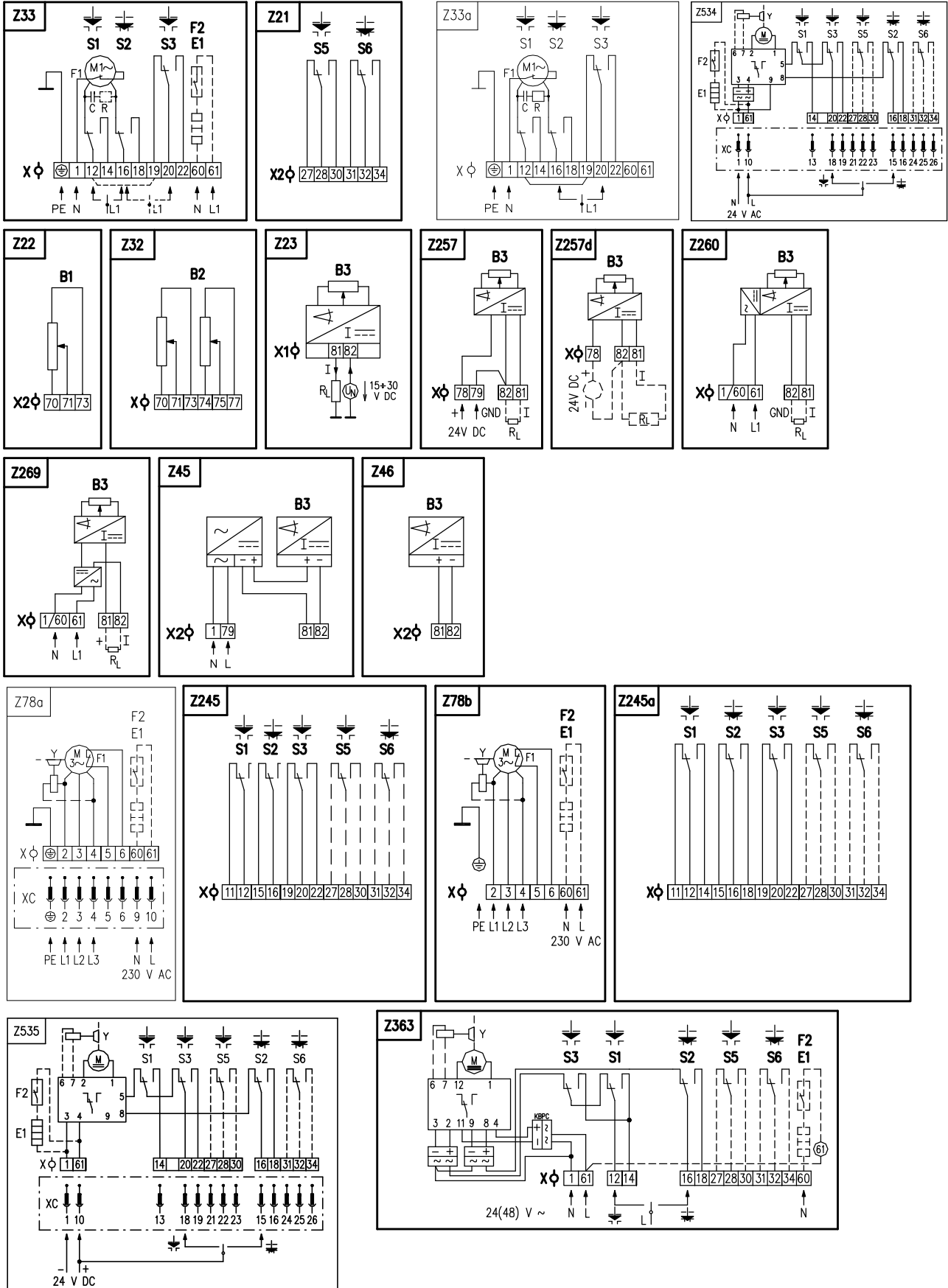

Wiring diagrams for EA STR with controller

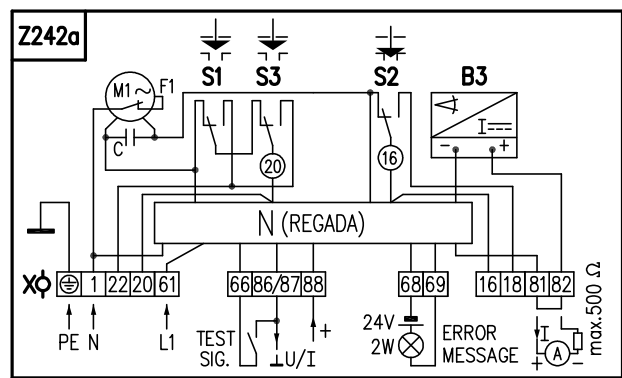
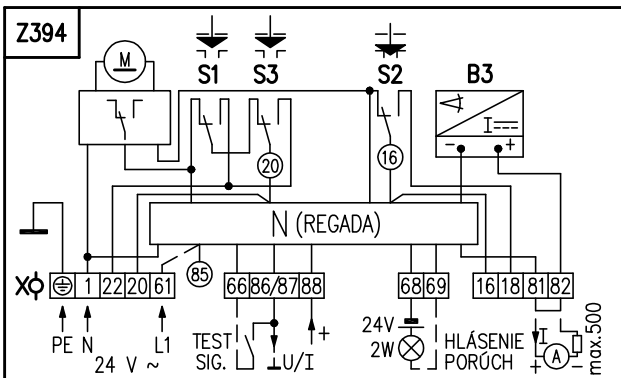
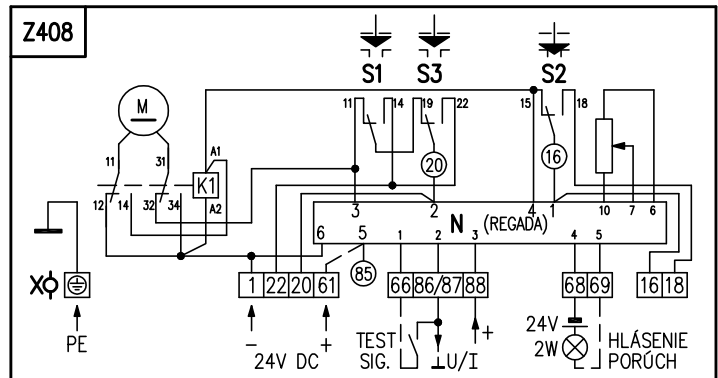
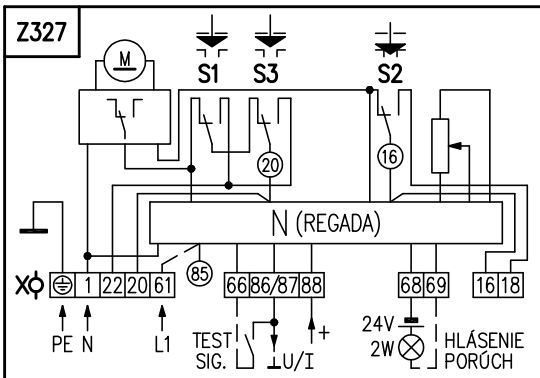
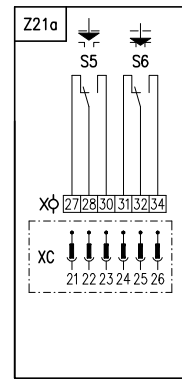
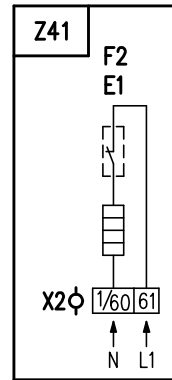
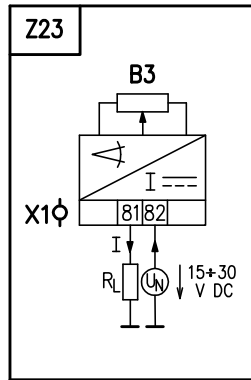
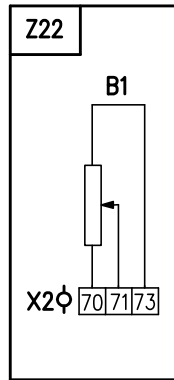
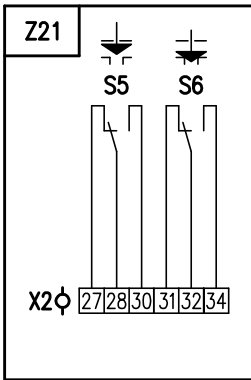
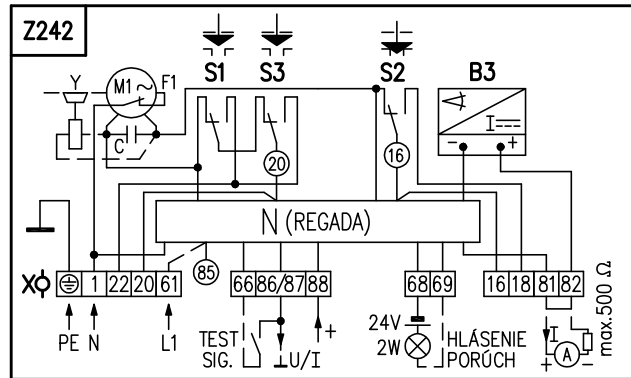
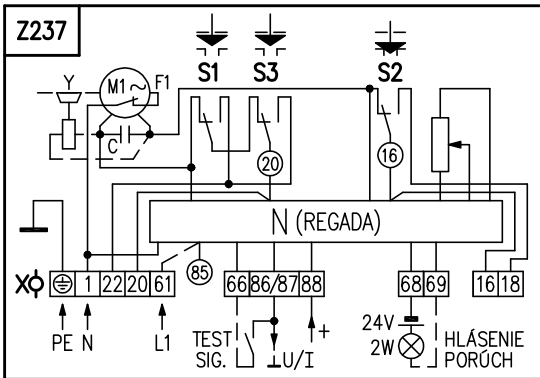





















Legend:

Z21, Z21aadditional position switches connection
Z22single resistant transmitter connection
Z232-wire version of EPV – without power supply connection
Z32double resistant transmitter connection
Z33,Z33aelectrical motor connection with thrust switches and with position switch
Z41space heater with thermal switch connection
Z45capacitive transmitter (2-wire) - with power supply connection
Z46capacitive transmitter (2-wire) - without power supply connection
Z78a/Z78bconnection of 3-phase electric motor
Z237connection of EA STR 0.1 with a controller with resistive feedback - for supply voltage 230/220 V AC
Z242,Z242a	..connection of EA STR 0.1 with a controller with current feedback
Z245/Z245a	...connection thrust and position switches for 3- phase electric motor
Z257/Z257d	...3-wire version of EPV - without power supply connection
Z2603-wire version of EPV - with power supply connection
Z2692-wire version of EPV – with power supply connection
Z327connection of EA STR 0.1 with a controller with resistive feedback - for supply voltage – 24 V AC
Z363connection of EA ST 0.1 for electric motor – 24 V AC
Z394connection of EA STR 0.1 with a controller with current feedback – 24 V AC
Z408connection of EA STR 0.1 with a controller with resistive feedback - for supply voltage 24 V DC
Z535connection with voltage 24 V DC
Z534connection with voltage 24 V AC
B1 remote transmitter-resistive, single
B2 remote transmitter-resistive, double
B3 electronic position transmitter (EPV) or capacitive transmitter
C capacitor
E1 space heater
F1 electric motor thermal protection
F2 space heater's thermal switch
I(U) input (output) current (voltage) signals
M1 electric motor
N controller
R resistor
R _L load resistance
S1 thrust switch "open"
S2 thrust switch "closed"
S3 positional switch "open"
S5 additional positional switch "open"
S6 additional positional switch "closed"
X, X1, X2 terminal board

Notes:

1. In case, that output signal from capacitive transmitter (wiring diagram Z242) is unused (incomplete circuit between terminal 81 and 82), it is required to connect clamps 81 and 82 by jumper (jumper is connected at manufacturing plant for connecting to terminal board only). By using output current signal from capacitive transmitter it is needed to remove jumper.
2. At version EA with feeding voltage 24 V AC is not needed to connect ground wire PE.

SWITCH OPERATION CHART

switch	terminals	open	close
S1	NC - COM		
	COM - NO		
S2	NC - COM		
	COM - NO		
S3	NC - COM		
	COM - NO		
S5	NC - COM		
	COM - NO		
S6	NC - COM		
	COM - NO		







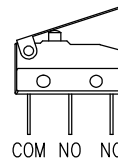
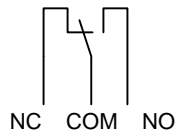













operating stroke

Contact closed

Switches: S1, S2, S3, S5, S6:



SWITCH OPERATION CHART Z245a:

switch	terminals	open	close
S1	11 - 12		
	12 - 14		
S2	15 - 16		
	16 - 18		
S3	19 - 20		
	20 - 22		
S5	27 - 28		
	28 - 30		
S6	31 - 32		
	32 - 34		

operating stroke

Connected contact

6.2 Dimensional drawings

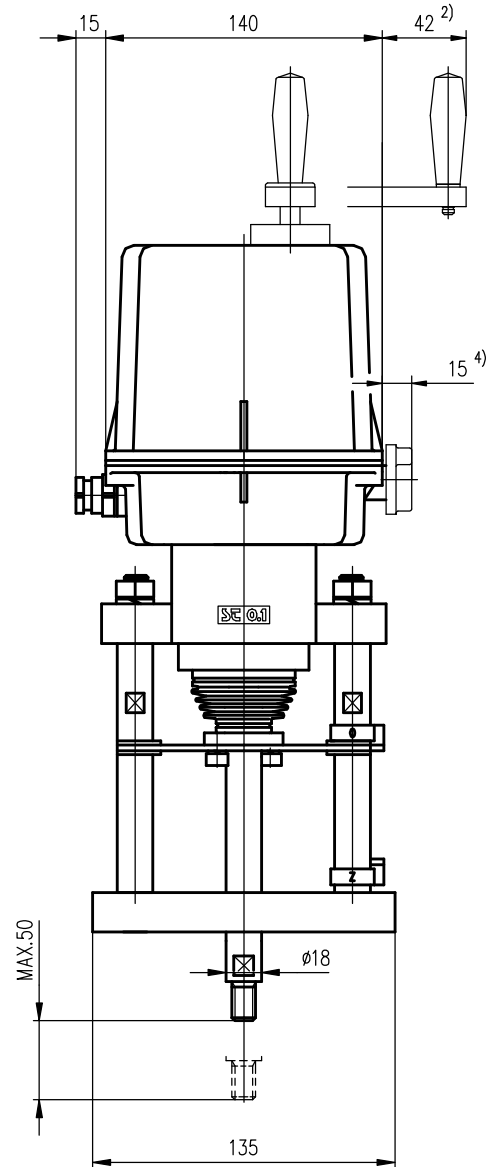
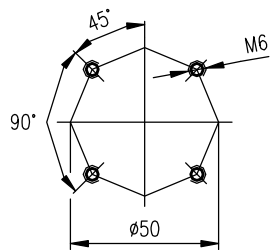
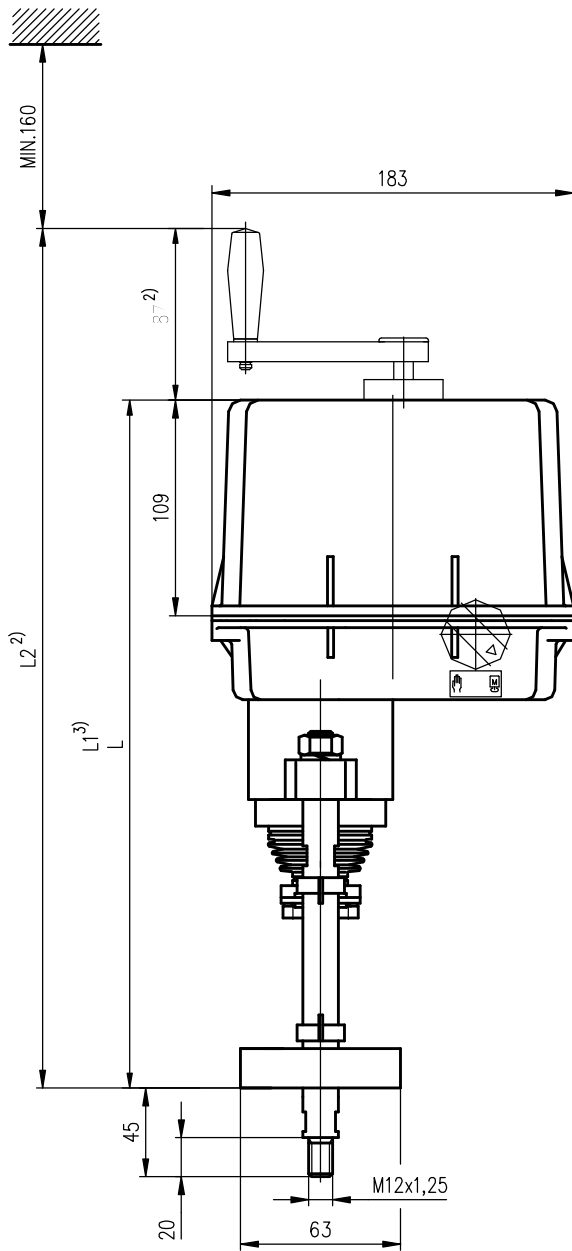

335	338	422
L	L1	L2

P-1201

- 2) VALID FOR MANUAL CONTROL WITH PERMANENT STANDBY
- 3) VALID FOR MANUAL CONTROL WITHOUT PERMANENT STANDBY
- 4) VALID FOR MANUAL CONTROL

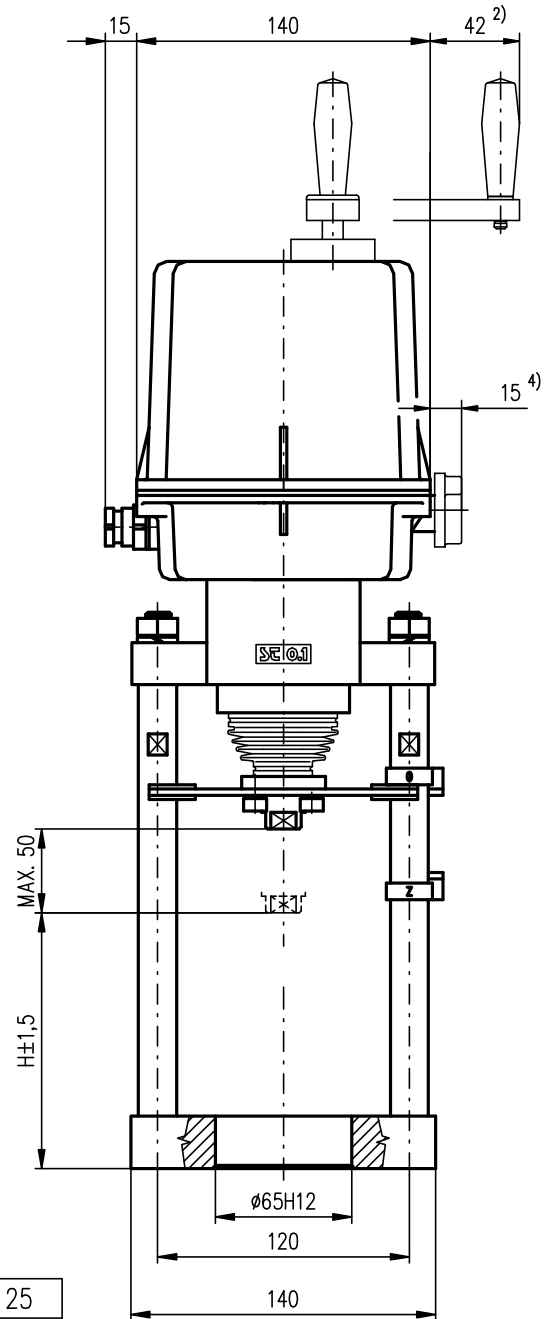
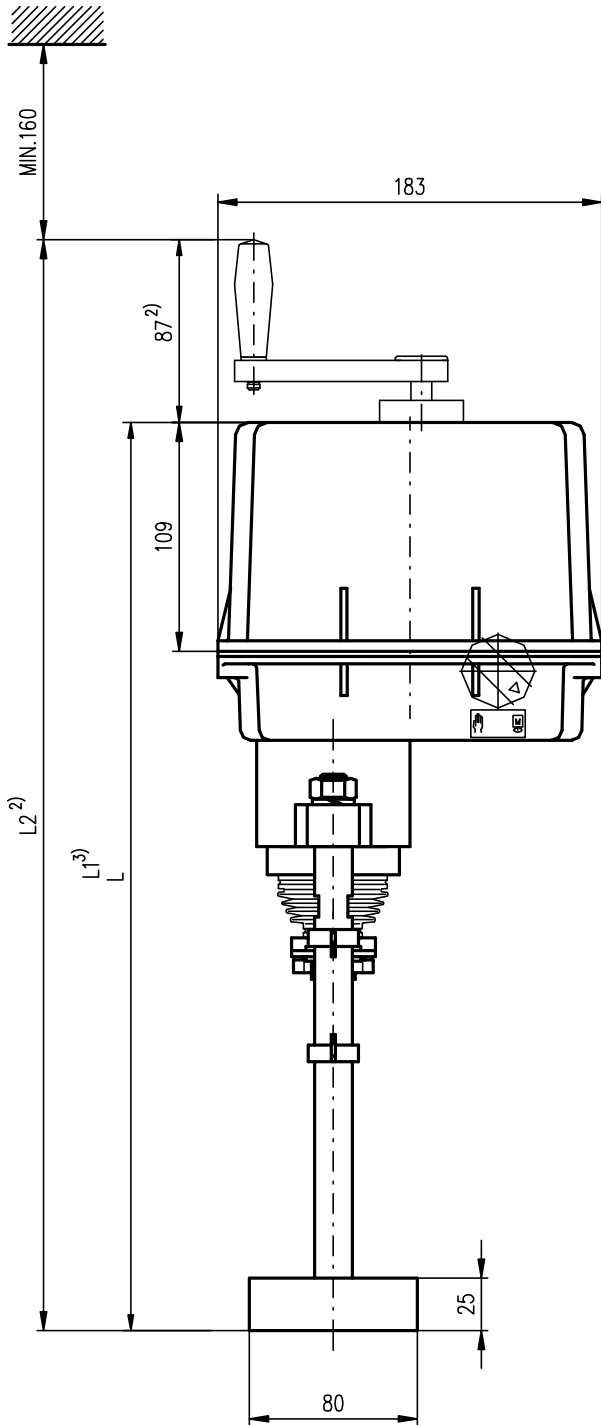

P1202/G	446	449	533	124	58	25
P1202/F	416	419	503	94	58	20
P1202/E	426	429	513	102	57,15	17
P1202/D	416	419	503	92	57,15	17
P1202/C	434	437	521	112	80 H8	–
P-1202/B	434	437	521	110	65,12 H12	25
P-1202/A	425	428	512	103	65,12 H12	25
VERSION	L	L1	L2	H	H	H

- 2) VALID FOR MANUAL CONTROL WITH PERMANENT STANDBY
- 3) VALID FOR MANUAL CONTROL WITHOUT PERMANENT STANDBY
- 4) VALID FOR MANUAL CONTROL

P-1202/A, B

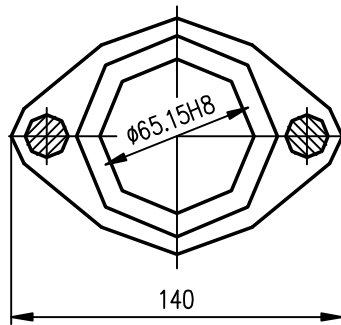
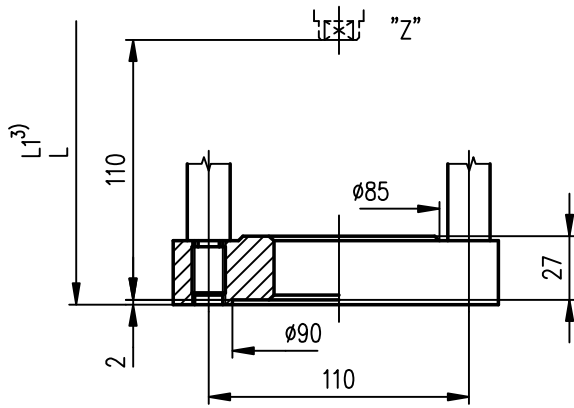

P-1202/B

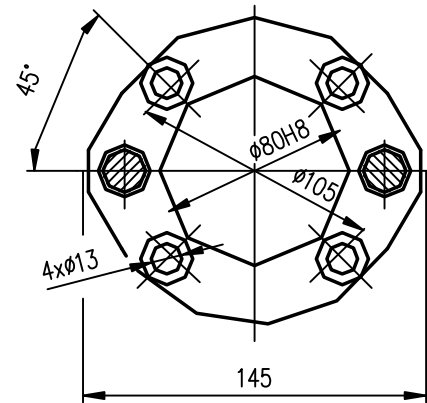
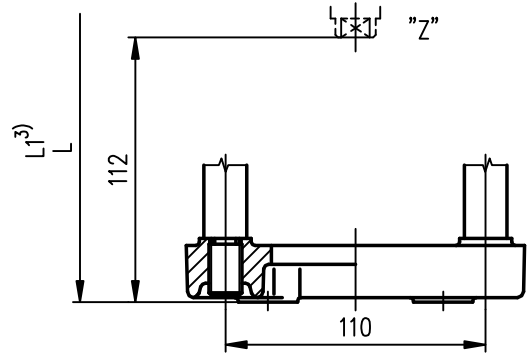

P-1202/C

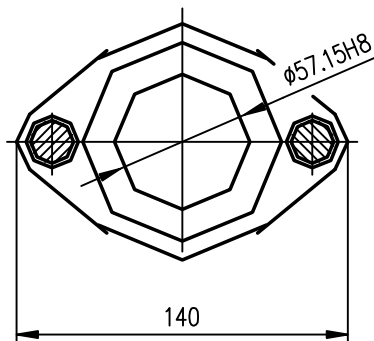
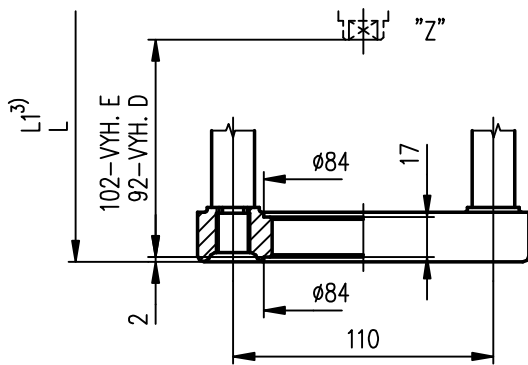

P-1202/D,E

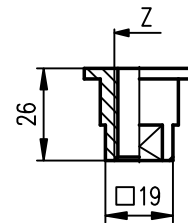

10	M14
09	M12x1,25
08	W 1/2"
07	W 3/8"
06	W 5/16"
05	M16x1,5-6H
04	M12x1,5-6H
03	M12-6H
02	M10x1,5-6H
01	M10x1-6H
VERSION	Z

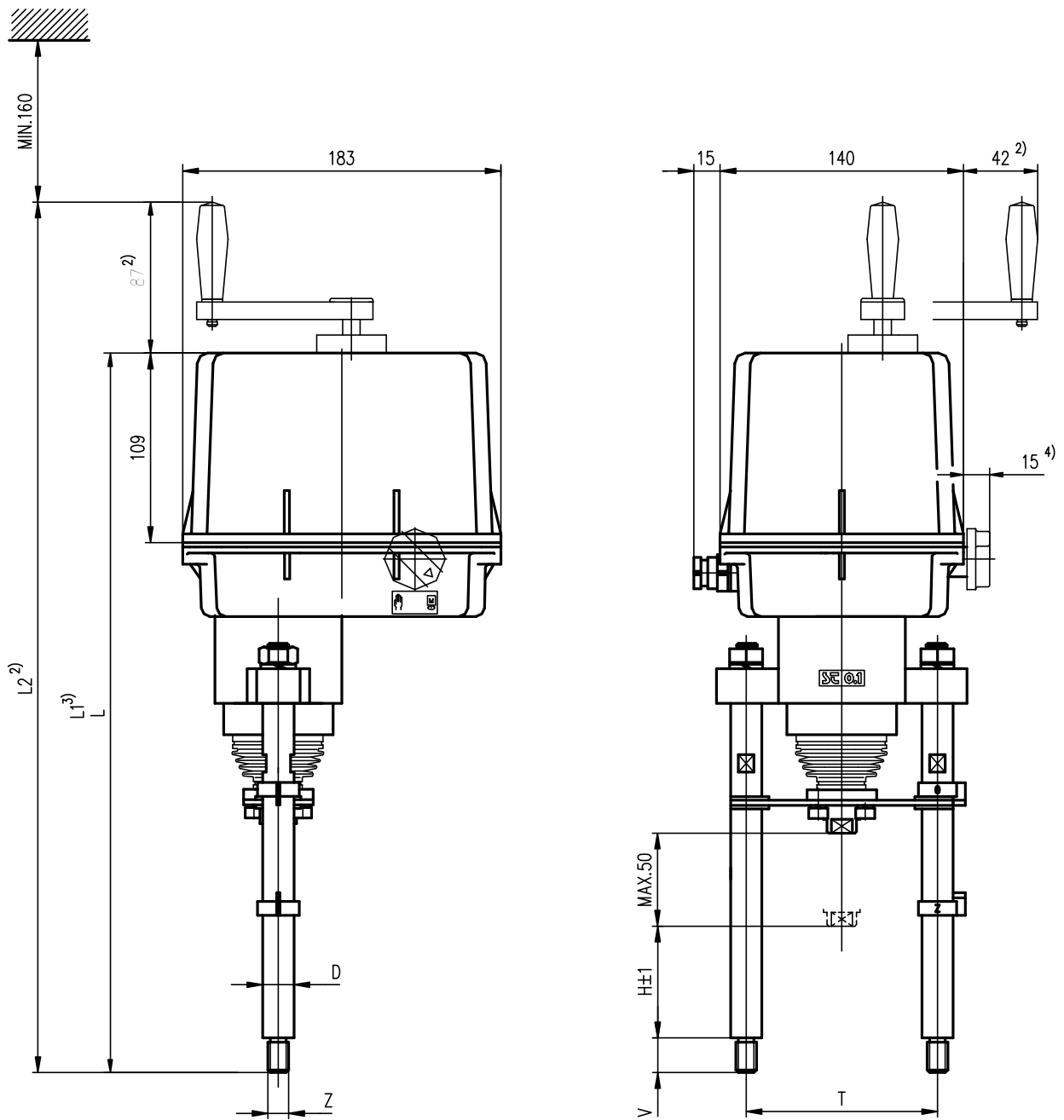

F	100	110	18	M16	16	448	451	535	
E	100	57	18	M16	16	395	398	482	
D	100	27	18	M16	16	365	368	452	
C	110	80	18	M12	32	434	437	521	WITH NUTS
B	110	42	18	M12	20	384	387	471	
A	110	127	18	M12	20	469	472	556	
VERSION	T	H	D	Z	V	L	L1	L2	NOTE

- 2) VALID FOR MANUAL CONTROL WITH PERMANENT STANDBY
- 3) VALID FOR MANUAL CONTROL WITHOUT PERMANENT STANDBY
- 4) VALID FOR MANUAL CONTROL

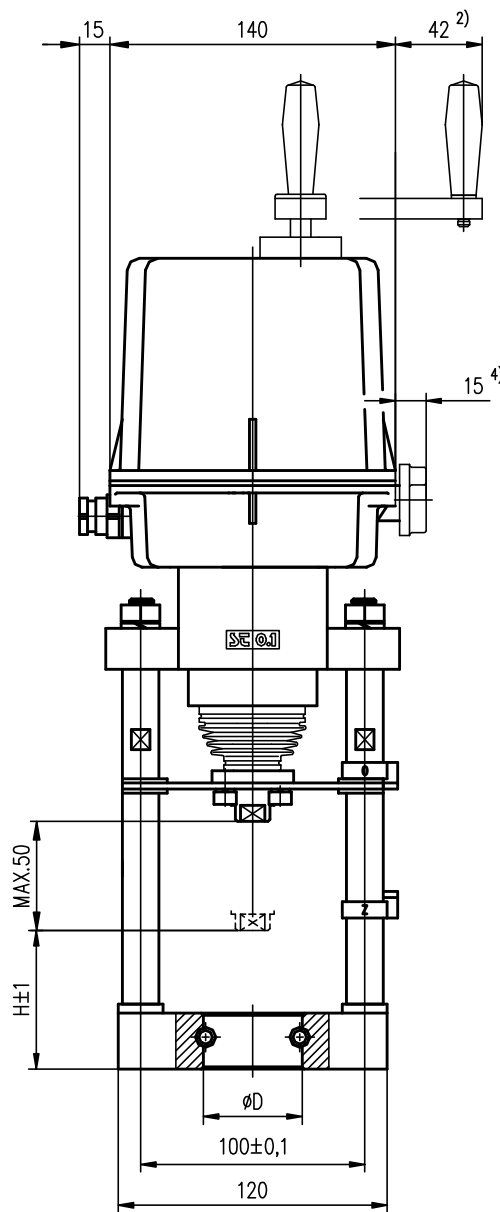
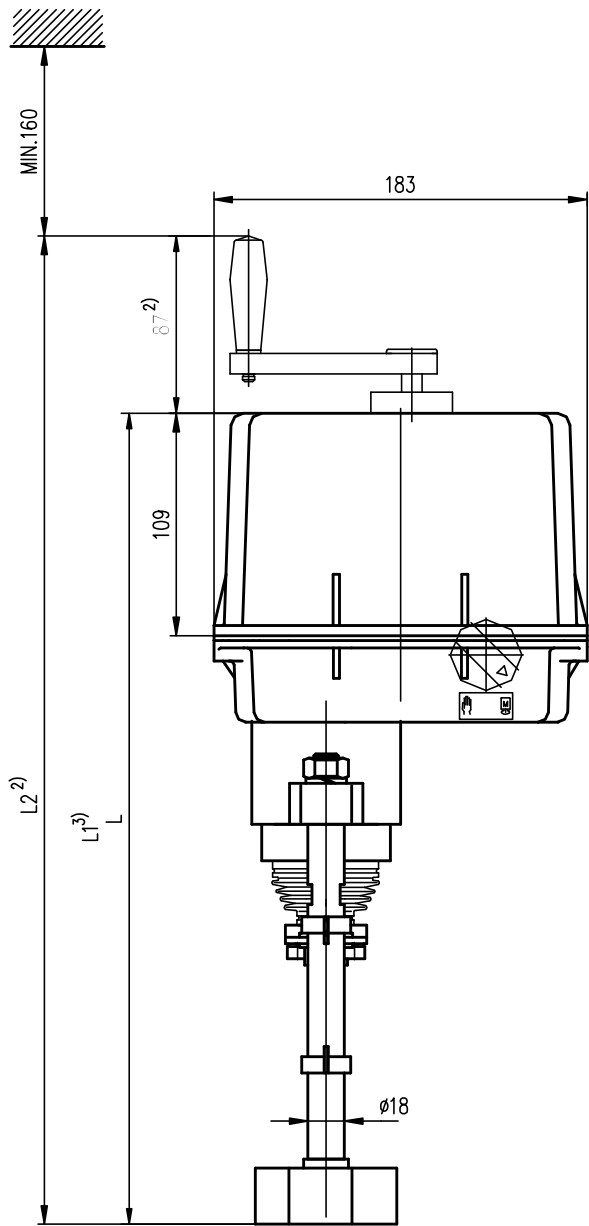

- 2) VALID FOR MANUAL CONTROL WITH PERMANENT STANDBY
- 3) VALID FOR MANUAL CONTROL WITHOUT PERMANENT STANDBY
- 4) VALID FOR MANUAL CONTROL

P-1418/B	86	60	400	409	487
P-1418/A	59	38	373	376	460
VERSION	H	D	L	L1	L2

P-1418

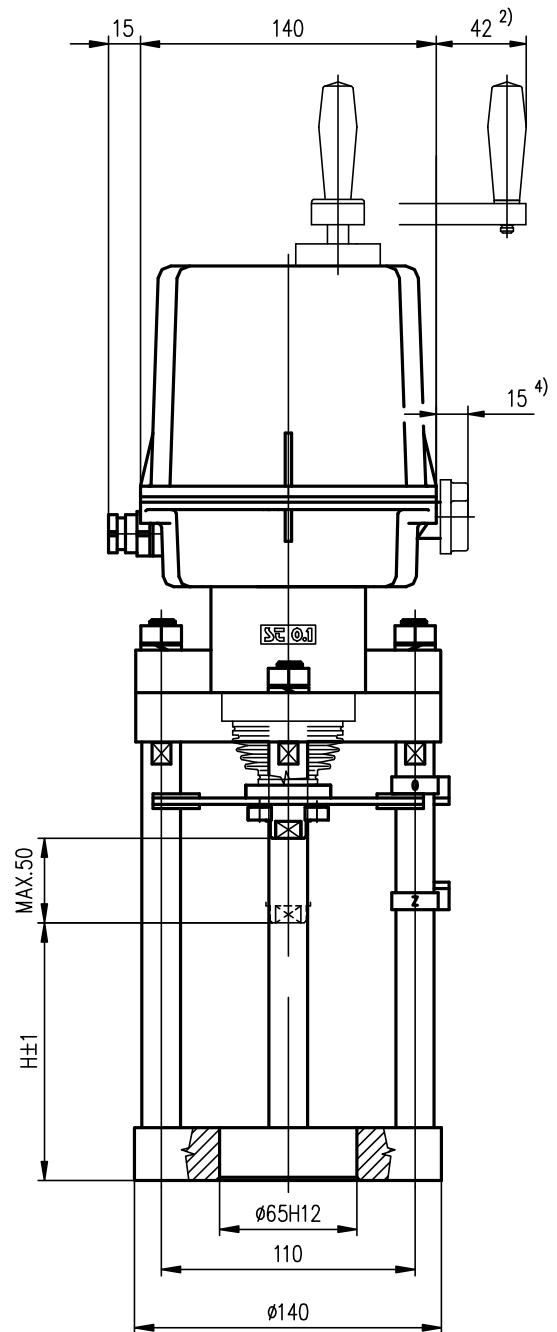
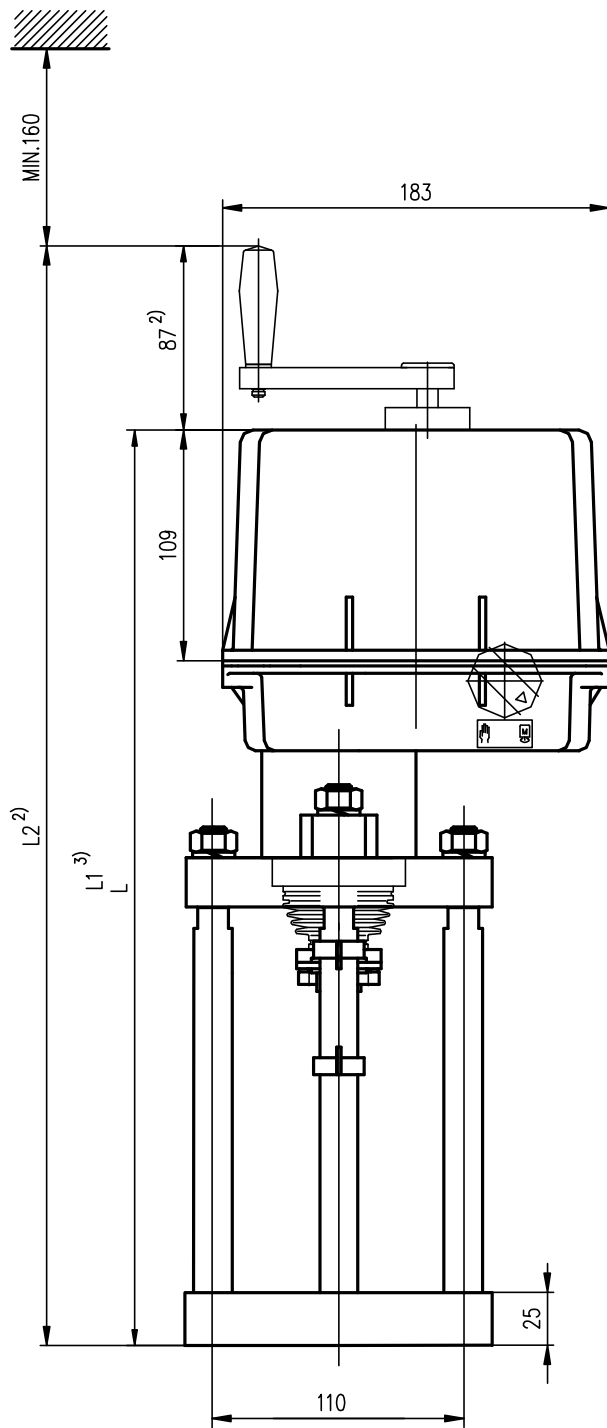

P-1468/B	434	437	521	110
P-1468/A	425	428	512	103
VERSION	L	L1	L2	H

P-1468

- 2) VALID FOR MANUAL CONTROL WITH PERMANENT STANDBY
- 3) VALID FOR MANUAL CONTROL WITHOUT PERMANENT STANDBY
- 4) VALID FOR MANUAL CONTROL

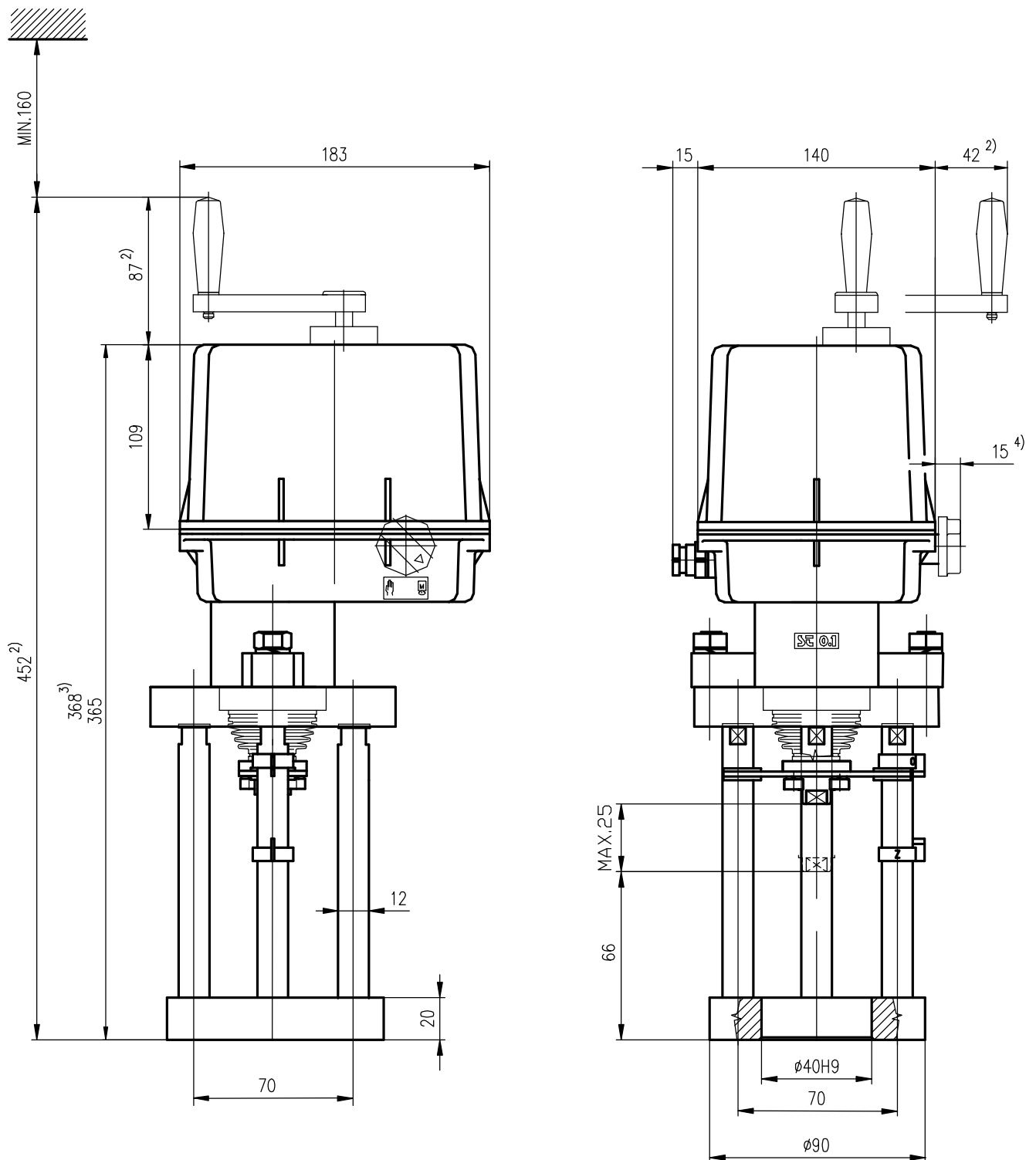

- 2) VALID FOR MANUAL CONTROL WITH PERMANENT STANDBY
 3) VALID FOR MANUAL CONTROL WITHOUT PERMANENT STANDBY
 4) VALID FOR MANUAL CONTROL

P-1470

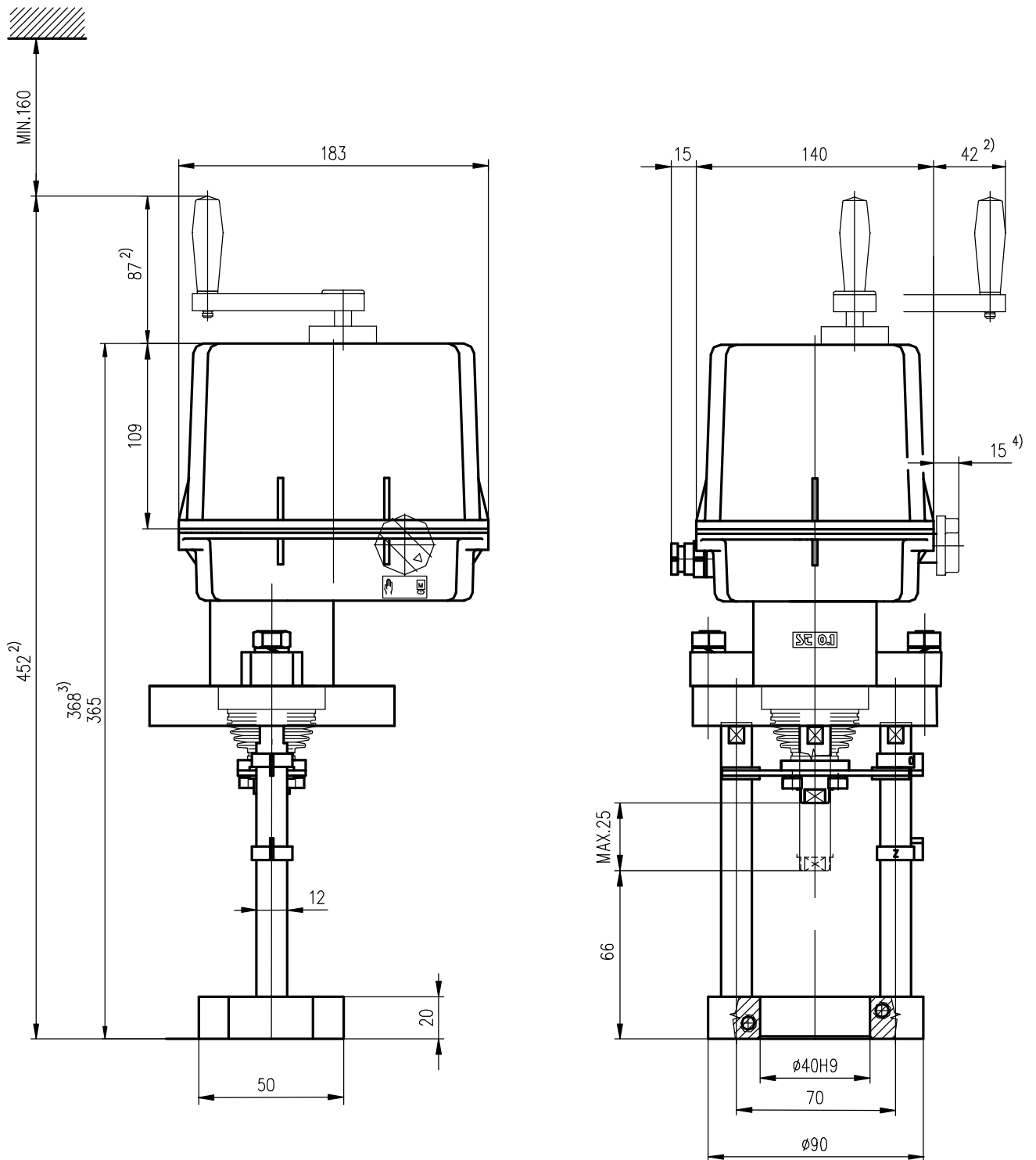

- 2) VALID FOR MANUAL CONTROL WITH PERMANENT STANDBY
- 3) VALID FOR MANUAL CONTROL WITHOUT PERMANENT STANDBY
- 4) VALID FOR MANUAL CONTROL

P-1472

6.3 Guarantee service check report

Service center:	
Date of repair:	Guarantee repair no.:
User of actuator:	Claim applied by:
Actuator type number:	Actuator production number:
Product claim fault:	Detected product fault:
Used spare parts:	
Remarks:	
Issued on a day:	Signature:

6.4 Post guarantee service check report

Service center:	
Date of repair:	
User of actuator:	Actuator operating place :
Actuator type number:	Actuator production number:
Detected product fault:	
Used spare parts:	
Remarks:	
Issued on a day:	Signature:

6.5 Commercial representation

Slovak Republic:

Regada, s.r.o.,
Strojnícka 7,
080 01 Prešov
Tel.: +421 (0)51 7480 460,
Fax: +421 (0)51 7732 096,
E-mail: regada@regada.sk

Czech Republic:

Exclusive representation Regada, s.r.o. (Ltd.) for sale of electric actuators

Regada Česká, s.r.o.
Nám. 5. května 17,
252 25 Jinočany,
PRAHA – západ,
Tel.: +420 257 961 302
Fax: +420 257 961 301