



INSTALLATION, SERVICE AND MAINTENANCE INSTRUCTIONS



***Electric linear actuators Rematic with the DMS3,
DMS3 M1, DMS3 M2, DMS3 P1, DMS3 P2
electronic control STR 1PA, STR 2PA***

TEST CERTIFICATE

ELECTRIC LINEAR THRUST ACTUATOR STR 1PA, STR 2PA	
Type number	Power supply V Hz
Serial number	Max. load thrust N
Production year	Switch-off thrust N
Wiring diagram	Operating speed mm/min
.....	Operating stroke mm
.....	Control
.....	Input operation signal
Warranty period months	Output signal
Serial number of electric motor	
Serial number of control unit	
Tests made by	Packed by
Date	Signature and stamp

COMPLETENESS CERTIFICATE

Used valve	
Assembled by: Firm	
Name	
Warranty period months	
Date	Signature and stamp.....

INSTALLATION CERTIFICATE

Location	
Installed by: Firm	
Name	
Warranty period..... months	
Date	Signature and stamp.....

Please read these instructions carefully before mounting and operating the actuator!

Preventive and safety-measures applied on the actuator can not offer required safety level till the actuator and its safety systems are not applied by required and described way and if installation and maintenance is not applied according to applicable instructions and rules!

Contents

1. General data	2
1.1 Purpose and applications.....	2
1.2 Safety instructions.....	2
1.3 Warning for safety use	3
1.4 Data specified on electric actuator.....	3
1.5 Guaranty Conditions	3
1.6 Under-guarantee and after-guarantee service.....	3
1.7 Operation conditions	4
1.8 Description	7
1.9 Basic specifications.....	10
1.10 Conservation, packing, transport, storing and unpacking.....	20
1.11 Assessment of the product and packaging and removal of contamination	20
2. Installation and dismantling of actuator	21
2.1 Installation.....	21
2.2 Dismantling	23
3. Adjusting of actuator	24
3.1 EA control set-up options (regulating)	27
3.2 Procedure for setting individual parameters and the register of errors and warnings.....	29
3.3 Putting an EA into operation when the EA is set up and connected with the armature already in the production plant (starting the calibration).....	32
3.4 Putting an EA into operation when the stroke and parameter setting done by the producer suit to your needs	33
3.5 Putting an EA into operation when it is necessary to do a change to the stroke (setting new end positions), and the other parameter setting done by the producer suits to your needs	33
3.6 Setting other parameters	34
3.7 Error messages from the control unit.....	34
4. Service and Maintenance.....	35
4.1 Service	35
4.2 Maintenance - extent and periodicity	36
4.3 Troubleshooting	37
5. Accessories and spare parts.....	39
5.1 Accessories.....	39
5.2 Spare part list.....	39
6. Enclosures.....	40
6.1 Wiring diagrams ES STR 1PA and STR 2PA for single phase supply.....	40
6.2 Wiring diagrams ES STR 1PA for three phase supply	41
6.3 Wiring diagrams ES STR 2PA for three phase supply	42
6.4 Wiring diagrams ES STR PA for three phase supply without reverse unit.....	43
6.5 Wiring diagrams ES STR 2PA – for three phase supply with-contactless switching.....	44
6.6 Wiring diagrams EA STR PA with interface Modbus/Profibus for single phase supply	46
6.7 Wiring diagrams EA STR 1PA with interface Modbus/Profibus for three phase supply.....	47
6.8 Wiring diagrams EA STR 1PA with interface Modbus/Profibus for three phase supply.....	48
6.9 Wiring diagrams ES STR PA – for three phase supply with-contactless switching.....	50
6.10 Dimensional drawings STR 1PA.....	53
6.11 Dimensional drawings STR 2PA.....	57
6.12 Commercial representation.....	64

The Installation, Service and Maintenance Instructions are drawn up according to requirements of EC Executive Nr. 2006/42/EC "Uniform requirements for machines and devices from the point of view of safety and health care", to save life and health of users and to avoid material damages and exposure environment to danger.

1. General data

1.1 Purpose and applications

Electric linear actuators **Rematic** (hereinafter referred as EA only) with the DMS 3 electronic control of the **STR 1PA and STR 2PA** type (hereinafter referred as STR PA only) are set up by the program to be controlled on the 24 V DC voltage level; are set up by the program to be controlled by analogue input signal, potentially controlled through a interface with **Modbus/Profibus** communication protocol.

Electric linear actuators **STR PA** types are high-powered electric-mechanical products designed for direct installations onto controlled devices (regulating bodies - valves, etc.). EA of STR PA types are provided for remote control of closing bodies, or for automotive control of regulating bodies in both directions of their movement. They can be equipped with means of measuring and control of technological processes where an unified analogue direct current resp. voltage signal is an information bearer on their input and/or output (not valid for EA's with Modbus/Profibus protocol). They are connected with the controlled devices with flanges according to DIN 3358 or using pillars and flanges.



1. It is forbidden to use EA as a lifting mechanism!

1.2 Safety instructions

1.2.1 Characteristics of the Product Regarding Its Exposure Rate



EA of **STR PA** types are reserved technical devices with higher rate of danger, with possibility of installation in areas specially danger regarding casualties caused by electric current. Electric actuators are according to directive LVD 2014/35/EU and standard EN 61010-1:2010+A1:2019 within valid edition assigned for installation category II (overvoltage category), pollution degree 2.

The product meets the essential safety requirements according to EN 60204-1 and is in compliance with EN 55011/A1 within valid edition.

1.2.2 Product influence to environment

Electromagnetic compatibility (EMC): the product complies with the requirements of the Directive 2014/30/EU of the European Parliament and of the Council on the approximation of the laws the Member States relating to the electromagnetic compatibility and with the requirements of standards as well EN IEC 61000-6-4, EN IEC 61000-6-2, EN IEC 61000-3-2 and EN 61000-3-3 in accordance with valid certificates.

Vibrations caused by the product: product influence is negligible.

Noise produced by the product: during operation the noise level A at the service area can be at least 78 dB (A) for STR 1PA and 80 dB (A) for STR 2PA.

1.2.3 Requirements for professional qualification of people performing installation, service and maintenance

Electric connection can be performed only by an acquainted person, i.e. an **electrical engineer** with professional education of electrical engineering at an apprentice school or a technical school (secondary, complete secondary or university education) and whose qualification was verified by an educational facility authorized to verify professional qualification.



1.2.4 Instructions for staff training



Service can be performed only by workers professionally qualified and trained by the producer or contracted service centre.

1.3 Warning for safety use

Product protection:

There must be included suitable protective device into the supply power (circuit breaker or fuse) which serves at the same time as main switch.

EA **STR PA** with three -phase has own short-circuit protection electronic circuits and space heater. There must be included suitable protective device into the supply power of 3-phase motor (circuit breaker or fuse) which serves at the same time as main switch.

Type of equipment from a connection point of view: The equipment is designed for permanent connection.

1.4 Data specified on electric actuator

Nameplate:

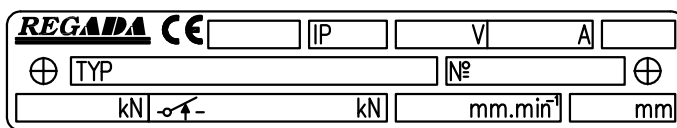

Warning plate:



Nameplate contains the basic data concerning identification, performance and electricity: indication of producer, type, serial number, load thrust and switching-off thrust, operating speed, protection code, operating stroke, supply voltage and current.

Graphic symbols on electric actuator

The graphic symbols used on electric actuator substitute the text messages. Some of them are in accordance with EN ISO 7010, ISO 7000 and IEC 60417 within valid edition.



Dangerous voltage

(EN ISO 7010-W012)

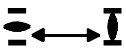

Stroke of the electric linear actuator



Switching-off thrust



Manual control

(0096 ISO 7000)



Protection terminal

(5019 IEC 60417)

1.5 Guaranty Conditions

The supplier is responsible for completeness of the delivery and guarantees proprieties of the product, stated by technical conditions (TC), or proprieties agreed upon on purchase contract.

The supplier is not responsible for product deteriorated proprieties caused by the customer during storing, non professional assembly, or non professional operation.

1.6 Under-guarantee and after-guarantee service

Under-guarantee service is performed by the service department of the production plant, or by a contracted service centre according to a written claim.

In case of occurring of any fault please let us know it and state:

- basic data from nameplate: type code and serial number
- type of fault - description of claimed fault (actuator employment, ambient parameters (temperature, humidity...), duty cycle including frequency of switching, type of switching-off (position or thrust),

set switching-off thrust, contact to the company implementing the installation and electric connection

- it is recommended to place also Installation certificate.

It is recommended to have **after-guarantee service** performed by the service department of the production plant, or by a contracted service centre. Serviceman makes the record about service mission after warranty actions and sends it to the production company.

1.6.1 Lifetime of actuators

The lifetime of an electric actuator (EA) is at least 6 years.

EA used for closing mode (closing valves) comply with the requirements for at least **15,000 working cycles** (cycle C – O – C: for linear EA).

EA used for regulating/modulating operation (control valves) comply with the below stated numbers of **operating hours** at the total number of 1 million start-ups:

Switching frequency				
max. 1,200 [h ⁻¹]	1,000 [h ⁻¹]	500 [h ⁻¹]	250 [h ⁻¹]	125 [h ⁻¹]
Minimal lifetime expectancy – number of operating hours				
850	1,000	2,000	4,000	8,000

Time of **net operation** is min. 200 hours, max. 2,000 hours.

Lifetime at operating hours depends on loading and switching frequency.

Note: High switching frequency does not ensure better regulation. Setting of regulation parameters should be therefore made with the inevitably necessary switching frequency needed for the process in question.

1.7 Operation conditions

1.7.1 Product location and operation position

- The assembly and operation of electric actuators in standard make can be on covered places of industrial objects without the regulation of temperature, humidity and with protection against direct exposure of climate influence (e.g. direct sun shine).
- Electric actuators must be placed with access to the manual handle, to the cover of control box, to control box, to cable glands and to local electric control.
- Installation and operation of actuators is possible in either position. Common position is the one with vertical position of exit part axis and control box above. Avoid to arrange the electric actuator under the armature if possible.

Warning:



Actuator installed on the open place must be protected against a direct climate effects by shelter, mainly from sunshine. In applications placed in an ambient of a relative moisture above 80%, in external ambient under shed, it is necessary to change the preset thermostat temperature +25°C to +70°C by a PC and program to prevent switching off the heating

resistor.

1.7.2 Operation Environment

According to valid standard IEC 60 721-2-1, there are delivered these versions of electric actuators:

- 1) Version „standard“ for type climate temperate
- 2) Version „tropical wet“ for type climate tropical wet
- 3) Version „cold“ - for type climate cold
- 4) Version „tropical dry and dry“ for type climate tropical dry and dry
- 5) Version „marine“ for type climate marine
- 6) Version „arctic“ for type climate arctic.

In accordance with IEC 60 364-1, IEC 60 364-5-51 within valid edition the EA have to resist external effects and operate reliably:

In the conditions of the following types of environment:

- warm mild to very hot dry with temperature in range -25°C to +55°C **AA 7***
- cold to warm mild and dry with temperatures in range -50°C to +40°C **AA 8***
- cold to mild hot dry with temperatures in range -60°C až +40°C **AA 1*+AA 5***
- with relative humidity 10 to 100 %, including the condensation of up to 0,029 kg water content per 1 kg of dry air, at above stated temperature **AB 7***
- with relative humidity of 15÷100%, including the condensation of up to 0,036 kg water content per 1 kg of dry air, at above stated temperature **AB 8***
- with relative humidity 5 to 100 %, including the condensation of up to 0,025 kg water content per 1 kg of dry, at above stated temperature **AB 1*+AB 5***
- with height above sea level 2 000 m, with barometric pressure range 86 to 108 kPa **AC 1***
- a possibility of partial or complete immersion - (products with protection enclosure IP x7) **AD 7***
- with submersion – (product with enclosure IPx8) **AD 8***
- with strong dustiness – with a possibility of influences of inflammable, non-conducted and non-explosive dust; the middle layer of dust; the dust drop more than 350 but not more than 1000 mg/m² per day (products with protection enclosure of IP 6x) **AE 6***
- with atmospheric appearance of corrosive and spoiling materials (with high degree of corrosive aggressiveness of the atmosphere; the presence of the corrosive spoiling materials is significant **AF 2***
- with permanent exposure of big amount of corroding or contaminated chemicals and salt fog in execution for sea environment , for sewage water disposal plant and some chemical plant.... **AF 4***
- with a possibility of influences of mechanical stress:
 - of mean sinusoid vibrations with frequency in range 10 to 150 Hz, with amplitude of shift 0,075 mm for $f < f_p$ and with amplitude of acceleration 9,8 m/s² for $f > f_p$; (contact frequency f_p is 57 to 62 Hz)..... **AH 2***
 - of mean sinusoid vibrations with frequency in range 10 to 150 Hz, with amplitude of shift 0,15 mm for $f < f_p$ and with amplitude of acceleration 19,6 m/s² for $f > f_p$; (contact frequency f_p is 57 to 62 Hz) – applies for 4 pillars version **AH 2***
 - medium impacts, shakings and vibrations **AG 2***
- growing of plants and moulds **AK 2***
- with strong danger of presence of animals (insects, birds, small animals) **AL 2***
- with harmful effects of radiation:
 - of escaping stray current **AM 2-2***
with intensity of magnetic field (direct and alternating of power supply frequency) to 400 A.m⁻¹
 - mean sunshine with intensity > 500 and ≤ 700 W/m² **AN 2***
- mean seismic effects with acceleration > 300 Gal ≤ 600 Gal **AP 3***
- with indirect danger of storm activity **AQ 2***
- with fast moving of air and strong winds **AR 3 , AS 3***
- with frequent contact of the staff with earth potential (persons often touch conductive parts or they stand on the conductive basement) **BC 3***
- without occurrence of dangerous media in the object **BE 1***

* Marking in accordance with IEC 60364-1, IEC 60 364-5-51 and IEC 60 364-5-55 within valid edition

1.7.3 Power Supply and Operation Modes

Power supply:

Electric motor..... 110/120 V AC, 220/230/240 V AC, 3x400 /3x380 V AC $\pm 10\%$, resp. 24 V AC $\pm 10\%$
(other - after agreement with manufacturer)

Controlbinary inputs 24 V DC $\pm 10\%$
.....input control signal 0/4/12 to 20 mA, 4 to 12 mA resp. 20 to 0/4/12 mA, 12 to 4 mA,
or 0/2 to 10 V, resp. 10 to 0/2 V

electronic positional transmitter (EPV) without power supply (passive)..... 18 up to 30 V DC $\pm 10\%$

communication protocol (by version)Modbus (either single Channel or duo Channel)

..... Profibus (either single Channel or duo Channel)

Frequency of power supply 50/60* Hz $\pm 2\%$

* *Operating speed at frequency 60 Hz is increasing 1.2 times and proportionally the value of loading thrust is decreasing.*

Duty cycle (according to EN (IEC) 60034-1 within valid edition):

EA STR PA are designed - **for remote control:**

- short-time operation S2-10 min
- intermitted operation S4-25%, 6 up to 90 cycles per hour

- **for automatic regulation:**

- intermitted operation S4-25%, 90 up to 1200 cycles per hour.

Note: *The operation modes consist of the loading type, load factor and connection/switching frequency.*

Warning: Non-compliance with operating mode may result in inactivation of the EA as a result of failure of the integrated thermal fuse (protection) of the electric motor.

1.8 Description

The **STR PA** electric actuator is controlled according to version

- by 24 V DC voltage fed to the electric actuator's terminals according to the wiring diagram, resp. by 0/4/12 to 20 mA, 4 to 12 mA (0/2 to 10 V))
- input control signal and provides for moving the output part of the EA automatically to a position corresponding to the value of the input signal) and other functions as well
- through Modbus reso. Profibus communication interface

The electric actuator consists of these main parts (**Fig. 1, 1A**):

The electric actuator is driven by an **electric motor (1)** supplied (single-phase motor) from the **source board (3)** and **control unit (2)** of the DMS 3 electronics.

Position of output element of EA and thrust is scanned by **contactless absolute sensor**. Depending on the version, the DMS3 electronic circuit board may include **an electronic position transmitter (EPV)** without power supply (passive) with output signal 4 through 20 mA.

Space heater (5) is placed at the control board.

In case of power cut or damage of switches the actuator can be controlled by **manual handle** according to instructions stated in **chapter 4. Service and Maintenance**.

Basic modules of DMS3 electronic control system for STR PA:

Control unit (2) – main part of system DMS3 – it contains microprocessor, 6 signal LED and 4 buttons for simple adjustment and control of EA, connectors for connection of thrust scanner and sourcing board and communication connector (connection to PC for adjustment and diagnostic), according to version 2 free programmable relays R1 and R2,, 1 relay READY and terminals for electric connection.

Sourcing board for single-phase version (**3**) – secures power supply of electronic and provides an output voltage of 24 V DC, 40 mA for the user, it contains user terminal board, switching circuits, connector for connection with control unit.

Position scanning unit (4) – secures contactless magnetic position scanning of output element.

Switching unit for 3-phase electric motors - reversing relays, contactors or contactless switching (SSR).

Thrust reading unit (6) – provides contactless magnetic thrust reading.

LED display (7) – shows instant position of EA output member and reports and displays potential errors, which would occur when EA is operated. Signalling motion and failure of the EA is also indicated by LEDs diode. LED display is used only pro type of construction EA without local control.

Manual control: made up by a handwheel with a worm gearing.

Other accessories – as optional accessories:

- **Module 3, or 6 additional relays (8).**
- Local electric control module equipped with 2-line LCD display (fig. 7).

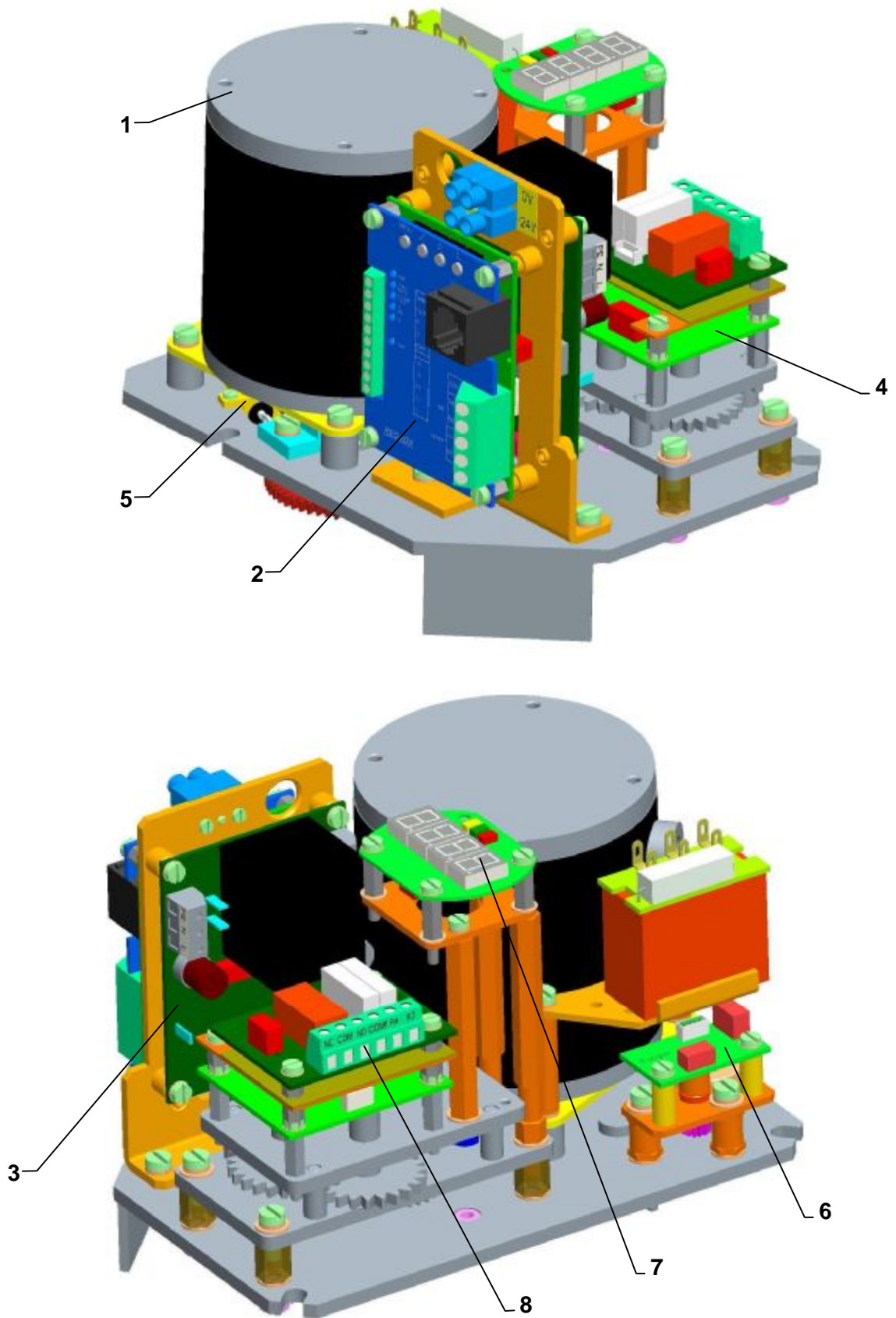

Fig. 1

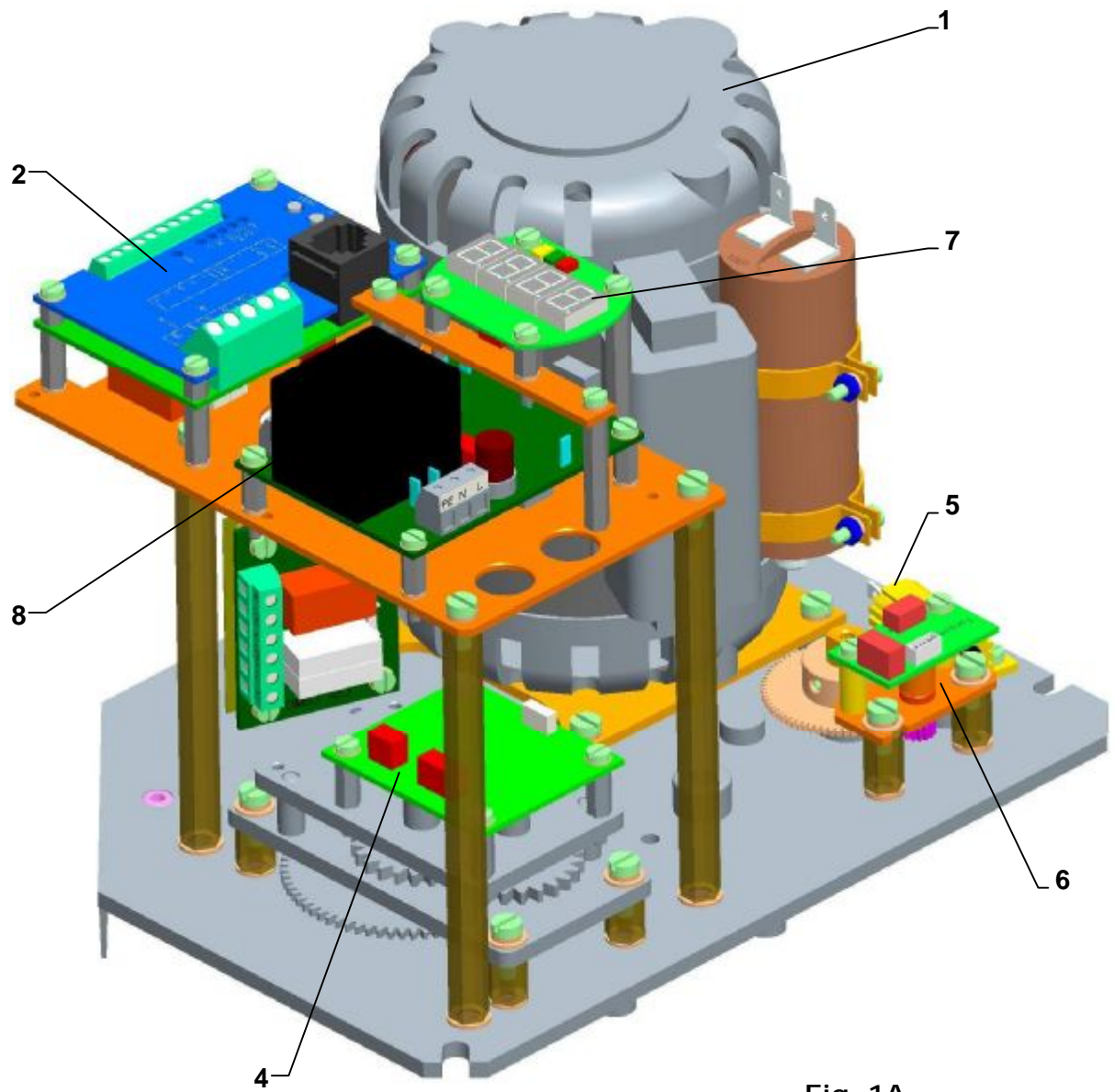

Fig. 1A

Type/ type number	Operating speed $\pm 10\%$		Operating stroke	Max. load thrust (regulation mode)	Max. load thrust (remote control)	Switching-off thrust $\pm 10\%$	Weight	Electric motor ²⁾					
								Supply voltage nominal voltage/frequency ²⁾	power	revolutions	current for	Capacitor capacity.	
	[mm/min]		[mm]	[N]	[N]	[N]	[kg]	[V] $\pm 10\%$	[W]	[1/min]	[A]	[μ F/V]	
	50Hz	60Hz											
STR 2PA, type number 492	10	12	110 - 20 resp. 20 - 80 resp. 20 - 100 (in accordance with version of mechanical connection)	21 500	17 200	19 000 - 25 000	17 - 21	Single-phase	120/60	25	1 680	0,80	20/250
				17 000	13 600	15 000 - 20 000			220/50	20	1 350	0,50	7/400
	14 000	11 200		12 000 - 16 000	230/50	20			1 350	0,50	7/400		
	21 500	17 200		19 000 - 25 000	240/60	25			1 680	0,36	5/450		
	17 000	13 600		15 000 - 20 000	Three-phase	3x400/ 3x380 AC			90	2 740	0,35	-	
	14 000	11 200		12 000 - 16 000									
	17 000	13 600		15 000 - 20 000									
	14 000	11 200		12 000 - 16 000									
	14 000	11 200		12 000 - 16 000									
	14 000	11 200		12 000 - 16 000									
	14 000	11 200		12 000 - 16 000									
	14 000	11 200		12 000 - 16 000									
	21 500	17 200		19 000 - 25 000									
	17 000	13 600		15 000 - 20 000									
	14 000	11 200		12 000 - 16 000									
	21 500	17 200		19 000 - 25 000									
	17 000	13 600		15 000 - 20 000									
	14 000	11 200		12 000 - 16 000									
	21 500	17 200		19 000 - 25 000									
	17 000	13 600		15 000 - 20 000									
	14 000	11 200		12 000 - 16 000									
	17 000	13 600		15 000 - 20 000									
	14 000	11 200		12 000 - 16 000									
	80	100		120	17 000	13 600		15 000 - 20 000					
100	120	145	14 000	11 200	12 000 - 16 000								
120	145		10 500	8 000	9 000 - 12 500								

1) For automotive regulation the operating speed 63mm/min is not recommended

2) Operating speed at frequency 60 Hz is increasing 1.2 times and proportionally the value of loading thrust is decreasing.

Other specifications:

EA protection enclosure: IP 67, IP 68 ((EN (IEC) 60 529 within valid edition))

According to definition for EA, enclosure IP68 fulfills following requirements:

- water column max. 10m
- time of continuous submersion in water max. 96 hours.

Mechanical ruggedness:

sinusoid vibrations see Chapter 1.7.2

resistance by drops..... 300 drops with acceleration of 5 m.s^{-2}

seismic resistance 6 degrees of Richter's scale

Self-locking: declared in range 0% to 100% of rated thrust

Motor's thermal protection: through thermo-contact

Electric control:

remote control - movement of output part of the electric actuator is controlled :

- by binary inputs 24 V DC, or
- by unified input signal 0/4/12 to 20 mA, 4 to 12 mA resp. 20 to 0/4/12 mA, 12 to 4 mA (0/2 to 10 V resp. 10 to 0/2 V), according to version
- potentially controlled through a interface with Modbus/Profibus communication protocol

Power supply of electronics:

- Power supply ZS is used for single phase and three phase versions and feeds the electronic modules built in EA.
- It provides the 24V DC, 40 mA output voltage (according to version).

Power sources contain a protective fuse with parameters according to chapter 1.9.2 Electric connection.

Position scanning:

- contactless absolute magnetic.

End positions adjustment:

End position relays are adjusted to the specified stroke with accuracy of $\pm 1 \text{ mm}$.

It is possible to set up (with buttons situated on the control unit, resp. with buttons situated on the local control, resp. program after connecting the EA with PC) the shutting off in end positions as follows:

- Z = Torque + O = Torque
- Z = Torque + O = Position
- Z = Position + O = Torque
- Z = Position + O = Position

Notes:

C = Torque - shutting off at end limit - thrust „Closed“

O = Torque - shutting off at end limit - thrust „Opened“

C = Position - shutting off at end limit - position „Closed “

O = Position - shutting off at end limit - position „Opened“

Factory's setup of shutting off in end positions is described in the chapter "Adjusting of actuator".

Thrust scanning: - contactless absolute magnetic.

Switching-off adjusting:

Disengaging thrust is factory adjusting to a maximum value with the $\pm 15 \%$ tolerance shown on the nameplate of the appropriate EA.

The user is allowed to modify the switching-off thrust value within the range 50 - 100%, stepped by 10%.

Thrust blocking:

The switching-off from thrust can be blocked within a certain range of the stroke starting from a stroke end position (max..5%), for time agreed on, in range of 0 to 20 sec..

Output relay (according to version) :

- 3x relays (standard) (standard for DMS3 without version Modbus/Profibus) (**READY, R1, R2**) max. 250 V AC/1 A/cos phi=1; max. 30 V DC/2A

- 3x additional relays (options) (**RE3, RE4, RE5**) max. 250 V AC/1 A/cos phi=1; max. 30 V DC/2A
- 6x additional relays (options) (**RE1, RE2, RE3, RE4, RE5, READY**) max. 250 V AC/1 A/cos phi=1; max. 30 V DC/2A
- relays are free programmable (their function can be changed with buttons on the control unit, with buttons on the electric local control, or through a PC with the program).

READY relay: - programme selections option – error indication, error or warning, error or not remote, error or warning or not remote. READY relay factory set is shown in the “Adjusting of actuator” Chapter. Relay READY on the control unit and supply unit are doubled (it is not possible to set different functions on these units).

R1, R2, RE1, RE 2, RE3, RE4 and RE5 relay: - programme selections option – disabled, Position O (position open), Position C (position close), Torque O (thrust open), Torque C (thrust close), Torque O or Torque C, Torque O or Position O, Torque C or Position C, opens, closes, movement, movement – flasher, to position, from position, warning, control – remote, control – local, (not valid for EA without local control), control OFF.

Relay R1 is doubled with relay RE1 and relay R2 is doubled with relay RE2 (it is not possible to set different functions on these units).

RE3, RE4, RE5 relays are independent. Factory setting up of the individual relays is shown in the “Adjusting of actuator” Chapter.

Transmitter (output signal) (not valid for Modbus/Profibus version)

Electronic position transmitter (EPV) passive (for single phase versions)- 2-wire connection

(without inbuilt power supply)

Current signal	4 ÷ 20, resp. 20 ÷ 4 mA (DC)
Voltage at connection of EPV passive	18 up to 30 V DC
Load resistance	max. $R_L = 500 \Omega$
Tolerance of value of output signal of electronic transmitter in end positions:	$\pm 0,5 \%^{1)}$
Tolerance of linearity of transmitter.....	$\pm 1 [\%]^{1)}$
Hysteresis of transmitter	max. 1 [%] ¹⁾

1) from nominal value of transmitter referred to output values

Galvanic separation..... output signal is galvanically separated from input control signal

Program possibilities of output signal : 4 ÷ 20 mA, 20 ÷ 4 mA. Factory's setup of output signal is described in the chapter “Adjusting of actuator”.

Electronic position controller (N) (not valid for Modbus/Profibus version)– actuation by input control signal

Input control signals - analogue:	0 - 20 mA (0 – 10 V according to version)
.....	4 - 20 mA(2 – 10 V according to version)
.....	12 - 20 mA
.....	4 - 12 mA
.....	20 - 0 mA(10 – 0 V according to version)
.....	20 - 4 mA(10 – 2 V according to version)
.....	20 - 12 mA
.....	12 - 4 mA

Input resistor for signal 0/4 up to 20 mA..... $R_{in} = 120 \Omega$

Input resistor for signal 0/2 up to 10 V..... $R_{in} = 30 k\Omega$

Tolerance of controller's linearity: 0,5 %

Dead of controller: program adjustable within 1 - 10%

Factory's setup of input signal is described in the chapter “Adjusting of actuator”.

Version with Modbus interface:

- Modbus, line specification: RS485, two-wire design, half duplex.
- Modbus, Transmission Mode: RTU (8-bit binary data).
- Variants:
 - Single Channel version with cable or component redundancy or with repeater (common address and communication parameters).
 - Duo Channel version with cable or component redundancy or with repeater (common address and communication parameters).
- Address: 1 through 247
- Parity:
 - Even (1 stop bit)
 - Odd (1 stop bit)
 - No (2 stop bits)
- Supported transmission rates:
 - 300 bit/s
 - 600 bit/s
 - 1200 bit/s
 - 2400 bit/s
 - 4800 bit/s
 - 9600 bit/s
 - 19200 bit/s
 - 38400 bit/s
 - 57600 bit/s
 - 115200 bit/s
- Signal delay (repeater):
 - max. 2.67 μ s
- Bit edge reduction/extension (repeater):
 - max. 1.67 μ s

Version with Profibus interface:

- Profibus, line specification: two-wire design, galvanic separated.
- Variants:
 - Single Channel version.
 - Duo Channel version (simple/redundancy).
- Address 1: 1126
- Address 2: 1126
- Redundancy:
 - Off (for single channel version)
 - Simple (for duo channel version)
- Supported transmission rates:
 - 9,6 kbit/s
 - 19,2 kbit/s
 - 93,75 kbit/s
 - 187,5 kbit/s
 - 500 kbit/s
 - 1500 kbit/s

Control by binary inputs 24 V DC:

- by feeding of 24 V DC to terminals **CLOSE** and **OPEN**

Programming possibilities of binary inputs I1 and I2 (change is possible only through the programme of PC or using buttons local control)

- for the input **I1** : DISABLED; ESD; DBL (local releasing - not valid for EA without local control), STOP
 - for the input **I2** : DISABLED, ESD; DBL (local releasing - not valid for EA without local control), 2P 2P resp. E2P (the EA can undergo control for the opening direction or closing with the controller ON and I2 input activated with 24 V DC voltage supplied to the terminals to OPEN or CLOSE).
- Factory's setup is described in the chapter "Adjusting of actuator".

Programmable FAILURE REACTION : OPEN, CLOSE, STOP, SAFE POSITION

Factory's setup is described in the chapter "Adjusting of actuator".

Adjustable elements of electronics:

The EA is possible to adjust with or resetting to different parameters operating the control unit buttons, or with buttons on the local control (according to version), or once it is connected to the PC using the programme and the communication cable connected to the EA control unit communication connector and the EA cover removed.

Space heater (E1)

Space heater - supply voltage:corresponding with motor supply voltage (max. 250 V AC)

Space heater power output:: STR 1PA cca 10 W/55°C

Space heater power output:: STR 2PA cca 20 W/55°C

Electronic board provides switching of heating element. It is possible to change switching temperatures of the switch from -40°C to $+70^{\circ}\text{C}$ with help of PC and particular software. Factory's setup for shut down of heating element (thermostat) is $+25^{\circ}\text{C}$.

Manual control:

- with manual handle on the upper cover of the EA. Turn the manual handle clockwise to move the output shaft of the EA in the direction "Z – closed".

Output part clearance: max. 0, 5 mm (typical value 0,2mm) at 5 % of maximum thrust load)

Grease: see chapter 4.2 Maintenance - extent and periodicity.

1.9.1 Mechanical Connection

Main and connecting dimensions are given in the **dimensional drawings**.

1.9.2 Electric connection**To the terminal board (X, X1, X2) for DMS 3 electronic control:**

- 3 terminals (PE, N, L) on the sourcing board with cross-section of connection wire 0,05 - 1,5 mm² for solid wire and for flexible wire. Max. terminal screw tightening torque 0,5 N.m
- 3 terminals ((2(L1), 3(L2), 4(L3)) – for version with 3- phase electric motor) with intersection of connection wire max. 1,5 mm² . Max. terminal screw tightening torque 0,285 N.m.
- 4 terminals ((5,6,OP,CL) – for version with 3- phase electric motor without reverse unit) with intersection of connection wire max. 1,5 mm² . Max. terminal screw tightening torque 0,285 N.m.
- 2 terminals (0 V,+24 V) with cross-section of cross-section wire max. 1,5 mm² Max. terminal screw tightening torque 0,285 N.m.
- 5 terminals (READY, R1, R2) with cross-section of connection wire 0,05 – 1,5 mm² for solid wire and for flexible wire. Max. terminal screw tightening torque 0,5 N.m
- 10 terminals (COM, CLOSE, OPEN, I1, I2, +IN,-IN,SH,+L,-L) with cross-section of connection wire 0,05 – 1 mm² for solid wire and for flexible wire. Max. terminal screw tightening torque 0,19 N.m.
- 6 terminals (COM1, RE3, RE4, COM5, NO5, NC5) - for module 3 additional relays with cross-section of connection wire 0,05 – 1,5 mm² for solid wire and for flexible wire. Max. terminal screw tightening torque 0,5 N.m.
- 11 terminals (COM1, RE1, RE2, RE3, RE4, COM5, NO5, NC5, COM, NO, NC - for module 6 additional relays with intersection of connection wire 0,05 – 1,5 mm² for solid wire and for flexible wire. Max. terminal screw tightening torque 0,5 N.m.

To the terminal board (X3) for DMS3 with MODBUS protocol:

Terminal boards with spring connection are used, with cross-section of connection wire 0,08 to 2,5 mm²

- 3 terminals (PE, N, U) – supply voltage for version with single - phase electric motor
- 5 terminals (PE, N, U, V, W) – voltage for version with three - phase electric motor
- 2 terminals (21, 22) – voltage for the 24 V DC control
- 10 terminals (13,14,15,16,17) – terminals for the 24 V DC control (COM,CLOSE,OPEN, I1, I2)
- 6 terminals (1,2,3,4,5,6) – terminals single Channel interface of version Modbus/Profibus
- 6 terminals (7,8,9,10,11,12) – terminals duo Channel interface of version Modbus/Profibus
- 3 terminals (18,19,20) – module relay READY (by version)
- 5 terminals (18,19,20,23,24) – module additional relays (by version)

Attention: Thermic resistance incoming wires must be minimum +80°C

Wire cross-section conversion table (mm ² – AWG)	
Wire cross-section	
mm ²	AWG
0,05	30
0,2	24
0,34	22
0,5	20
0,75	18
1,5	16
2,5	14
Tightening torque conversion table (N.m – lbs.-in)	
Tightening torque	
N.m	lbs.-in
0,2	2,7
0,3	4
0,5	7

Cable glands for EA with the DMS 3 electronic control

STR 1PA

Cable glands for the model without electric local control:

- 3-cable cable glands – 1xM12 - diameter of cable 3,5 to 5 mm, 1xM16 - diameter of cable 9 to 13 mm (extended) and 1xM20 - diameter of cable 8 to 14,5 mm

Cable glands for the model with electric local control:

- 2-cable cable glands – 1xM12 - diameter of cable 3,5 to 5 mm and 1xM16 - diameter of cable 9 to 13 mm

STR 2PA

Cable glands for the model without electric local control:

- 3-cable cable glands – 1xM16 - diameter of cable 6 to 10,5 mm, 1xM16 - diameter of cable 9 to 13 mm (extended) and 1xM20 - diameter of cable 8 to 14,5 mm

Cable glands for the model with electric local control:

- 2-cable cable glands – 1xM16 - diameter of cable 6 to 10,5 mm and 1xM16 - diameter of cable 9 to 13 mm (extended)

Cable glands for EA with the DMS 3 electronic control with Modbus/Profibus protocol

- 2 cable glands M20x1,5, cable diameter 8 to 14,5 mm
- 2 resp. 4 cable glands EMC M16x1,5 - cable diameter 6,5 to 9,5 mm, diameter of shielding 2,5 to 6mm.

Protection terminal:

During start-up - during installation of device:

- outside and inside ground terminal must be connected for safe operation of the actuator. The position of the outside and inside ground terminal can be seen in **Fig. 2 2a, 2b, 2c, 2d**. For forcing - in wires in external ground terminal be needed use pliers HP3 for insulated eyelet (firm CEMBRE).
- a switch / circuit breaker must be installed on the power supply line, as close as possible to the device, easily accessible to operators and identified as the actuator isolation switch.

External and internal, are together connected and marked with the mark of protection grounding.

The electric connection should be made according to wiring diagrams pasted into the upper cover resp. terminals box of the EA.

Fuses:

Actuator power supply board is installed with power supply fuse (F3). Location of the fuse on the power supply board can be seen in Fig.2.

ES equipped with a contactless switching module (SSR) are additionally secured by fuses (F4-1 and F4-2) on the bracket (Fig. 2e).

Fuse values and parameters:

Product	Order code	Voltage	Frequency (Hz)	Motor Power / Input (W)	max. Current EA (A)	Fuse F3 value	Fuse value only for version with SSR) F4-1 F4-2
STR 1PA 431	431.1-0XXXX/YY	230 VAC	50	15/39 18/48	0,3	F 2,5 A / 250 V	-
	431.1-LXXXX/YY	220 VAC	50				-
	431.1-VXXXX/YY	240 VAC	60				-
	431.1-TXXXX/YY	120VAC	60				-
	431.1-3XXXX/YY	24 VAC	50				-
	431.1-JXXXX/YY	24 VAC	60	2,8	T 3,15 A / 250 V	-	
	431.1-NXXXX/YY	3x380 V	50	15/40	0,25	F 2,5 A / 250 V	FF 3,15A/500V
	431.1-2XXXX/YY	3x400 V	50	15/40	0,25		
STR 2PA 432	432.1-0XXXX/YY	230 VAC	50	20/75	0,45	F 2,5 A / 250 V	-
	432.1-LXXXX/YY	230 VAC	50	25/70			-
	432.1-TXXXX/YY	120 VAC	60		1,0	F 2,5 A / 250 V	-
	432.1-0XXXX/YY	230 VAC	50	60/120	0,9	F 2,5 A / 250 V	-
	432.1-TXXXX/YY	120 VAC	60	70/125	1,3	F 2,5 A / 250 V	-
	432.1-FXXXX/YY	3x380 V	50	90/150	0,5	F 2,5 A / 250 V	FF 3,15A/500V
	432.1-NXXXX/YY	3x380 V	50	90/150	0,5	F 2,5 A / 250 V	
	432.1-EXXXX/YY	3x400 V	50	90/150	0,5	F 2,5 A / 250 V	
432.1-2XXXX/YY	3x400 V	50	90/150	0,5	F 2,5 A / 250 V		

INTERNAL
PROTECTION
TERMINAL FOR
SINGLE PHASE
VERSIONS

FUSE SUPPLY (F3)

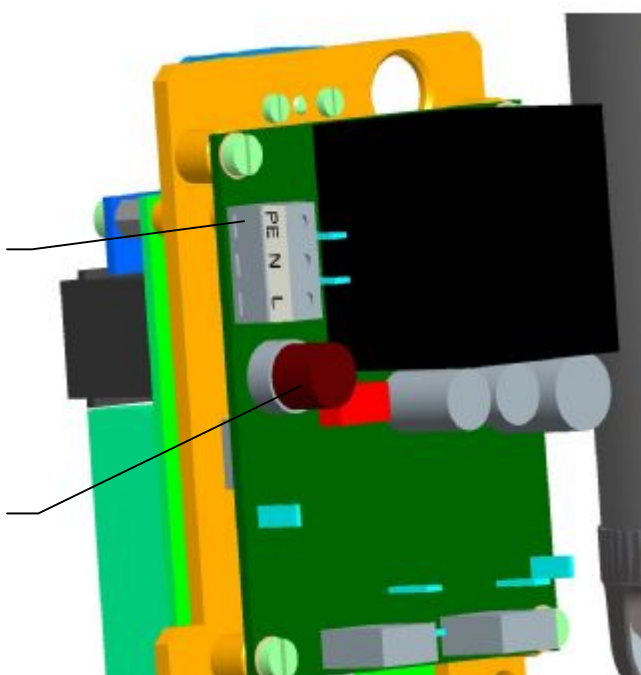

Fig.2

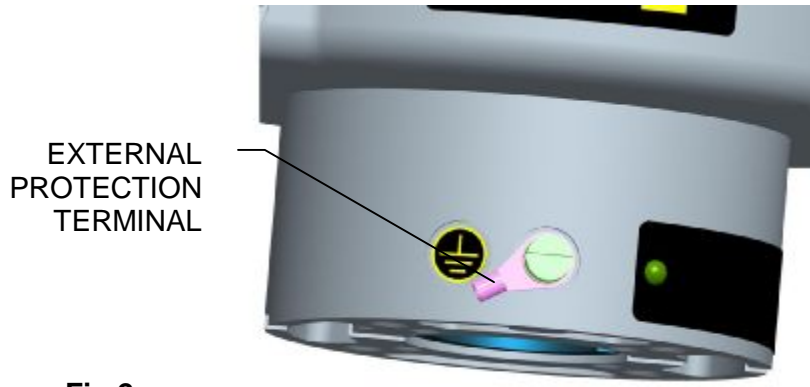

Fig.2a

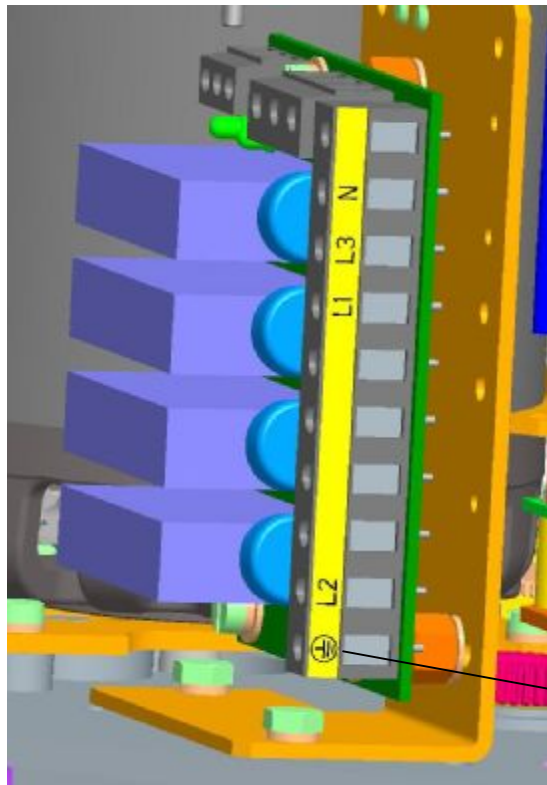

Fig.2b

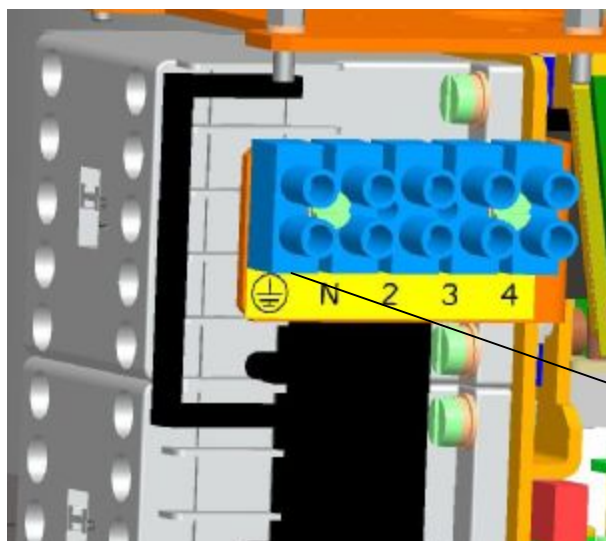
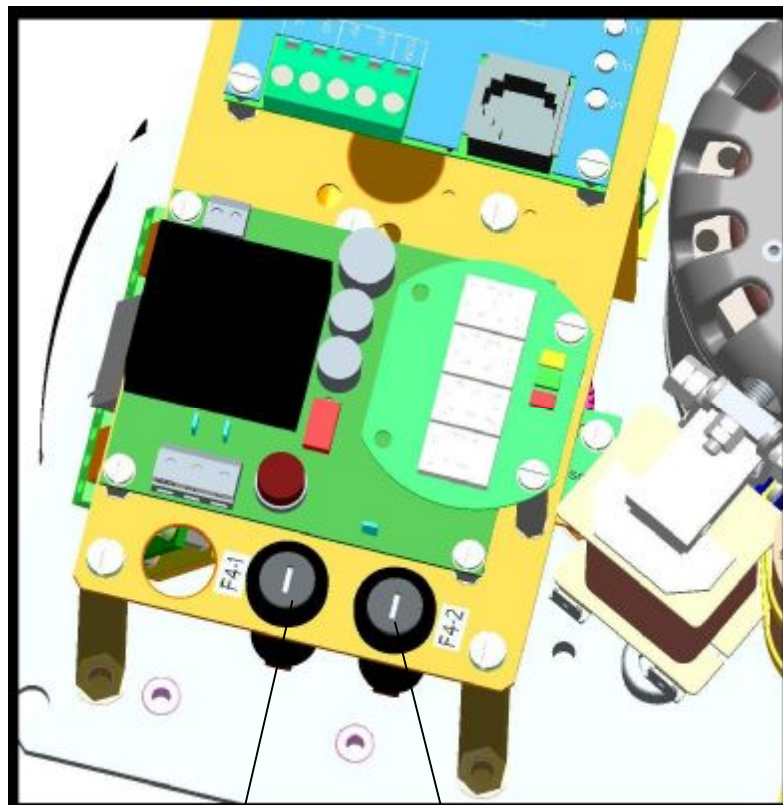
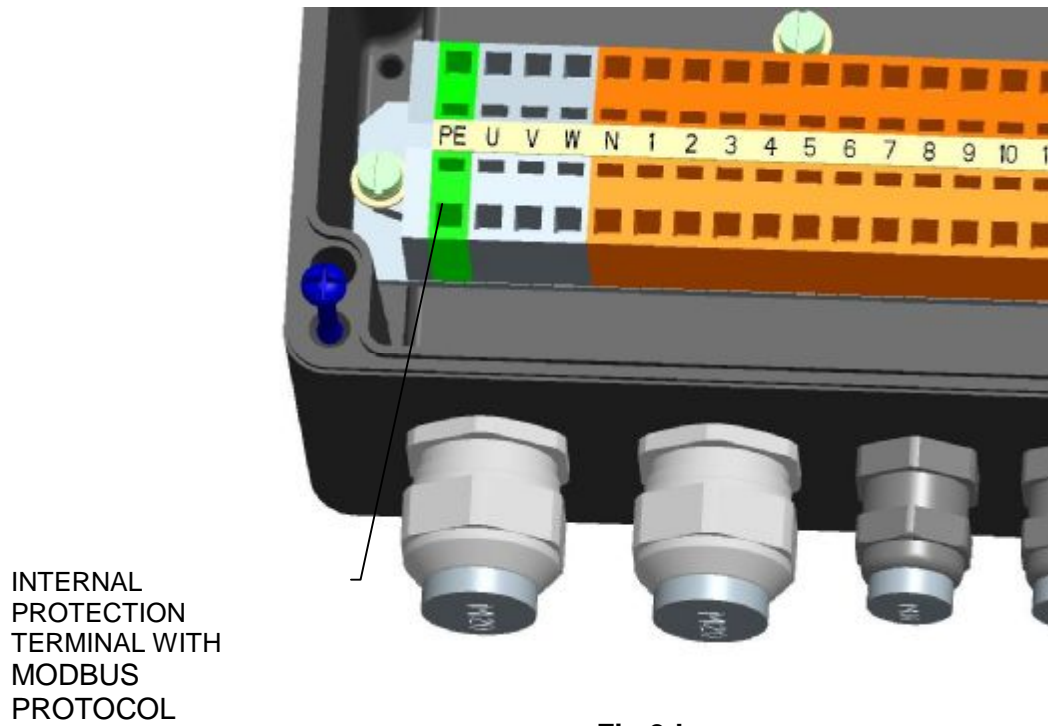

Fig.2c



FUSE F4-1

FUSE F4-2

1.10 Conservation, packing, transport, storing and unpacking

Surfaces without surface treatment are treated by conservation preparation MOGUL LV 2-3 before packaging .

Conservation is not necessary if the following storage conditions are complied with:

- Storage temperature: -10 to +50 °C
- Relative air humidity max.80 %
- Electric actuators and their accessories must be stored in dry, well ventilated covered spaces, protected against impurities, dust, soil humidity (by placement to racks, or on palletes), chemicals and foreign interventions
- There shall be no corrosive gases present in the storage areas.

The EA are delivered in solid packages guaranteeing resistance in accordance with EN (IEC) 60 654. Package is a box. Products in boxes is possible to load on the pallets (pallet is returnable). On the outer side of the package is stated:

- manufacturer label,
- name and type of product,
- number of pieces,
- other data – notices and stickers.

The forwarder is obliged to secure packed products, loaded on transportation means, against self-motion; if open transportation means are used, to secure their protection against atmospheric precipitations and splashing water. Displacement and securing of products in transportation means must provide their stable position, exclude the possibility of their inter-collision and their collision with the vehicle walls.

Transportation can be executed by heatless and non hermetic spaces of transportation vehicles with influences within the range:

- temperature: -25° C up to +70° C (a strange version – 45 ° C up to + 45 ° C)
- humidity : 5 up to 100 %, with max. water content 0.029 kg/kg of dry air
- barometric pressure 86 up to 108 kPa.

Upon receiving of EA examine, if during transportation, resp. storing did not come to its damage. At the same time verify, if the data on the labels corresponds to accompanying documentation and purchase-sale contract / order. Eventual discrepancies, faults and damages should be reported without any delay to supplier.



Electric actuators and their accessories must be stored in dry, well ventilated covered spaces, protected against impurities, dust, soil humidity (by placement to racks, or on palletes), chemicals and foreign interventions, at ambient temperature from -10°C up to +50°C and at relative air humidity max. 80 %.

It is not acceptable to store EA outdoors, or in areas not protected against direct climate influence!

Eventual damages to surface finish remove without delay – thus preventing damage by corrosion.

If storing takes longer than 1 year, it is necessary to inspect lubrication fillings before putting EA into operation and in case of need perform maintenance.

Assembled EA, but not put into operation is necessary to protect by the equivalent method as during storage (for example suitable protective cover).

After assembly to the armature in free and wet areas, or in areas with temperature changes, connect without delay heating resistor – thus preventing damages caused by corrosion from liquefied water in the control area.

Excessive preserving grease remove just before putting EA into operation.

1.11 Assessment of the product and packaging and removal of contamination

The product and its package are made of recycling materials. Do not throw the single parts of the package and of the product after their life but sort them according to instructions in corresponding executives or regulations of environment protection, and allow their recycling.

The product and its packing are not a source of any environment pollution or contamination and do not contain any dangerous waste.

2. Installation and dismantling of actuator

2.1 Installation



Abide by safety measures!

Note: Check again whether the EA is placed in accordance with the Chapter "Operation Conditions". If the installation conditions are different than recommended it is needed to consult the situation with the producer.

Before starting of mounting the EA onto the valve:

- Check again whether the EA was not damaged during storing.
- Check whether the adjusted operating stroke and connecting dimensions of the actuator (see the nameplate) are in compliance with the valve parameters.
- In case of inconsonance, perform adjusting according to the part Adjusting of actuator.

2.1.1 Mechanic connection of electric actuator to the armature

EA is by the producer adjusted to parameters according to the nameplate, with connecting dimensions according to the corresponding dimensional drawing and put it to a mid-position.

Before installation put the hand wheel on.

Mechanical connection with connection dimensions according to DIN (Fig.3)

- Properly defat contact surfaces of the EA connecting flange and the valve.
- Check the nameplates to assure that actuator and valve strokes are the same.
- Set the actuator (A) and the valve (B) to the position "closed".
- Put the actuator (A) onto the valve (B) to have the actuator shaft (3) lean onto the valve coupling (8).
- Turn the valve output shaft (5) to connect the stem with the valve output shaft having the actuator flange (2) sitting on the valve flange (7).
- Tighten the screws (4) with the cross system to connect the actuator flange (2) with the valve flange (7).
- Check connection dimensions in accordance with Fig. 1.
- Turn the valve output shaft (5) by one revolution and lock it with the nut (6) (to create pre-stressing against the valve seat).

A ... electric actuator

- 1 ... hand wheel
- 2 ... actuator flange
- 3 ... shaft

B ... valve

- 4 ... screw
- 5 ... valve output shaft
- 6 ... locking nut
- 7 ... valve flange
- 8 ... valve coupling

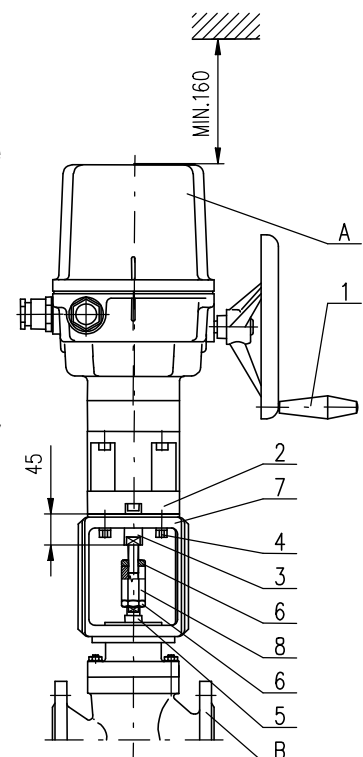

Fig. 3

Mechanical connection for pillar versions with flanges of A, B, C and D types (Fig.4)

- Set the actuator (A) and the valve (B) to the position "closed".
- Loosen and unscrew two screws (5) on the actuator shaft (3) and disconnect the coupling clamping parts (8)
- Screw the coupling nut (8) onto the valve output shaft (6) (max. 28mm) to have an allowance between the coupling nut (9) and the actuator shaft (3) after the actuator is sat on.
- Place the actuator (A) onto the valve (B) and fix the actuator slightly with the screws (4a), or with the central nut (4) (according to shape of connecting flange of EA) in the way you be able to move it.
- By turning hand wheel (1) move end shaft EA (3) toward thread coupling (8) screwed onto valve output shaft (6) (or unscrew thread coupling)
- Put the clamping parts of the thread coupling (8) on, and tighten the both coupling screws (5) to have the coupling nut able to rotate
- Tighten the screws (4a), or central nut (4) with the cross system to fasten the actuator (2) and valve (7) flanges.
- Check the connection diameters in accordance with the Fig. 2.
- Unscrew the coupling nut (8) by one more revolution (to create the pre-stress against the valve seat), and tighten the coupling screws (5) firmly

Notes:

1. *Minimum mechanical ruggedness of screws is 8G.*
2. *If adjustment of the position-signalling unit or the transmitter in the production plant do not correspond with the EA connected this way, adjust the units.*

In the end of mechanical connection check correctness of the connection with the valve with rotating the hand wheel.

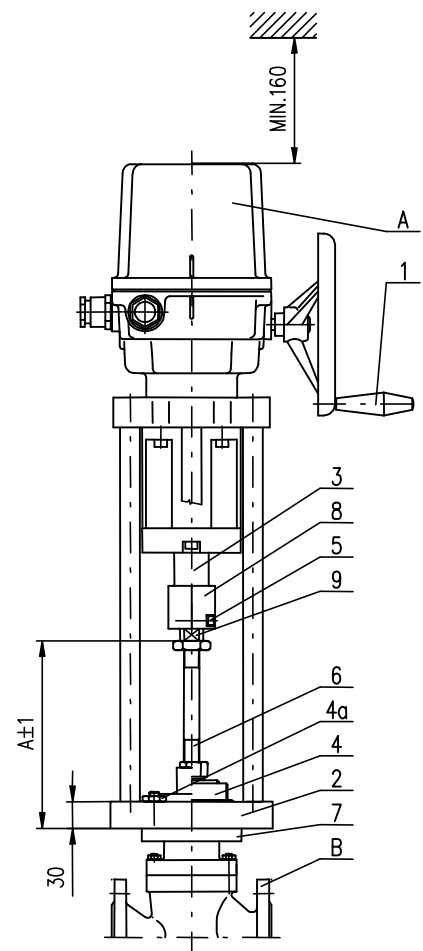

Fig.4

A electric actuator

- 1 hand wheel
- 2 actuator flange
- 3 shaft
- 4 central nut
- 4a screw
- 5 screw

B ... valve

- 6 valve output shaft
- 7 valve flange
- 8 coupling

2.1.2 Electric connection and checking of function

Follow up with connecting the EA with mains or master system.



1. Follow instructions in the part "Requirements for professional qualification"!
2. While laying electrical line abide by the instructions for heavy current installations. Power supply cables must be of the type approved. Minimum thermal resistance of power supply cables and wires must be +80°C.
3. Cables to terminal boards or connectors lead through cable glands.
4. Before putting EA into operation it is necessary to connect inside and outside grounding terminal.
5. Wires of input control signals to controller and output signals from current converter it is necessary to lead them separately with thrust wires or it is necessary to use shielded wires.
6. To prevent moisture from entering the actuator around the connecting cables, the cables must be sealed with silicone material at the point of penetration through device shell.

Connecting with the master system:

EA can be controlled by: - by analogue signals through the built-in controller
- by binary inputs 24 V DC

EA is connected according to wiring diagram under the cover of EA.

Notes:

1. Wires of input control signals to controller and output signals from current converter it is necessary to lead them separately with thrust wires or it is necessary to use shielded wires.
2. Together with EA are delivered sealing cable glands which make possible enclosure protection IP68 in case of tight mounting onto supply lead. For required enclosure it is necessary to use rings according to real diameter of cable and required thermal resistance.
3. When fastening the cable it is necessary to count with allowable diameter of bending so it will not be damaged or there will not be deformation of sealing element of cable bushing. Supply cable have to be fastened to solid construction furthest 150 mm from cable glands.
4. Sealing areas of cover of the control part have to be clean before repeated fastening.
5. Reversion of EA is guaranteed when time interval between switch-on and switch-off the power supply for reverse direction movement of output part is min. 50 ms.



In version **STR PA** it is necessary to do **autocalibration** in operation according by enclosure assure the optimal function.



Abide by instructions of valve producers, whether switching-off end positions is to be realised with position or thrust!

2.2 Dismantling



**Before dismantling it is required to disconnect the EA from power supply!
Do not connect and disconnect live connectors!**

- Disconnect the EA from mains phases.
- Disconnect the leads from the EA terminal boards and loosen the cables from cable glands.
- Loosen the fixing screws of the EA flange and of the coupling and disconnect the EA from the valve.
- While sending the EA to be repaired put it into a package solid enough to avoid damages of the EA during transportation.

3. Adjusting of actuator



Attention! See the Chapter 1.2.3 Requirements for Professional Qualification ...
Keep safety regulations!

EA are delivered adjusted onto parameters according to nameplate from Production plant.

Adjustment is made onto mechanical and electrical connected actuator. This chapter describes how to set up the EA to parameter values within a range applicable for the software. Location of adjustable parts of control board is on **Fig. 6 and Fig.6a**.

Adjusting is possible:

- by operating the control unit buttons (see **Fig. 6) and Fig.6a)**
- by operating the local control panel buttons (see **Fig. 7)** – only for the EA s equipped with local control;
- through the programme once the EA is connected to the PC using the communication cable.

For the specific adjustment procedure or individual parameters reset see individual appendixes **74 1053 02, 74 1076 02**.

For facilitating the simple setting of required operation parameters, the control unit is equipped with :

- four setting buttons: **MENU, P, O, C**
- six signal lamps according (LED diode) to **Fig. 6 and Fig.6a)**

Status indication by means of LED diodes:

LED ERROR (red) – blinks red in case of failure eventually lights in the parameter setting mode

LED OPEN / MENU (green) – in the ON/OFF mode it lights with a control action for the **opening** direction eventually blinks with accessing the MENU mode

LED CLOSE / PAR (red) – in the ON/OFF mode it lights with a control action for the closing direction eventually blinks besides the chosen parameter in the menu and lights up at writing the parameter into the memory

- **LED I1 / SEL** (yellow) – permanent lights with active input I1, or flash in the mode of parameters set up.
- **LED I2** (yellow) – permanent lights with active input I2
- **LED POWER** (green) – it light on at leading the power supply.

For version with Modbus communication

- **LED DEX1** (yellow) – permanent lights during Modbus single Channel communication
- **LED DEX2** (yellow) – permanent lights during Modbus duo Channel communication.

more LED for Profibus version

LED DEX1/ERR (yellow/red) - Profibus chanel 1

yellow - permanent lighting by active communication, chanel in DATA Exchange mode

red - permanent lighting by faulty communication, chanel is not in DATA Exchange mode

red - blinking by Fatal Error (necessary to restart an actuator - switch-off and afterthen switch on)

LED DEX2/ERR (yellow/red) - Profibus chanel 2

yellow - permanent lighting by active communication, chanel in DATA Exchange mode

red - permanent lighting by faulty communication, chanel is not in DATA Exchange mode

red - blinking by Fatal Error (necessary to restart an actuator - switch-off and afterthen switch on)

Electronics - programme selections option according to version

- **relay R1; R2; RE1 to RE5** : disabled; open position, close position, torque-open, torque – close, torque open or torque close, torque open or position open, torque close or position close, open, close, movement, movement flasher, to position, from position, warning, remote control, local control, control shut off, relé READY.

- **relay READY**: errors, errors or warnings, errors or no remote, errors or warnings or no remote.
- **output signal** (from EPV passive): 4 to 20 mA; 20 to 4 mA.
- **control (regulating)**: 2P, 3P, 3P/2P I2
- **input control signal (N)**: 4 to 20 mA, 20 to 4 mA, 0 to 20 mA, 20 to 0 mA
- **input I1**: DISABLED, ESD, DBL (local releasing - not valid for EA without local control), STOP
- **input I2**: DISABLED; ESD; DBL (local releasing - not valid for this type of the EA), 2P resp. E2P (for control programme option 3P/2P I2, or in case of active communication through Modbus/Profibus protocol, allows control using the binary 24V DC inputs with I2 input activated).
- **FAILURE REACTION**: OPEN, CLOSE, STOP, SAFE POSITION

The identical functions cannot be set on **I1 & I2** inputs in addition to the OFF state (e.g., if the ESD function is set on I1 input, it is not possible to select the ESD function on I2 input at the same time).

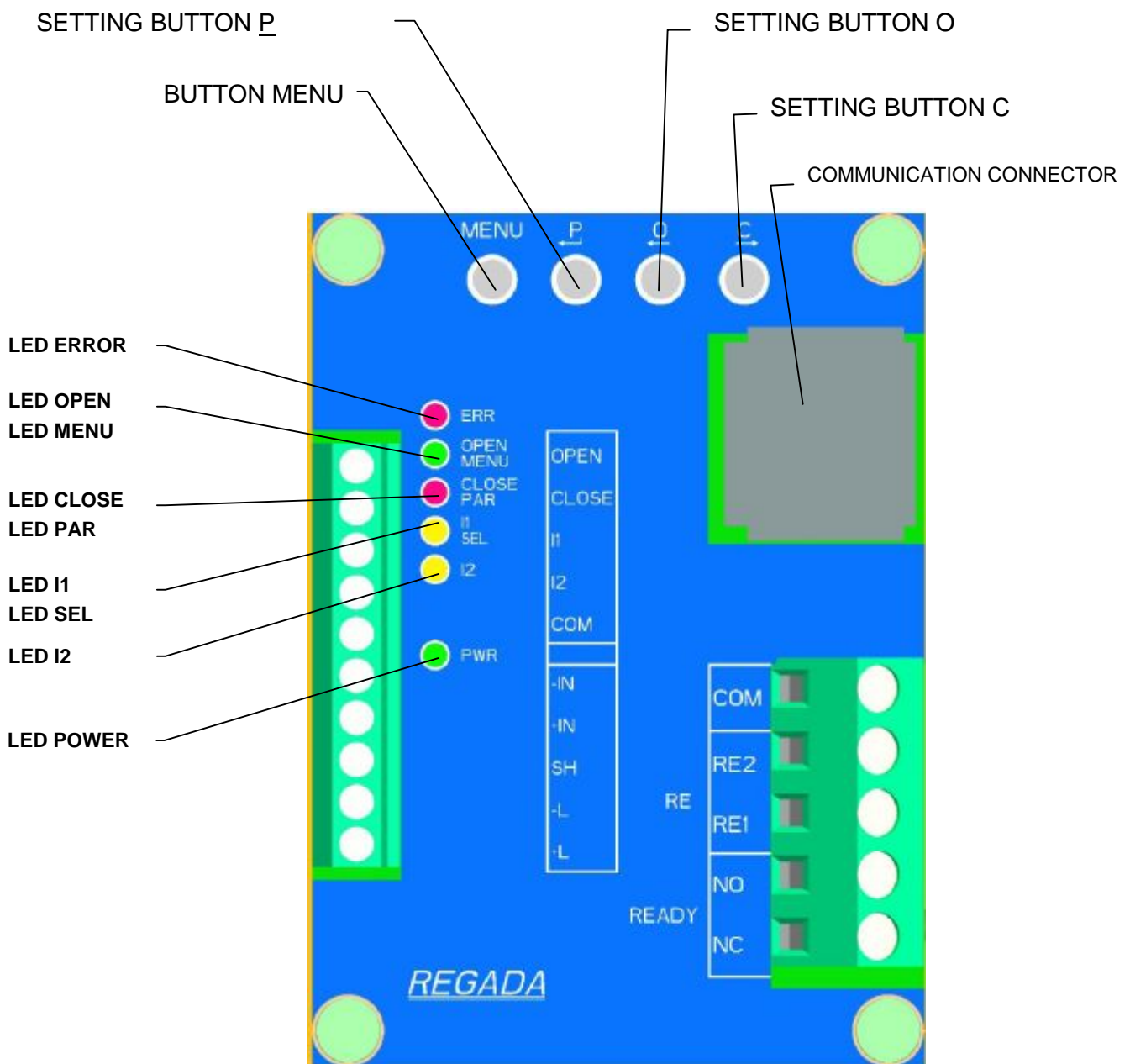

Fig. 6

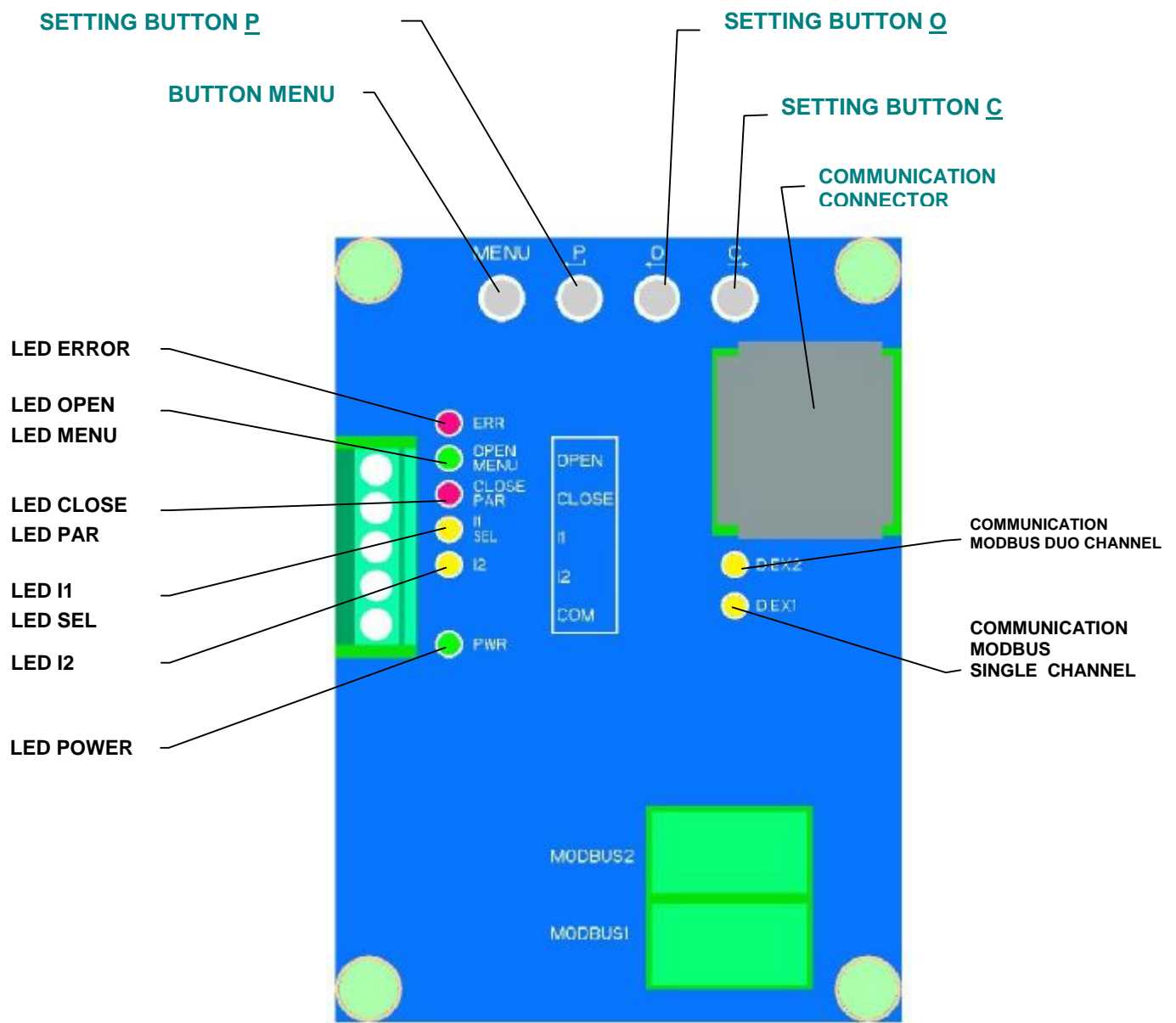

Fig.6a

3.1 EA control set-up options (regulating)

3.1.1 Control setting possibilities for EA's with DMS3 electronic control

2P CONTROL

Setting-up: **2P** control + other functions, in addition to **STOP** on I1 terminal:

The EA moves either to the OPEN or CLOSE direction with **24V DC** voltage supplied to terminals **OPEN** or **CLOSE**. The EA stops if power supply is cut-off or the end position is reached.

2P PULSE CONTROL

Setting-up: **2P** control + **STOP** function on I1:

The EA moves either to the OPEN direction or closes with **24V DC** voltage pulse supplied on connectors **OPEN** or **CLOSE**. The pulse may not be shorter than xx seconds.

The EA stops – shutting off - once the 24V DC voltage is supplied on I1 connector (STOP) or the set end position is reached.

3P CONTROL (REGULATING)

Setting-up: 3P control + other functions, in addition to STOP on I1 and other ones in addition to 2P on I2 input.

The EA moves either to the OPEN or CLOSE direction with **0/4 – 20 mA (0/2 up to 10V) input control signal** supplied on terminals **+IN, -IN**. The EA stops once the required position is reached (corresponding with the input control signal supplied) or the set end position is reached.

Note: The ES fails to stop in case that the STOP function is selected on I1 input with 3P control mode and 24V DC voltage supplied on I1 terminal.

3P/2P switched over to I2

Setting-up: **3P/2P** control switched over to **I2** (**2P** function is automatically selected for **I2** input function in selecting this control option) + other functions in addition to STOP on I1:

The EA moves either to the OPEN or CLOSE direction with **0/4 – 20 mA (0/2-10V) input control signal** supplied on terminals **+IN, -IN**. The EA stops once the required position is reached (corresponding with the input control signal supplied) or the set end position is reached.

The EA stops to respond to **0/4/12 to 20 mA, 4 to 12 mA (0/2-10V) input control signal** and rests in case of **I2 active input** (with 24V DC constantly ON or OFF – as per I2 function set-up to ACTIVE – or supplied on I2 connector). The EA is allowed to move either to the **OPEN** or **CLOSE** direction with **24V DC** voltage supplied to terminals **OPEN** or **CLOSE**. The EA stops if power supply is cut-off or the end position is reached. The EA stops to respond to the input control signal and fixes its position once the supply voltage on I2 is OFF.

3P/2P switched over to I2 (PULSE 2P)

Setting-up: **3P/2P** control switched over to **I2** (**2P** function is automatically selected for **I2** input function in selecting this control option) + other functions in addition to **STOP** on I1:

The EA moves either to the OPEN or CLOSE direction with **input control signal 0/4 – 20 mA (0/2 to 10 V)** supplied on connectors **+IN, -IN**. The EA stops once the required position is reached (corresponding with the input control signal supplied) or the set end position is reached.

The EA stops to respond to **0/4/12 to 20 mA, 4 to 12 mA (0/2-10V) input control signal** and rests in case of **I2 active input** (with 24V DC constantly ON or OFF – as per I2 function set-up to ACTIVE – or supplied on I2 terminal). The EA is allowed to move either to the OPEN or CLOSE direction with **24 V DC** voltage pulse supplied connectors **OPEN** or **CLOSE**. The EA stops once the 24V DC voltage is supplied on I1 terminal (STOP) or the set end position is reached.

The EA stops to respond to the input control signal and fixes its position once the supply voltage on I2 is OFF.

3.1.2 Control setting possibilities for EA's with DMS3 electronic control with Modbus/Profibus protocol

2P CONTROL (two position controller)

Setting: the two position controller is activated by setting the bit 3P=0 in the corresponding Modbus/Profibus register:

The EA moves in the direction of open or closed **when the bits are set as OPEN**, resp. **CLOSE in the corresponding Modbus/Profibus register**.

3P CONTROL (three position controller)

Setting: the three position controller is activated by setting the bit 3P=1 in the corresponding Modbus/Profibus register:

The EA moves in the direction of open or closed **in accordance with the requirements sent through the Modbus/Profibus interface**.

EMERGENCY CONTROL

Note: In cases where the EA is equipped with a local control, it is possible to activate the emergency control only if the local control block is set to remote control. The local control block has higher priority than the **ESD** or **E2P**.

- **ESD (Emergency Shutdown)** – is activated when the function parameter is set as **I1=ESD** and the I1 input is activated or when the function parameter is set as **I2=ESD** and the I2 input is activated. The EA takes up the position which corresponds to the settings of the **response to error parameter after input activation**. The **ESD emergency control has higher priority than the E2P control**.
- **E2P (Emergency 2P)** – is activated when the function parameter is set as **I2=E2P** and the I2 input is activated. The **E2P emergency control has lower priority than the ESD control**. Emergency 2P operates in two modes and uses the following inputs:
 - **Permanent signal** – the EA opens or closes only when a signal is present on the **OPEN, CLOSE inputs**.
 - **Impulse mode** – the EA opens or closes after supplying an impulse to the **OPEN, CLOSE inputs**. The EA is stopped after supplying an impulse to the **I1 input**. This mode is similar to the settings of the function **I1=STOP**.

3.2 Procedure for setting individual parameters and the register of errors and warnings

- is given in the separate attachment 74 1053 02 resp. 74 1076 02 of these operating instructions.

The factory default setting of individual programmes shown in Table 2 and Table 3, as long as otherwise specified by the customer:

Table 2
Factory default settings of individual parameters in version without local control; possibility to set-up by operating the control unite buttons.

For the individual parameters set-up see appendix 74 1053 02

MENU			NAME	FACTORY SETTING-UP	
DMS3	MODBUS	Profibus			
	1		TORQUE	100% of value shown on nameplate for OPEN & CLOSE direction.	
	2		END LIMIT	- C = Position + O = Position - end position switching closed and open from position if valve type is not specified - C = Torque + O = Position - closed in end by thrust position and end position switching open from position for single-seat valves - C = Torque + O = Torque – switching in both end positions by thrust for double-seat valves	
	3		TORQUE BLOCKING	- 2 sec. blocking time - 5% blocking position for OPEN & CLOSE direction	
	4		RELAY READY	- errors (READY COM-NO relay contacts closed in error free conditions)	
	5		RELAY R1...RE5	- position O for relay R1 - position C for relay R2 - from position 95% for relay RE3 - from position 5% for relay RE4 - disabled for RE5 relay	
6	-	-	CPT (output signal)	4 to 20 mA	
7	-	--	REGULATION – (according to specification)	2P	3P
			ANALOG INPUT	-	4 to 20 mA (2 to 10 V)
-	5	-	ADDRESS	2	
-	-	6	ADDRESS 1	2	
			ADDRESS 2	3	
-			BAUDRATE PARITY REDUNDANCY	115200 bit/s EVEN OFF (for single Channel version) COMPONENT (for duo Channel version)	
-	-	7	REDUNDANCY	OFF (for single Channel version) Single (for duo Channel version.)	
	8		DEAD ZONE	-	3 %
	9		FAILURE REACTION	STOP	

Other parameters set-up is possible to change only by using the PC software

TITLE	FACTORY SETTING-UP
DIRECTION OF ROTATION	clockwise.
THERMOSTAT TEMPERATURE	25 °(space heater OFF temperature)
INTERNAL DEAD ZONE	2 % (only for 3P)
Safe position	0 %
FUNCTION I1	ESD
ACTIVE I1	high level

FUNCTION I2	DISABLED
ACTIVE I2	high level
THERMAL FUSE FAILURE	for this type of electric actuators is inoperative
THERMAL FUSE RESET	for this type of electric actuators is inoperative
CYCLE MODE	DISABLED
CYCLE RUNNING TIME	10 s
CYCLE PAUSE	50 s
CYCLE POSITION O1	0 %
CYCLE POSITION O2	100 %
CYCLE POSITION C1	0 %
CYCLE POSITION C2	100 %
O AND C TOLERANCE	1 %
CREATE BACKUP	START
RESTORE FROM BACKUP	START
RESTORE FACTORY SETUP	START
ACTIVE ERRORS	CLEAR
DIRECTION OF ROTATION	clockwise
CONNECT TIME (Modbus)	3s

Table 3				
Factory default settings of individual parameters in version with local control; possibility to set-up by operating the local control buttons. For the individual parameters set-up see appendix 74 1076 02.				
MENU			FACTORY SETTING-UP	
DMS3	MODBUS	Profibus	NAME	
	1		JAZ/LANGUAGE	English (select language on LCD display)
	2		POSITION O	work angle range set as per EA specification
	3		POSITION C	
	4		REG. CALIBR.	START
	5		END LIMIT	<p>- C = Position + O = Position - end position switching closed and open from position if valve type is not specified</p> <p>- C = Torque + O = Position - closed in end by thrust position and end position switching open from position for single-seat valves</p> <p>- C = Torque + O = Torque – switching in both end positions by thrust for double-seat valves</p>
	6		TORQUE O	100% of value shown on nameplate
	7		TORQUE C	100% of value shown on nameplate
	8		BLOCK. TIME	2 s
	9		BLOCK. POS. O	5 %
	10		BLOCK. POS. C	5 %
11	-	-	CPT (output signal)	4 to 20 mA
12	-	-	REGULATION-(according to	2P 3P
13	-	-	ANALOG. INPUT	- 4 to 20 mA (2 to 10 V)
14	16	14	DEAD ZONE	- 3 %
15	17	15	INT. DEAD Z.	- 2 %
16	18	16	FAIL. REACT.	STOP
17	19	17	SAFE POSIT.	0 %
18	20	18	FUNCTION I1	ESD
19	21	19	ACTIVE I1	high level
20	22	20	FUNCTION I2	DISABLED
21	23	21	ACTIVE I2	high level
22	24	22	THERMO. FAIL. (THERMAL FUSE	for this type of electric actuators is inoperative
23	25	23	THERMO. RESET (THERMAL FUSE	for this type of electric actuators is inoperative
24	26	24	RELAY READY	errors
25	27	25	RELAY 1	Position O (POSITION OPEN)
26	28	26	RELAY 1 POS.	0 %
27	29	27	RELAY 2	Position C (POSITION CLOSE)
28	30	28	RELAY 2 POS.	0 %
29	31	29	RELAY 3	FROM POSITION
30	32	30	RELAY 3 POS.	95 %
		31	RELAY 4	TO POSITION
		32	RELAY 4 POS.	5 %
33	35	33	RELAY 5	DISABLED (OFF)
34	36	34	RELAY 5 POS.	0 %
35	37	35	CYCLE MODE	DISABLED
36	38	36	CYCLE RUN. T.	10 s
37	39	37	CYCLE PAUSE	50 s
38	40	38	OC TOLERANCE	1 %
39	41	39	INFORMATION	TORQUE

40	42	40	RESTORE BACK.	START
41	43	41	CREATE BACK.	START
42	44	42	RESTORE FACT.	START
43	45	43	ACTIVE ERR:	CLEAR
-	-	44	DIRECTION OF ROTATION	clockwise
-	11	-	ADDRESS	2
-	12	-	BAUDRATE	115200bit/s
-	13	-	PARITY	EVEN
-	14	-	REDUNDANCY	OFF (for single Channel version) COMPONENT (for duo Channel version)
-	15	-	CONNECT TIME	3s
-	-	11	ADDRESS 1	2
-	-	12	ADDRESS 2	3
-	-	13	REDUNDANCY	OFF
Other parameters set-up is possible to change only by using the PC software				
NAME		FACTORY SETTING-UP		
DIRECTION OF ROTATION		clockwise		
THERMOSTAT TEMPERATURE		25 °(space heater OFF temperature)		
CYCLE POSITION O1		0 %		
CYCLE POSITION O2		100 %		
CYCLE POSITION C1		0 %		
CYCLE POSITION C2		100 %		
LCD CONTRAST		0		

Warning 1: When the input control signal is set to the value 0 , 20 mA (0 to 10 V), or 20 , 0 mA (10 to 0 V) and the input control signal fails, then the EA keeps the position as with a 0 mA (0 V) input signal (EA doesn't recognise between input signal fail and 0 mA (0 V) input signal)- not valid for EA EA´s with DMS3 electronic control with Modbus/Profibus protocol.

Warning 2: Auto-calibration process doesn't run if triggered in time when the EA is in error state, e.g. EA is overloaded (EA is switched -off from torque). In such case is necessary to resolve issue, e.g. the EA must be moved in a position in which is not switch-off from torque and to start the auto-calibration again.

Warning 3: Calibration process must be performed at any change of the operating angle value of more than 10%.

Warning 4: Operate adjusting button **P** on the control to activate the calibration process or start it from **MENU 4** in the version with local control (use the buttons on local control) or from the programme once the EA is connected to the PC. All calibration start methods have been equal.

Warning 5: In case that EA with supply voltage 3x400V AC after calibration start shows the error „rotation direction“ (error No. 7), it is necessary to stop EA by switching-off the supply voltage and change the phases sequence on the terminals 2 and 3 (change mutually phases wires) and after switching-on the supply voltage run in the calibration again.

Rotation direction definition of the electric actuator's output element

The output rod of the actuator while rotating in the direction "Close" protrudes from the actuator. It means that the direction of rotation of the actuator is set as clockwise.

In case the direction of rotation shall be changed the parameter „Direction of rotation of the actuator“ must be adjusted as anticlockwise. This parameter can be adjusted through the PC only by use of the EHL Explorer SW. The PC must be connected to the actuator via communication cable and the window "Parameters" used for direction adjustment, in some cases by local control buttons.

3.3 Putting an EA into operation when the EA is set up and connected with the armature already in the production plant (starting the calibration)

If EA is delivered from manufacturing plant joined with valve, or with control device, **calibration** must be performed to ensure correct operation, under actual pipeline conditions.

The procedure is as follows:

- fit the given assembly into the specified technology complex

- connect the EA on the supply voltage electrically according to the wiring diagram and chapter Electric connection and checking of function.
- introduce the EA into an mid-position (see Note 2 presented above)
- switch on the supply voltage
- **start the EA calibration** by pressing the **P** button on the control unit **for 2 seconds as minimum** until LED ERROR (red), LED MENU (green) and LED PAR (red) light up – see also the procedure in the separate attachment **No.74 1053 02**
- release the **P setting button**
- after releasing the **P** button the calibration procedure starts – inertia measuring
- after the calibration procedure is finished, the EA is prepared for its operation and starts to response to control inputs
- if changes to some parameters would be necessary, proceed please according to the instructions given in the separate attachment **No. 74 1053 02.**

3.4 Putting an EA into operation when the stroke and parameter setting done by the producer suit to your needs

When an EA is delivered from the producer without armature and the setting of stroke (stroke end positions) and other parameters done by the producer suit Your needs, please proceed as follows:

- connect the EA with the armature to be controlled (**according to chapter 2**) and fit this assembly into the specified technology complex
- connect the EA electrically according to the wiring diagram and chapter Electrical connection and checking of function
- introduce the EA into an mid- position (see Note 2 presented above)
- switch on the supply voltage
- start the EA calibration by pressing the **P** button on the control unit **for 2 seconds as minimum** until LED ERROR (red), LED MENU (green) and LED PAR (red) light up – see also the procedure in the separate attachment No. 74 1053 02
- release the **P** setting button
- after releasing the **P** button the calibration procedure starts
- after the calibration procedure is finished, the EA is prepared for its operation and starts to response to control inputs
- if changes to some parameters would be necessary, proceed please according to the instructions given in the separate attachment No. 74 1053 02.

3.5 Putting an EA into operation when it is necessary to do a change to the stroke (setting new end positions), and the other parameter setting done by the producer suits to your needs

When an EA is delivered from the producer without armature, and the setting of other parameters done by the producer suit to your needs, and it is necessary to do a change to the EA stroke, proceed as follows:

- connect the EA with the armature to be controlled (according to chapter 2) and fit this assembly into the specified technology complex,
- connect the EA electrically according to the wiring diagram and chapter Electrical connection... ,turn on the power supply, without connection of the control signals fed into EA (The EA will report an error i.e. alarm No. 2 or No. 27 (missing input control signal - or Modbus activity),
- set the EA (using manual control*) to end position closed and push button C for at least 2s, until LED ERROR (red), LED MENU (green) and LED PAR (red) come on – the closed end position is thus recorded in memory – see description in separate annex No. 74 1053 02,
- release the C setting button,
- set the EA (using manual control*) to end position opened and push button O for at least 2s, until LED ERROR (red), LED MENU (green) and LED PAR (red) come on – the opened end position is thus recorded in memory – see description in separate annex No. 74 1053 02,
- release the O setting button,
- introduce the EA into an intermediate position (see Note 2 presented above),

- by pressing the P pushbutton on the control unit for at least 2s activate the EA calibration until LED ERROR (red), LED MENU (green) and LED PAR (red) come on – see also description of the procedure in separate annex No. 74 1053 02,
- release the adjustment pushbutton P - upon release of the P pushbutton, the calibration process is started,
- turn on the control signals, EA is ready for operation and responds to control inputs,
- if any of the parameters need to be changed, proceed according to the instructions in separate annex No. 74 1053 02.

* This applies to the standard setting of menu 9 (in the menu on the control unit) FAILURE REACTION: STOP!

3.6 Setting other parameters

If changes to some parameters would be necessary, proceed please according to the instructions given in the separate attachment **No 74 1053 02**.

3.7 Error messages from the control unit

The EA electronics makes possible to identify some failures of EA. The failure is signalled by flickering LED ERROR (red) on the control unit (**Fig.6**). An error has also been indicated on the LED display. An error is indicated on the LCD display in the local control EA version.

The list of errors and warnings compiled by the producer is presented in **table 4** (chapter 4.3).

The list of errors and warnings and the way for identifying a given error as well are presented in the separate attachment No **74 1053 02**.

A field serviceman is only entitled to change the errors and warnings set using the programme once the EA is connected to the PC.

4. Service and Maintenance

4.1 Service



1. In general it is provided that service of the EA is performed by a qualified worker in accordance with requirement given in Chapter 1!
2. After putting the EA into operation it is needed to verify whether during manipulation any scratch on surface occurred, it is to be removed to prevent actuator against corrosion!

The EA requires just negligible service. Proper putting into operation is a recondition of reliable operation.

The service of the EA leads from the operation conditions and usually resides in information processing for further arranging of required functions. The EA can either undergo electric remote control or manual control from the installation site. Operate the hand handle for manual control.

The stuff has to perform prescribed maintenance to prevent the EA during operation against impacts of environment, which exceed the frame of allowed influences.

At a power outage or voltage breaking off, an electric actuator will stop in a position, in which it had been before the power outage occurred. In case of need it is possible to preset the electric actuator with manual operation.

Manual control:

If needed (during adjusting, function checking, failure etc.) the stuff can change setting of the controlled body using the hand wheel. While rotating the hand wheel clockwise the output part moves in the direction "Z - closed".

Electric local control: - additional equipment (Fig.7)

If necessary in the case of accession, function check and so on, it is possible to preset EA or change some parameters by local electric control with secured power feeding.

It is possible to control after removing of the padlock (1). Control mode selection is changed by sequential pressing of the button (2) **REMOTE-OFF-LOCAL** to "**Remote**" "**Shut off**", "**Local**", "**Shut off**", which is displayed on 2 rows LCD (6). Signalling motion and failure of the EA is also indicated by LEDs diode (7).

Mode "**Shut off**" – it is possible to change some parameters in this mode in particular menus.

Mode "**Local**" – it is possible to control EA by the local buttons in this mode - (3) **OPEN**, (5) **STOP**, (4) **CLOSE**.

Mode "**REMOTE**" – it is possible to control EA by the commands from superior remote system

Proceeding in setup of particular parameters in the mode "**SHUT OFF**" is described in the independent amendment No. 74 1076 02, which is delivered together with EA equipped by local electric control.

When you finish the work in the "**REMOTE**" mode put the padlock on the button (2) again. This measure would be received because of potential unauthorized person's intervention.

Note: Modes of Local or Remote control is conditioned by program choices of inputs I1 and I2. In the case that inputs I1 or I2 are programmed for "Local releasing", it is only possible to control the EA by local control with active input I1 or I2.

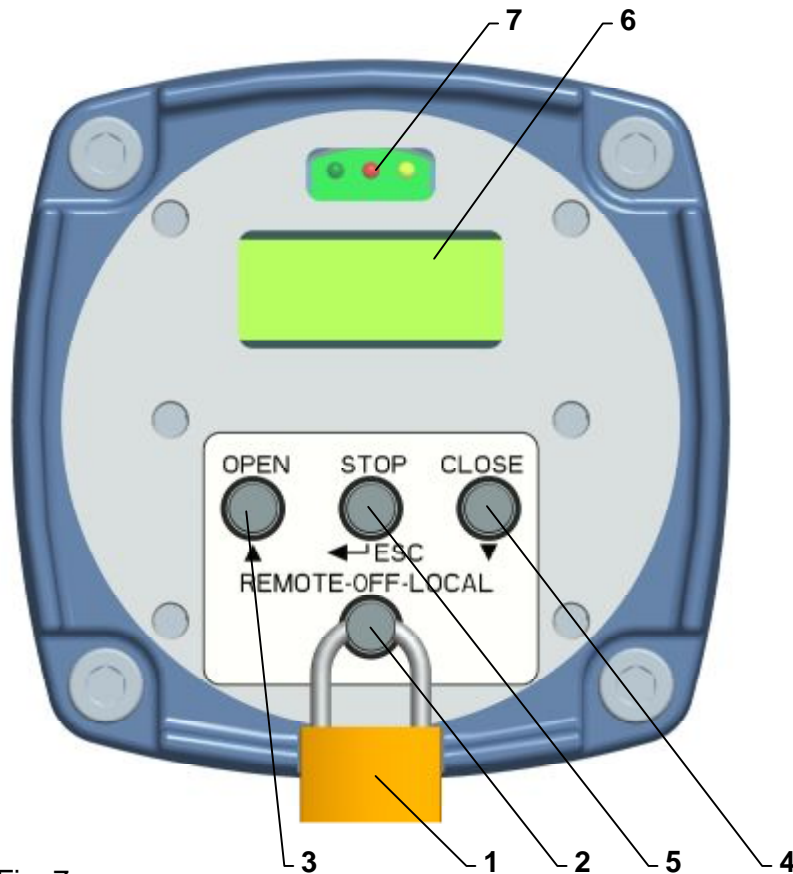

Fig. 7

4.2 Maintenance - extent and periodicity

All screws and nuts affecting tightness and protection (IP) must be tightened during the inspection and maintenance. Similarly, once a year should be checked and if necessary tightened mounting screws of the terminal wires and assuring of the slip-on joints with wires.

The interval between two preventive inspections is four years.

In case of damage or after 6 years of the actuator's operation the replacement of cover seals and oil filling seals must be done.

The grease in the supplied actuators is designed for the lifetime of the product. It is not necessary to change the grease during the operation of the actuator.

Lubrication:

- gear part - in versions for climate with temperatures -25°C till $+55^{\circ}\text{C}$ – grease HF 401/0 (GLEIT- μ) resp. GLEITMO 585 K
- in versions for climate with temperatures -50°C till $+40^{\circ}\text{C}$ grease ISOFLEX TOPAS AK 50
- in versions for climate with temperatures -60°C till $+55^{\circ}\text{C}$ grease DISCOR R-EP 000.
- linear adapter – grease GLEIT- μ - HP 520M (to -25°C) resp. HP 520S (to -40°C).



Lubrication of the valve stem is independent on maintenance of the EA!

After every potential flooding of the product check, whether there is no water inside. After eventual water penetration, dry the product before repeated putting into operation and replace damaged sealings, resp. other parts of EA. identically check also tightness of cable bushings and replace them, if they are damaged.

- Every six months it is recommended to perform one check move in frame of adjusted operation stroke to verify reliability of functioning with setting back to the original position.
- If the audit rules do not determine else the inspection of EA is performed ones a year and tightening of all connecting and grounded screws have to be checked to avoid overheating.

- After 6 months from putting of EA into operation and once a year it is recommended to check tightening of fixing screws between the EA and the valve. (Tighten the screws with the cross system.)
 - While connecting and disconnecting of the EA check the tightness of cable glands – those with damaged sealings should be replaced by new ones of the approved type!
 - Keep the EA clean and take care about removing impurities and dust. The cleaning has to be performed regularly according to the operation possibilities and requirements.



4.3 Troubleshooting

At failure of power supply the EA stops in the position where it was before the failure. If needed the EA can be set only with the manual control (the hand wheel). After restoration of power the EA is prepared for operation.

In case of failure of any element of the EA it can be changed by a new one. Entrust the change to a service centre.

In case of an EA failure, which cannot be eliminated directly in operation, follow instructions for under-guaranty and after-guaranty service.

Note: If the EA requires dismantling follow the chapter "Dismantling".

The EA electronics makes possible to identify some failures of the electric actuator. The control unit blinking LED ERROR indicates the failure (**Fig. 6**) or the error is displayed on the LED (**Fig. 1**), or the LCD display (**Fig. 7**). The list of errors and warnings and the way for identifying a given error as well are presented in the separate attachment No 74 1053 02.

The list of errors and warnings compiled by the producer is presented in **table 4**. A change to the list of errors and warnings in the EA is only possible within a service intervention, through the program installed in a PC.

Table 4 setting error flags and warning flags as at the delivery		
PARAMETER	ERROR	WARNING
ESD		X
Analog Input – not valid for Modbus/Profibus protocol		X
Modbus/Profibus activity – only for Modbus/Profibus protocol		X
Wrong command	X	
Torque		X
Torque check		X
Torque calibration	X	
Regulator calibration		X
Stroke (turns sum)	X	
Wrong position	X	
Spin	X	
Spin direction	X	
RAM	X	
ROM	X	
EEPROM		X
Bus	X	
I2C	X	
Reset		X
Voltage +5V		X
Parameters	X	
Set mode		X
Relay		X
Temperature <		X
Temperature >		X
Phase	X	
Power frequency	X	
Thermal fuse	X	
Manual control	X	
Position module	X	
Position module type	X	
Position sensor 1	X	
Position sensor 2	X	
Position sensor 3	X	
Position sensor 4	X	
Torque module	X	
Torque module type	X	
Torque sensor	X	
LED module	X	
LED module type	X	
LCD module	X	
LCD module type	X	
Power Supply/Relay module	X	
Power Supply/Relay module type	X	
E2P	X	
Profibus Channel 1- only for version with Profibus	X	
Profibus Channel 2- only for version with Profibus	X	

Notes: **X** – the error or warning flag is activated.

With the **error flag**, the EA takes the position defined for the FAILURE REACTION function eventually stops (depending on the kind of the error), and it will not operate until the error is removed.

With the **warning flag**, the EA continues in operation.

The user is advised on error or warning through the READY relay (according to the relay setting), by LED ERROR blinking on Control unit, by ERROR message on LED or LCD display, eventually through the program after connecting the EA with a PC

Note 1: In some cases having the error removed the electric actuator must be restarted by switching-off the voltage supply to the electric actuator for about 3 sec.

If some EA element would fail it can be replaced with a new one. The **producer's service centre** only is allowed for such replacement.

If your EA would fail, proceed please according to the instructions for the under guarantee and after-guarantee

For repairing eventually the electronics use the fuse – see Fig.2 (F3) for example SCHURTER MSF 250, or sub miniature SIBA 164550 xxx (see chapter 1.9.2), which is located on source board.



Taking the EA to pieces for repair purposes is allowed only by professionally qualified persons trained in the production plant or by a contracted service centre!

5. Accessories and spare parts

5.1 Accessories

The EA is delivered with the **handwheel and cable glands**.

5.2 Spare part list

Table 5 Spare part	Order Nr.	Position	Figure
Electric motor; 15W/39 VA; 230/220 V AC; 50 Hz	63 592 314	1	1
Electric motor; 15W/39 VA; 24 V AC; 50 Hz	63 592 356	1	1
Electric motor; 18W/48 VA; 24 V AC; 60 Hz	63 592 061	1	1
Electric motor; 18W/48 VA; 240 V AC; 60 Hz	63 592 059	1	1
Electric motor; 18W/48 VA; 120 V AC; 60 Hz	63 592 060	1	1
Electric motor; 20W/75 VA; 230/220 V AC; 50 Hz	63 592 118	1	1A
Electric motor; 25W/70 VA; 120 V AC; 60 Hz	63 592 058	1	1A
Electric motor; 60W/120 VA; 230/220 V AC; 50 Hz	63 592 322	1	1A
Electric motor; 70W/125 VA; 240 V AC; 60 Hz	63 592 055	1	1A
Electric motor; 70W/125 VA; 120 V AC; 60 Hz	63 592 056	1	1A
DMS3 Z2 24A source board of electronic for 24 V AC	64 051 072	3	1,1A
DMS3 ZS switch – mode power supply for 230 V AC and 115 V AC	64 051 103	3	1, 1A
Position scanning unit DMS3 SM	64 051 088	4	1, 1A
Torque scanning unit DMS3 ST	64 051 080	6	1, 1A
Control unit of the electronics DMS3 J1 (0/4/12 to 20 mA, 4 to 12 mA resp. 20 to 0/4/12 mA, 12 to 4 mA, or 0/2 to 10 V, resp. 10 to 0/2 V)	64 051 075	2	1, 1A
Control unit of the electronics DMS3 J3 (0/2 - 10 V)	64 051 061	2	1, 1A
Control unit of the electronics DMS3 J2 (without input and output)	64 051 060	2	1, 1A
DMS3 M1 - Control unit MODBUS Single Channel	64 051 051	2	1, 1A
DMS3 M2 - Control unit MODBUS Duo Channel	64 051 052	2	1, 1A
DMS3 P1 - Control unit PROFIBUS Single Channel	64 051 037	2	1, 1A
DMS3 P2 - Control unit PROFIBUS Duo Channel	64 051 038	2	1, 1A
DMS3 L2 LED display	64 051 081	7	1, 1A
DMS3 LCD display	64 051 082	6	7
DMS3 H3.4 local control sensor	64 051 084	-	7
DMS3 RE3 Module of additional relays	64 051 065	8	1
DMS3 RE6 Module of additional relays	64 051 066	8	1

6. Enclosures

6.1 Wiring diagrams ES STR 1PA and STR 2PA for single phase supply

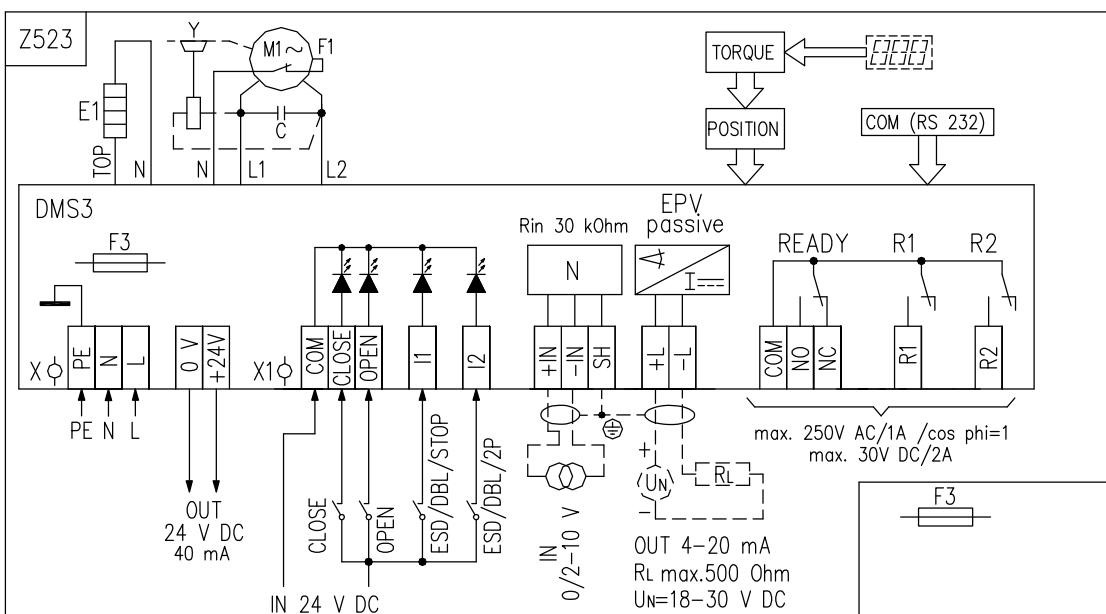
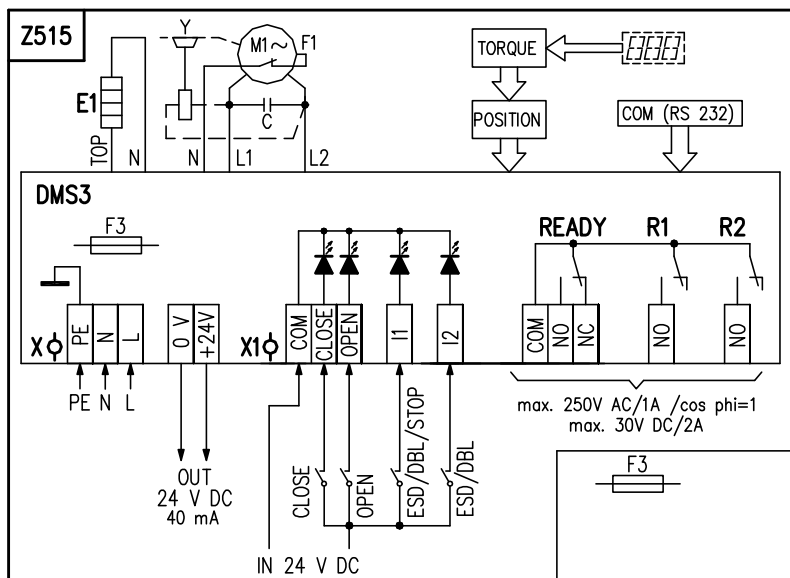
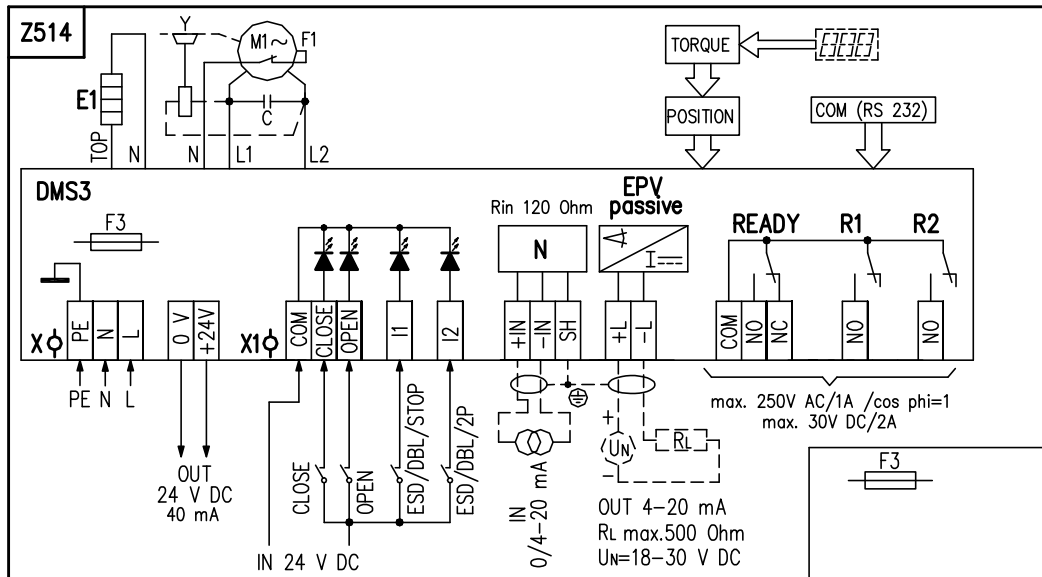

6.2 Wiring diagrams ES STR 1PA for three phase supply

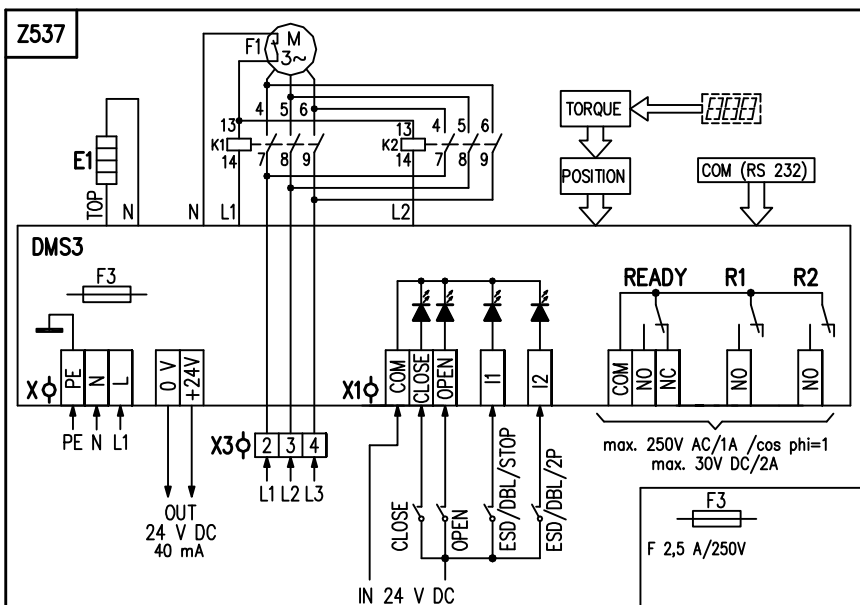
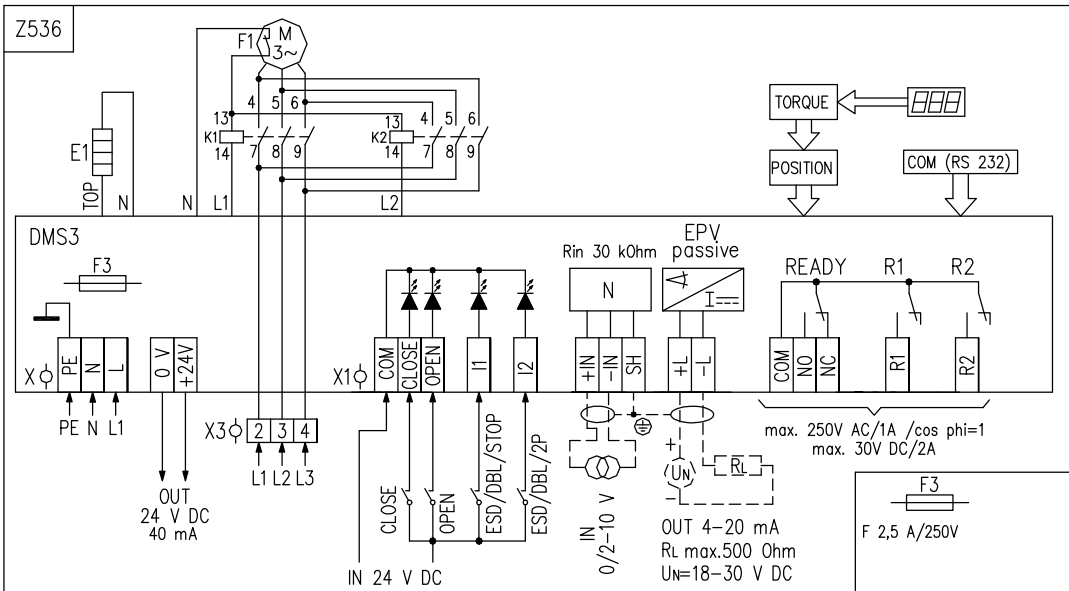
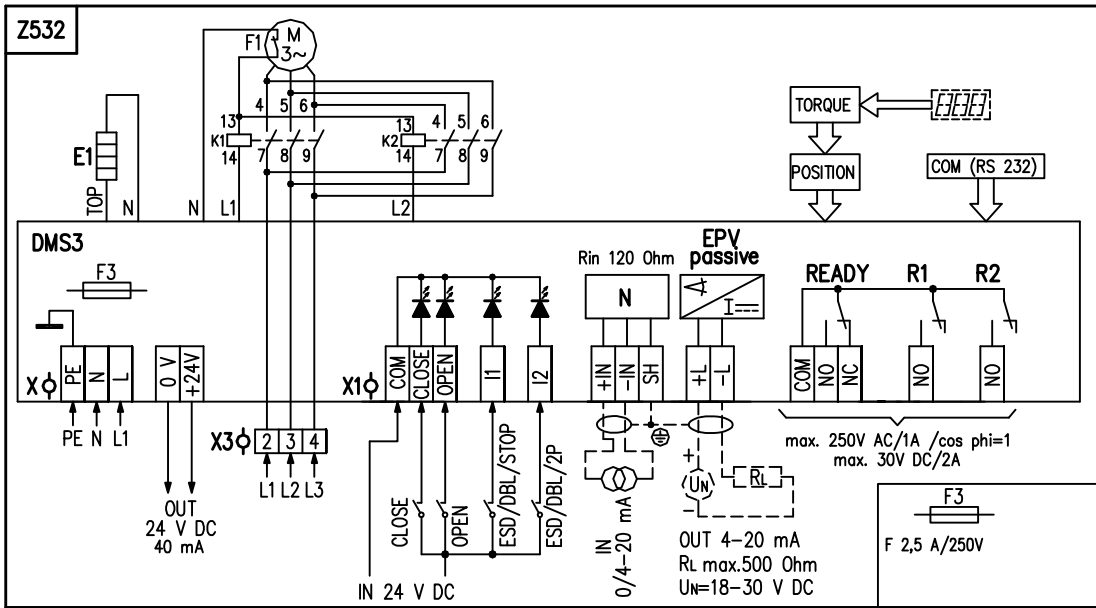

6.3 Wiring diagrams ES STR 2PA for three phase supply

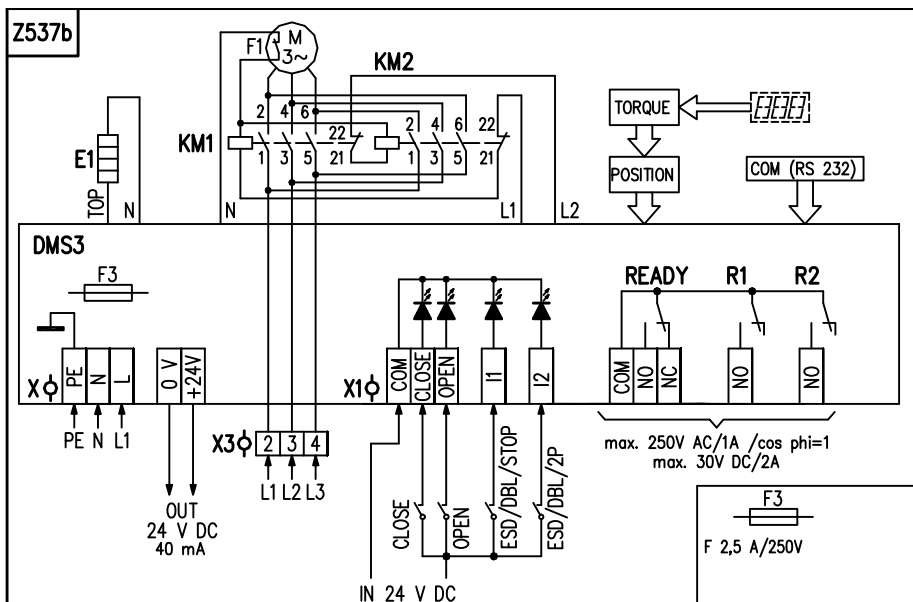
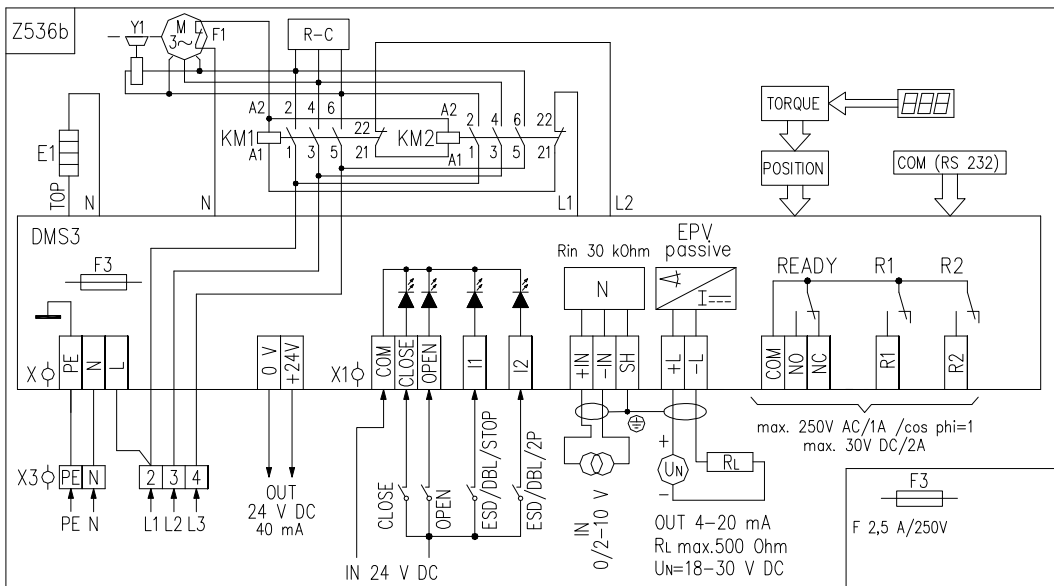
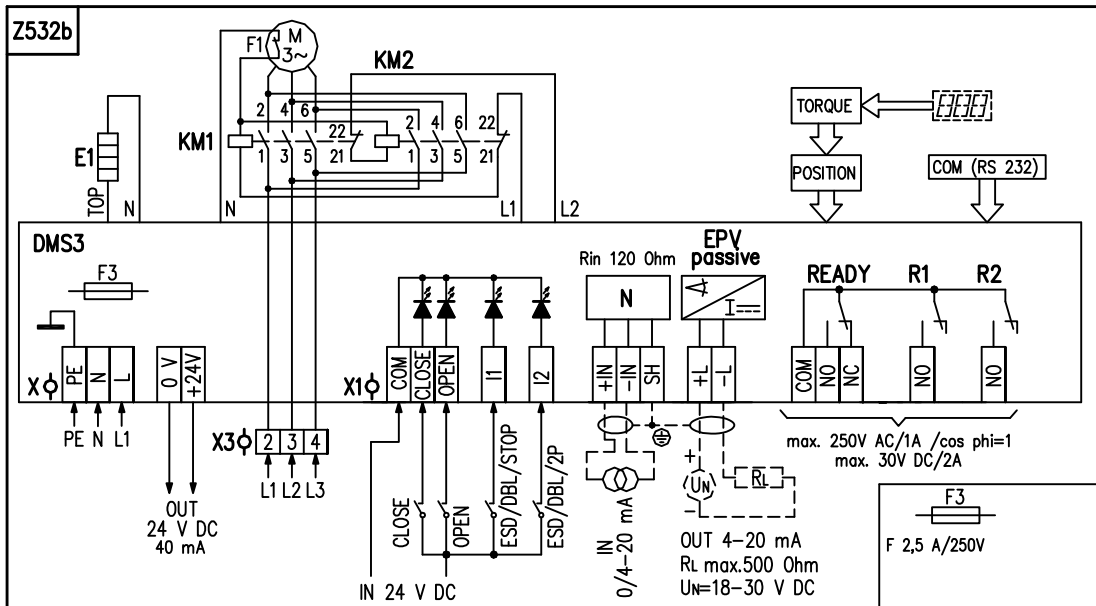

6.4 Wiring diagrams ES STR PA for three phase supply without reverse unit

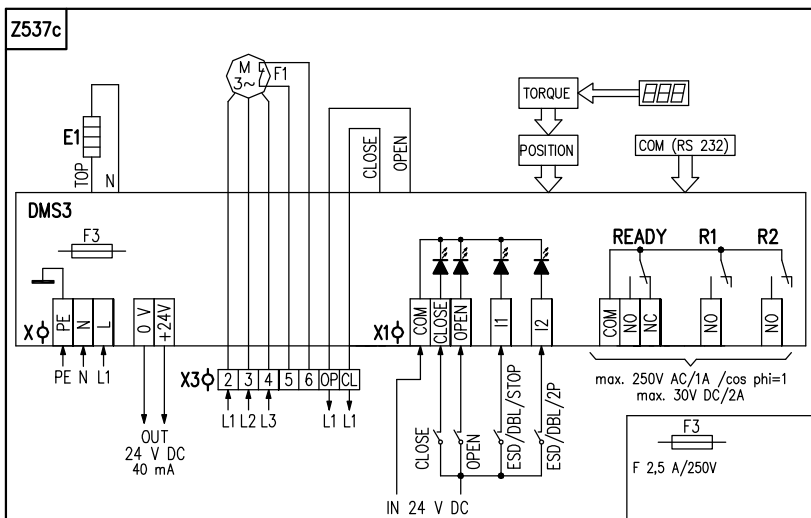
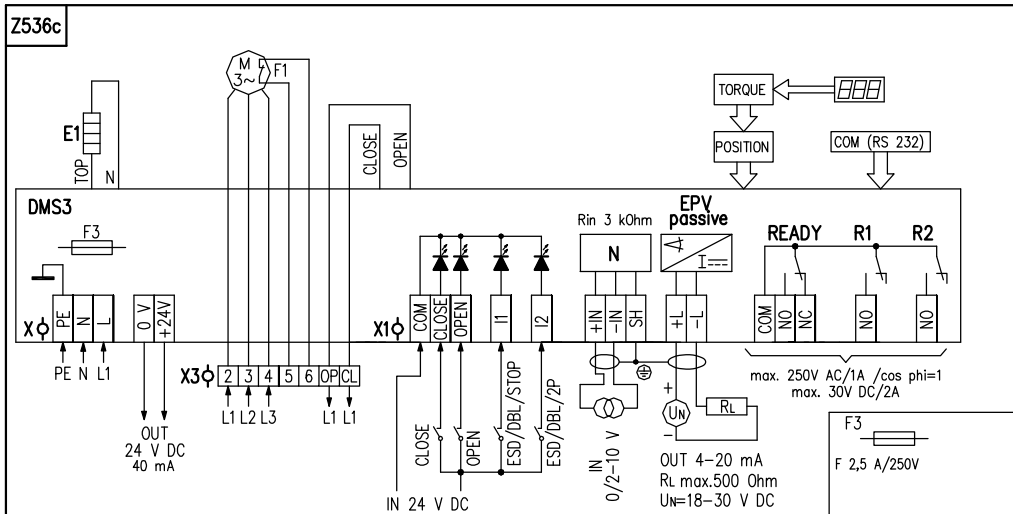
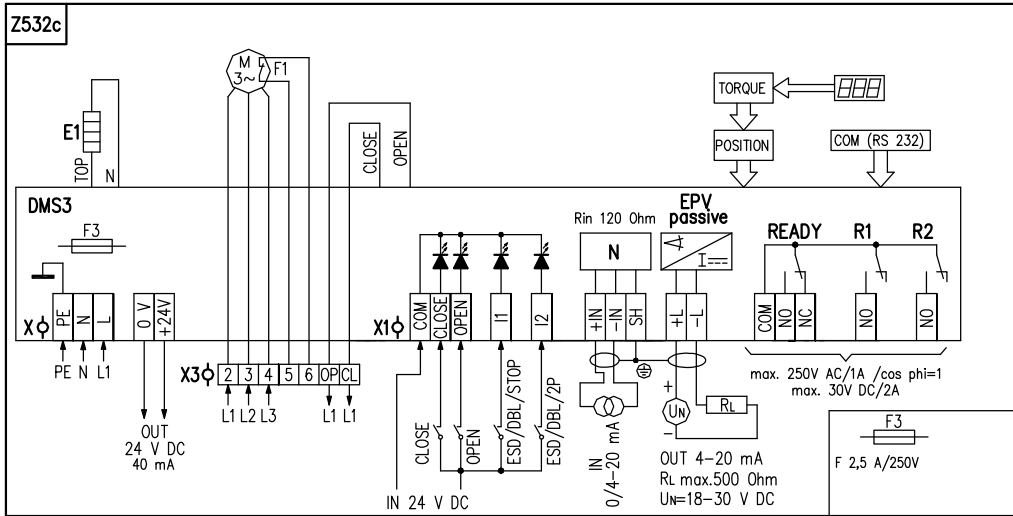

6.5 Wiring diagrams ES STR 2PA – for three phase supply with-contactless switching

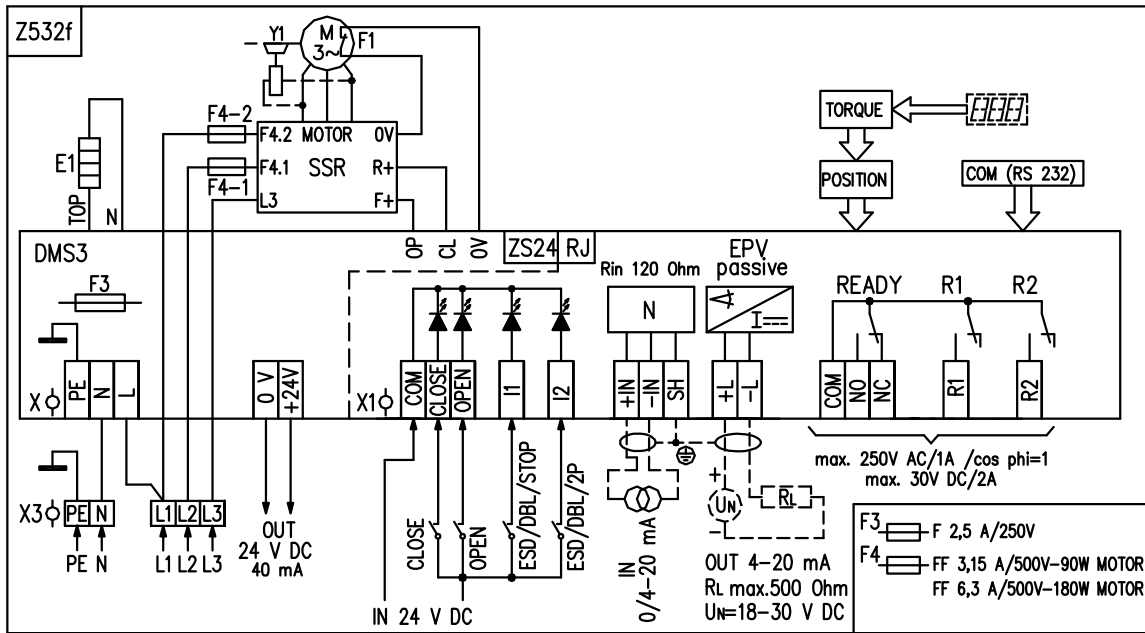

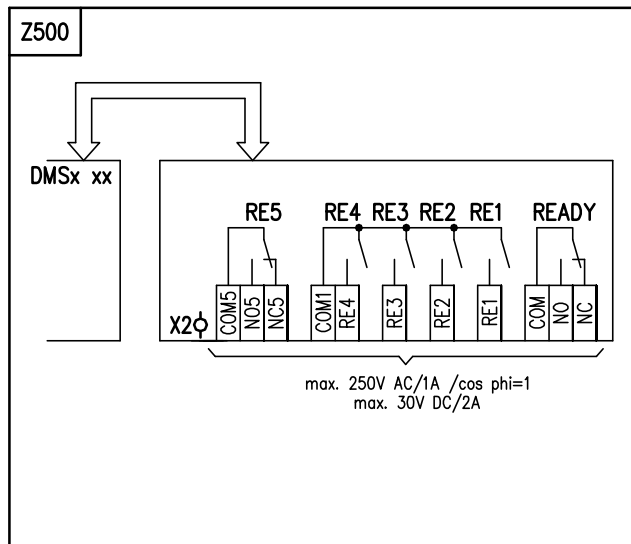
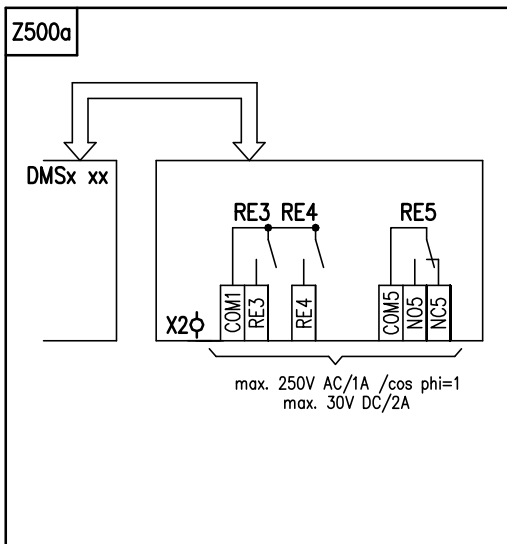
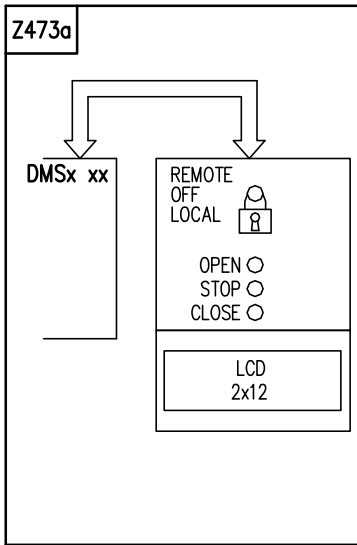

6.7 Wiring diagrams EA STR 1PA with interface Modbus/Profibus for three phase supply

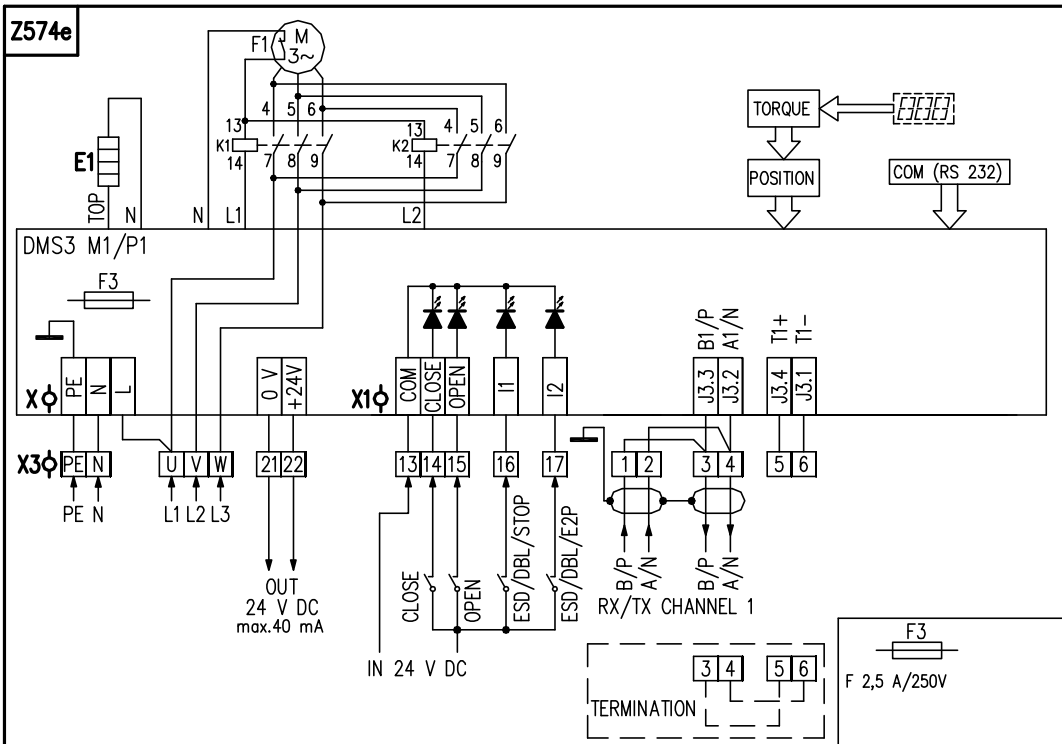
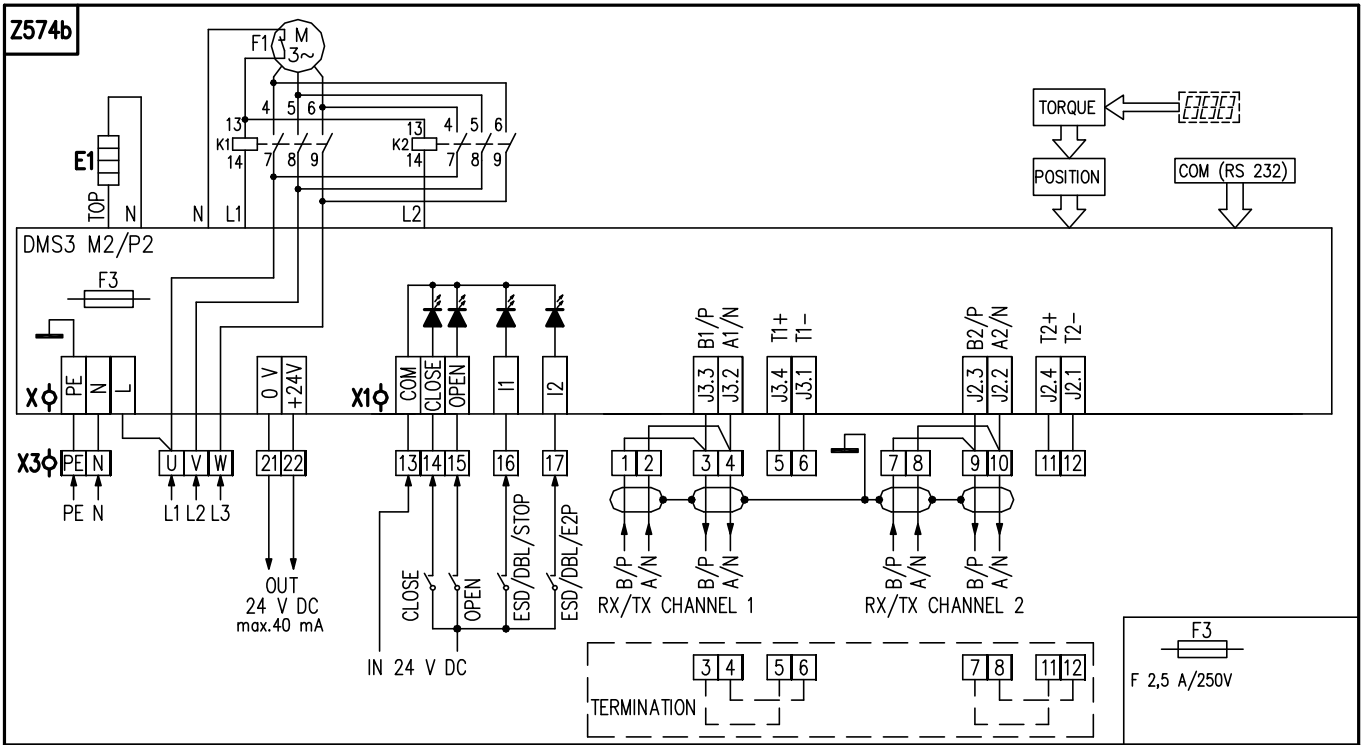

6.8 Wiring diagrams EA STR 1PA with interface Modbus/Profibus for three phase supply

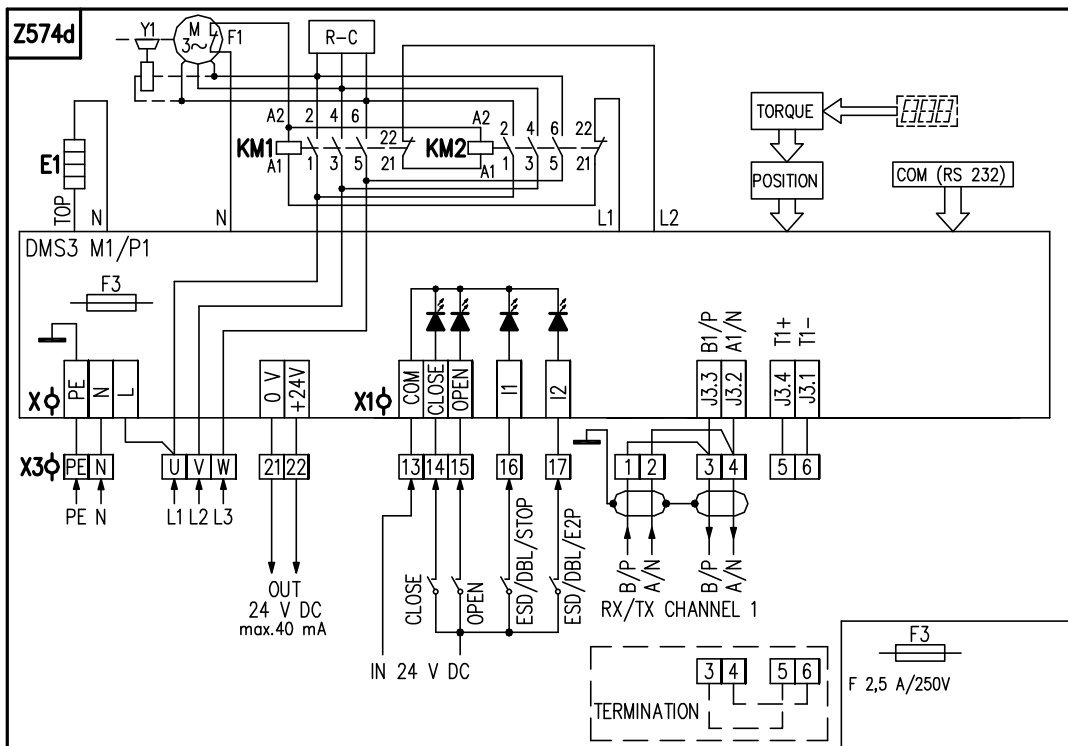
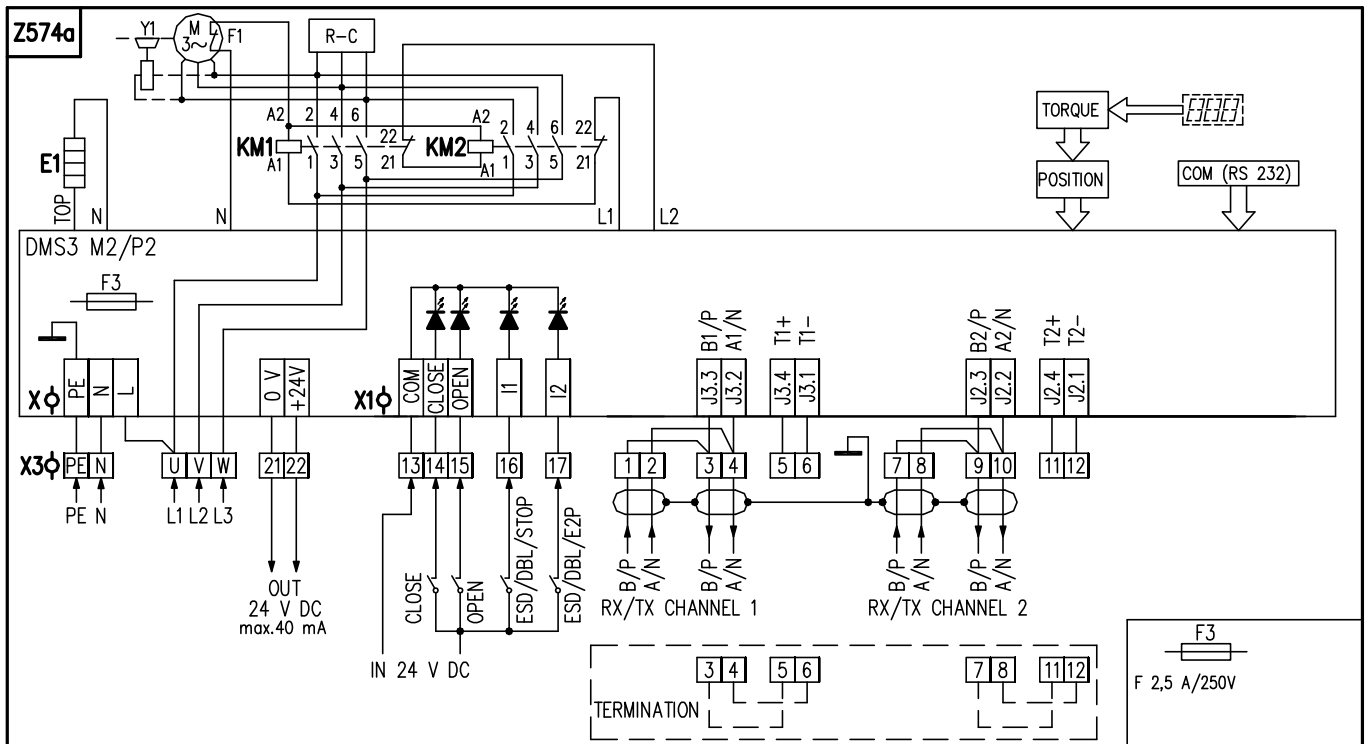

Wiring diagrams EA STR 2PA with interface Modbus/Profibus for three phase supply with contactless switching

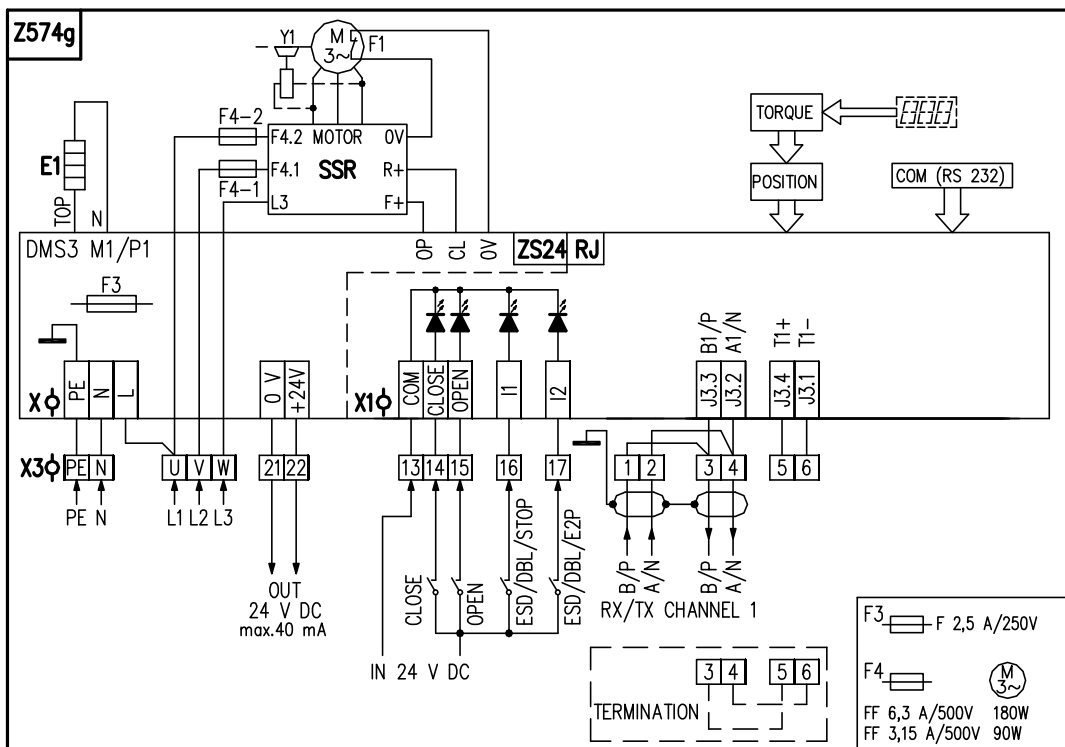
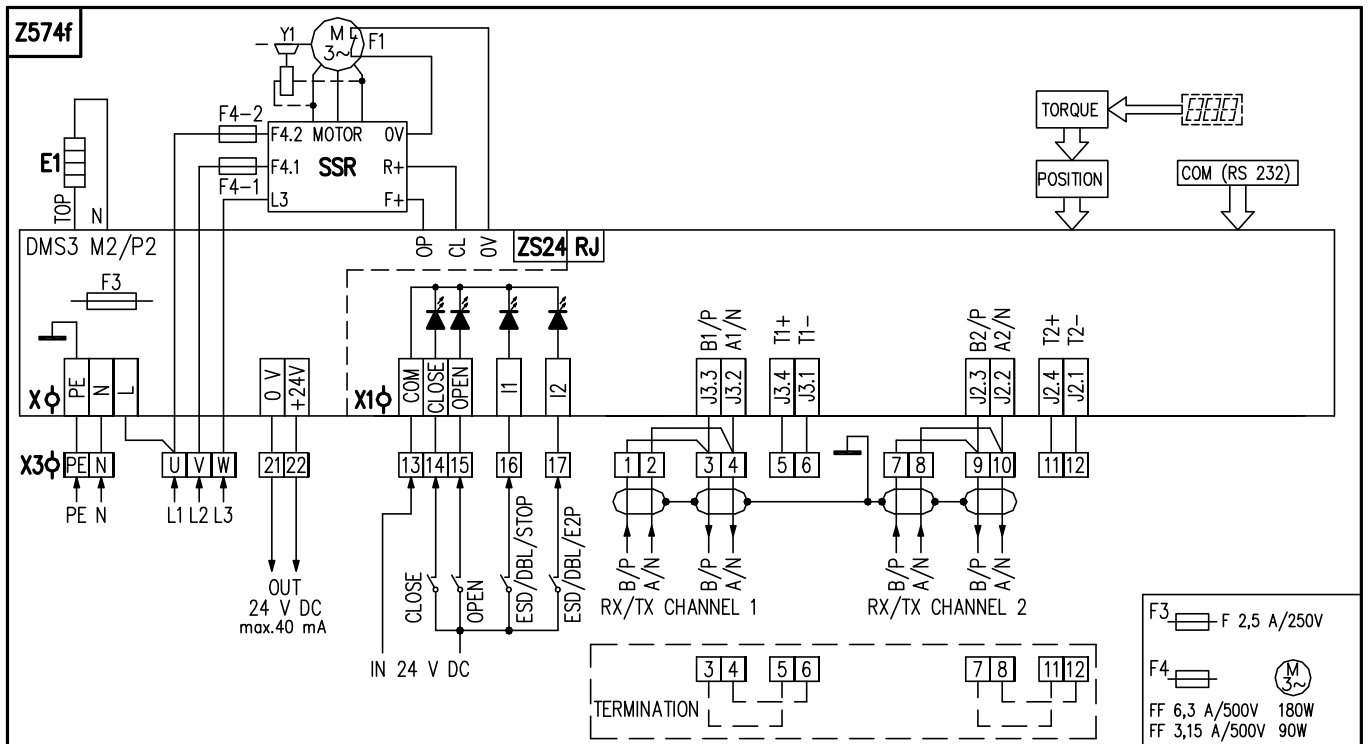

6.9 Wiring diagrams ES STR PA – for three phase supply with-contactless switching

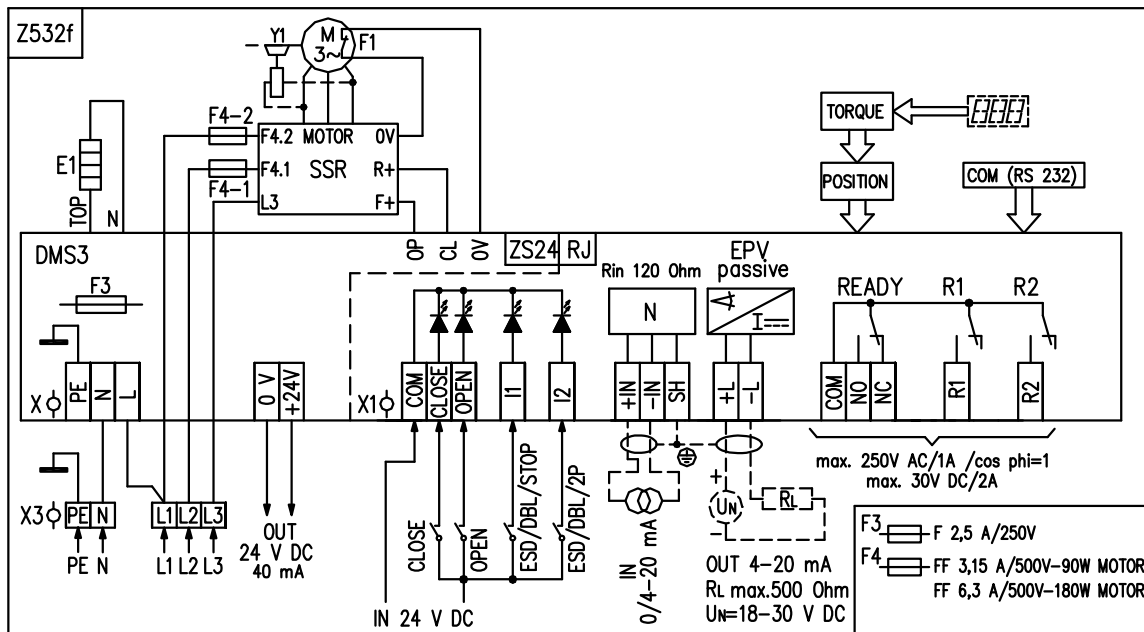

Legend:

Z473a	wiring diagram of electric local control
Z500	wiring diagram module with 6 additional relays
Z500a	wiring diagram module with 3 additional relays
Z500c	wiring diagram of relay RE5
Z514	wiring diagram of EA STR 1PA and STR 2PA with 1-phase electric motor for the ON/OFF control or for analogue input 0/4/12 to 20 mA, 4 up to 12 mA and output signal 4 - 20 mA
Z515	wiring diagram of EA STR 1PA and STR 2PA with 1-phase electric motor for the ON/OFF control
Z523	wiring diagram of EA STR 1PA and STR 2PA with 1-phase electric motor for the ON/OFF control or for analogue input 0/2 - 10 V and output signal 4 - 20 mA
Z532	wiring diagram of EA STR 1PA with 3-phase electric motor for the ON/OFF control or for analogue input 0/4/12 to 20 mA, 4 to 12 mA and output signal 4 - 20 mA
Z536	wiring diagram of EA STR 1PA with 3-phase electric motor for the ON/OFF control or for analogue input 0/2 - 10 V and output signal 4 - 20 mA
Z537	wiring diagram of EA STR 1PA with 3-phase electric motor for the ON/OFF control
Z532b	wiring diagram of EA STR 2PA with 3-phase electric motor with contactors for the ON/OFF control or for analogue input 0/4/12 to 20 mA, 4 to 12 mA and output signal 4 - 20 mA
Z532c	wiring diagram of EA STR PA with 3-phase electric motor without reverse unit for the ON/OFF control or for analogue input 0/4/12 to 20 mA, 4 to 12 mA and output signal 4 - 20 mA
Z532f	wiring diagram of EA STR 2PA with 3-phase electric motor with contactless switching for the ON/OFF control or for analogue input 0/4/12 to 20 mA, 4 to 12 mA and output signal 4 - 20 mA
Z536b	wiring diagram of EA STR 2PA with 3-phase electric motor with contactors for the ON/OFF control or for analogue input 0/2 - 10 V and output signal 4 - 20 mA
Z536c	wiring diagram of STR PA with 3-phase electric motor without reverse unit for the ON/OFF control or for analogue input 0/2 - 10 V and output signal 4 - 20 mA
Z537b	wiring diagram of EA STR 2PA with 3-phase electric motor with contactors for the ON/OFF control
Z537c	wiring diagram of EA STR PA with 3-phase electric motor without reverse unit for the ON/OFF control
Z574	wiring diagram of EA ES STR PA with interface Modbus/Profibus duo Channel – for single phase electric motor
Z574a	wiring diagram of EA ES STR 2PA with interface Modbus/Profibus duo Channel – for three phase electric motor
Z574b	wiring diagram of EA ES STR 1PA with interface Modbus/Profibus duo Channel – for three phase electric motor
Z574c	wiring diagram of EA ES STR PA with interface Modbus/Profibus single Channel – for single phase electric motor
Z574d	wiring diagram of EA ES STR 2PA with interface Modbus/Profibus single Channel – for three phase electric motor with with contactors
Z574e	wiring diagram of EA ES STR 1PA with interface Modbus/Profibus single Channel – for three phase electric motor
Z574f	wiring diagram of EA ES STR 2PA with interface Modbus/Profibus duo Channel – for three phase electric motor
Z574g	wiring diagram of EA ES STR 2PA with interface Modbus/Profibus single Channel – for three phase electric motor with contactless switching

C	capacitor	READY	READY relay (free-programmable)
COM (RS232)	possibility for connecting the control unit to and PC	R1 to RE5	free-programmable relays
EPV passive	electronic position transmitter is passive with output current signal	TORQUE	thrust scanning
E1	space heater	DMS3	electronic module
F1	motor's thermal protection	DMS3 M1/P1	electronic module with Single channel interface Modbus/Profibus
F3	fuse of voltage supply source	DMS3 M2/P2	electronic module with Duo channel interface Modbus/Profibus
K1, K2	coil of relay	X	voltage supply source terminal board with screw terminals
KM1, KM2	coil of contactor	X1	terminal board with screw terminals on the control unit
M	single phase electric motor	X2	terminal board with screw terminals on the additional relays board
N	controller	X3	terminal board with screw terminals resp. screwless terminal board (for version Modbus/Profibus)
POSITION	position scanning		
R _{in}	input resistance		
R _L	load resistance		
U _N	voltage for EPV		

Terminals for STR PA for DMS3:

PE, N, L - terminals (0,05-1,5 mm²) of supply (24 V AC resp. 110/120 V AC, resp. 230/240 V AC, 50/60 Hz (according to the specification – voltage and frequency are stated on nameplate of EA)
2, 3, 4 – terminals (max. 1,5 mm²) of supply of supply 3-phase motor 3x400 resp. 3x380 V AC
5,6 – terminals (max. 1,5 mm²) of supply of supply 3-phase motor 3x400 resp. 3x380 V AC
OP, CL – terminals (max. 1,5 mm²) of output of control for without reverse unit
0 V, +24 V – terminals (max. 1,5 mm²) of output voltage 24 V DC (40 mA)
COM, CLOSE OPEN, I1, I2 – terminals (0,05 - 1 mm²) of control inputs 24 V DC
+IN, -IN, SH – terminals (0,05 - 1 mm²) of unified input current signal or voltage signal
+L, -L, SH – terminals (0,05 - 1 mm²) of output current signal (passive) 4-20 mA
COM, NO, NC, NO, NO – terminals (0,05 - 1,5 mm²) of relay READY, relay R1 a R2 (on control unit)
COM5, NO5, NC5 – terminals (0,05 – 1,5 mm²) relay RE5 (on the module of the additional relays)
COM1, RE4, RE3, RE2, RE1 – terminals (0,05 - 1,5 mm²) relay RE4, RE3, RE2, RE1 (on the module of the additional relays)
COM, NO, NC – terminals (0,05 – 1,5 mm²) of relay READY (on the module of the additional relays)

Terminals for DMS3 Modbus/Profibus:

- screwless terminals are in separately terminal box. cross-section of connection wire 0,08 - 2,5 mm²
PE,N,U,V,W - terminals of supply voltage 230 V AC and 3x400 V AC
1,2,3,4,5,6 – terminals of single channel interface Modbus/Profibus
7,8,9,10,11,12 - terminals of duo channel interface Modbus/Profibus
21,22 – terminals of output voltage 24 V DC (40 mA)
13,14,15,16,17 – terminals of control inputs 24 V DC (40mA)

Note 1: On terminal N, L terminal power supply (X) feed supply voltage 230 V AC, or 24 V AC by you - specified type of construction EA. For supply voltage 24 V AC no need connect ground wire PE. For a version of EA with the supply voltage 3x400 or 3x380V, terminals N, L on terminal board of power supply (X) are fed by power supply 220 respectively 230 V AC.

*Note 2: Program possibilities for **R1, R2, RE1, RE2, RE3, RE4, RE5** relays: DISABLED, open position, close position, torque-open, torque – close, torque open or torque close, torque open or position open, torque close or position close, open, close, movement, movement flasher, to position, from position, warning, remote control, local control, control shut off, relay READY*

*Program possibilities for **READY** relay: errors, errors or warnings, errors or no remote, errors or warnings or no remote.*

*Program possibilities for output signal (from **EPV** passive): 4 to 20 mA, 20 to 4 mA.*

Control programme options (regulating)(not valid for with Modbus/Profibus protocol): 2P, 3P, 3P/2P switched over to I2

*Program possibilities for **input control signal (N)**: 4 to 20 mA (2 to 10 V), 20 to 4 mA (10 to 2 V), 0 to 20 mA (0 to 10 V), 20 to 0 mA (10 to 0 V).*

Program possibilities - for Modbus protocol

address – 1 247

baudrate [bit/s] – 1200, 2400, 4800, 9600, 19200, 38400, 57600, 115200

parity – even, odd, No

redundancy – off, Cable, Component, Repeater

connect time [s] – 0,1 25,5s

Program possibilities - for Profibus protocol

Address 1 – 1 ... 126

Address 2 – 1126

Redundancy: - Off, Simple

*Program possibilities for **inputs I1**: DISABLED, ESD, DBL (local releasing, remote releasing - not valid for EA without local control), STOP.*

*Program possibilities for **inputs I2**: DISABLED, ESD, DBL (local releasing, remote releasing), STOP
2P (when controller is switch on)(for control programme option 3P/2P I2)) allows control using the binary 24V DC inputs with I2 input activated.*

*Program possibilities of **FAILURE REACTION**: OPEN, CLOSE, STOP, SAFE POSITION.*

The identical functions cannot be set on I1 & I2 inputs in addition to the disabled state (e.g., if the ESD function is set on I1 input, it is not possible to select the (ESD) function on I2 input at the same time.

Relay READY on the control unit is doubled with relay READY on the module of the additional relays.

Relay R1 and relay R2 on the control unit is doubled with relay RE1 and relay RE2 on the module of the additional relays.

6.10 Dimensional drawings STR 1PA

P-1169 Flange DIN 3358

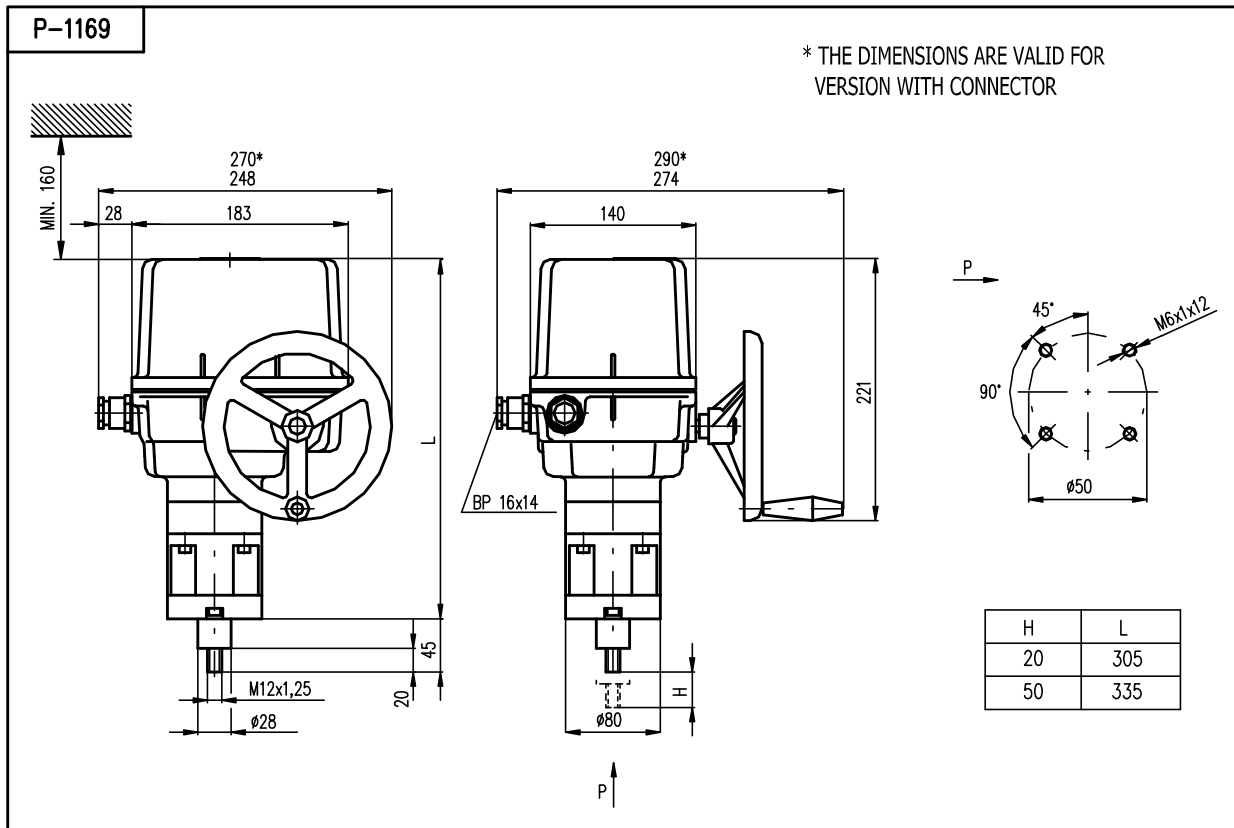

P-1170 Pillars

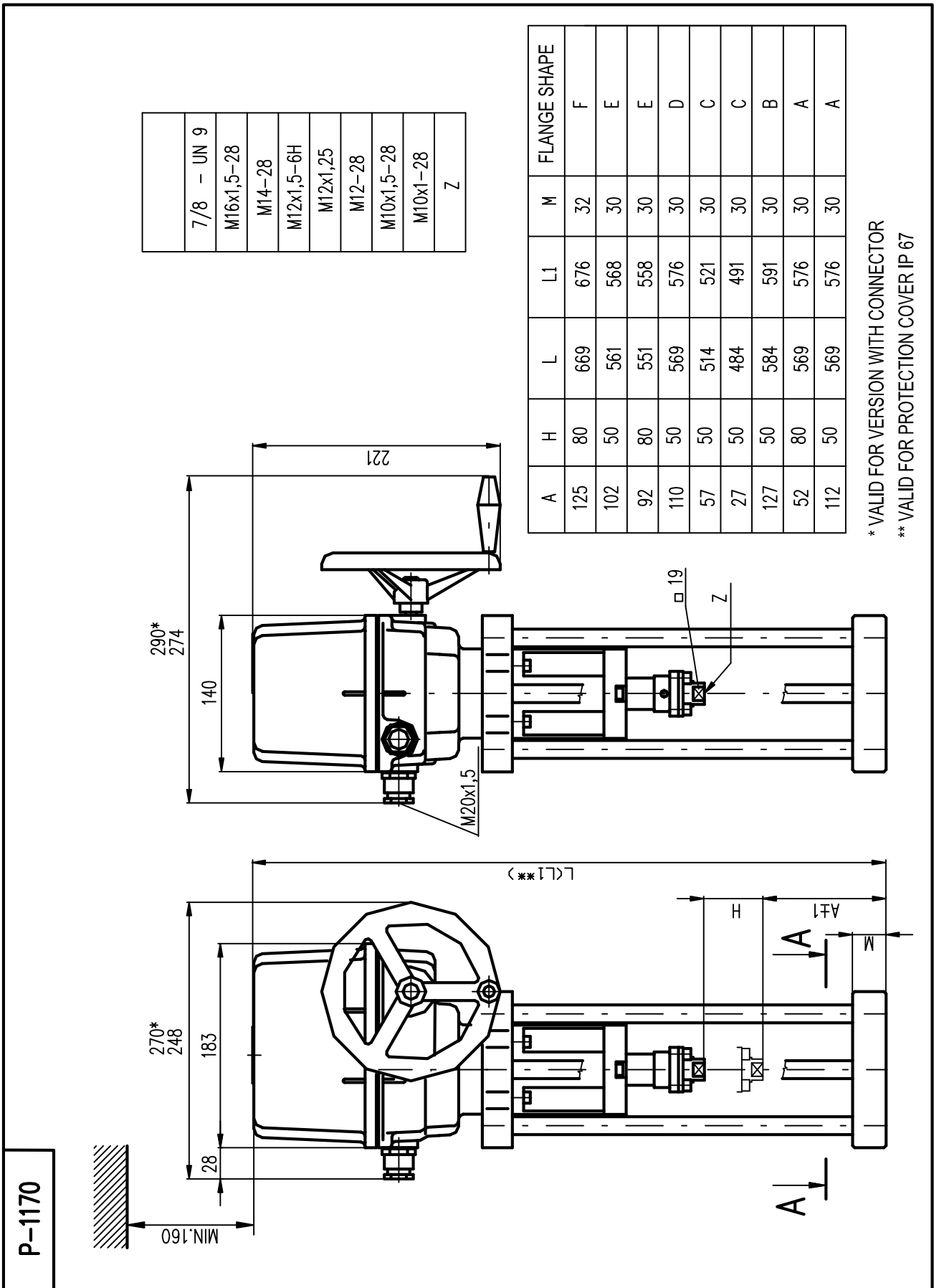

P-1170

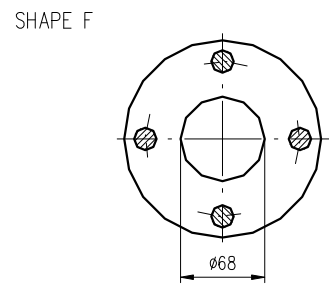
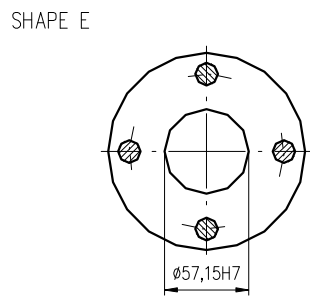
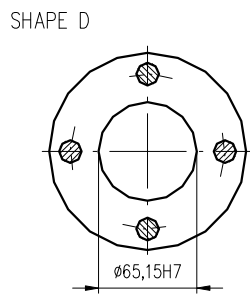
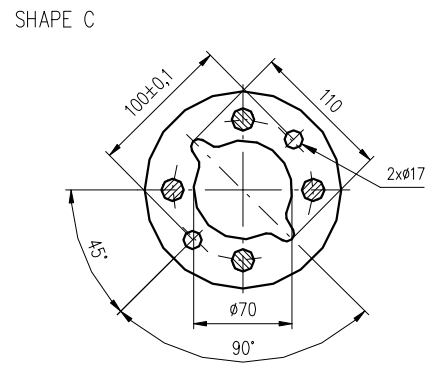
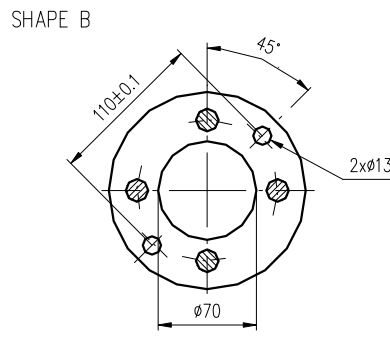
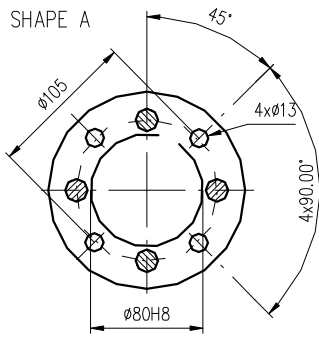

P-2046 - EA with local control

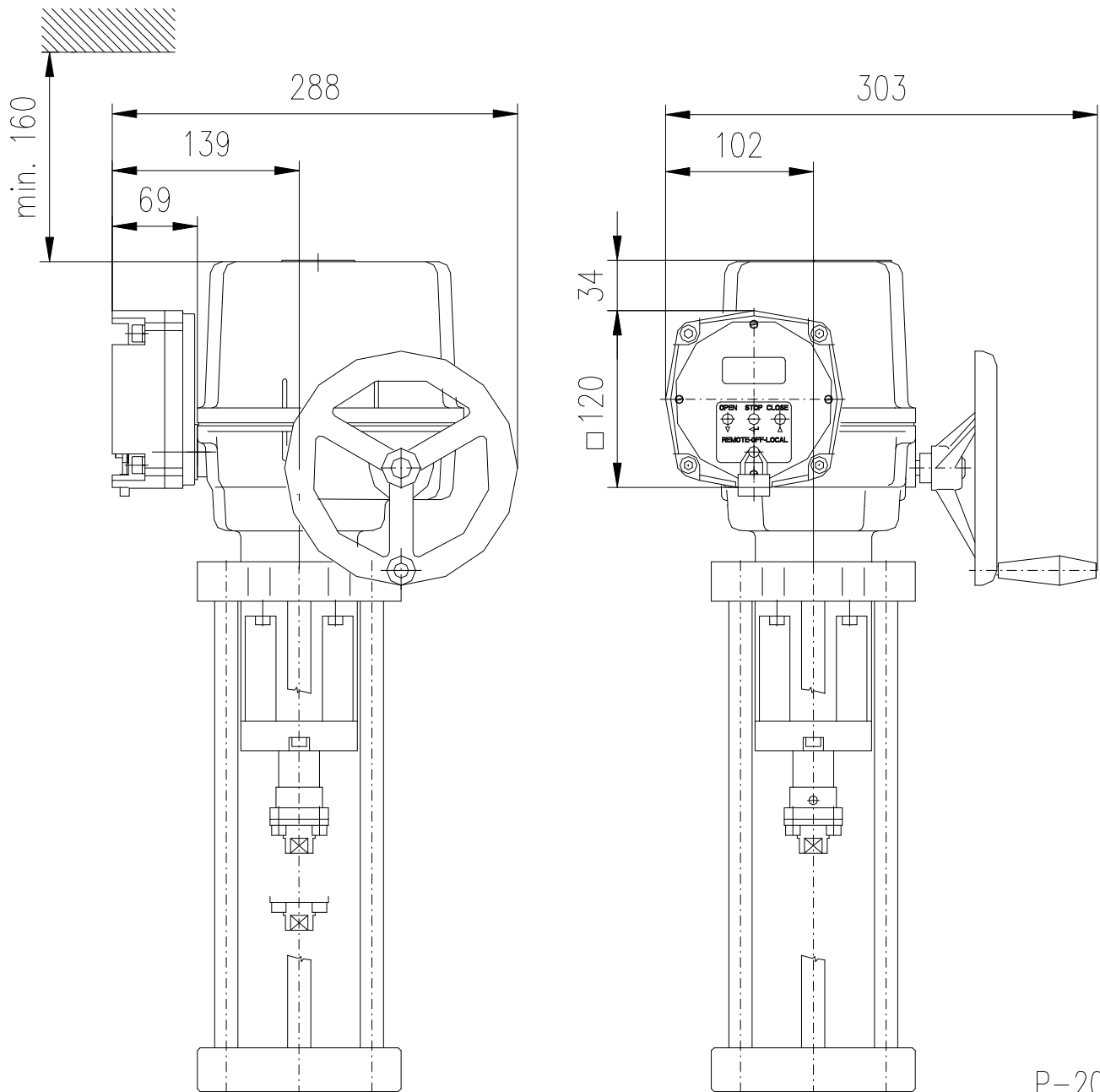

P-2046

6.11 Dimensional drawings STR 2PA

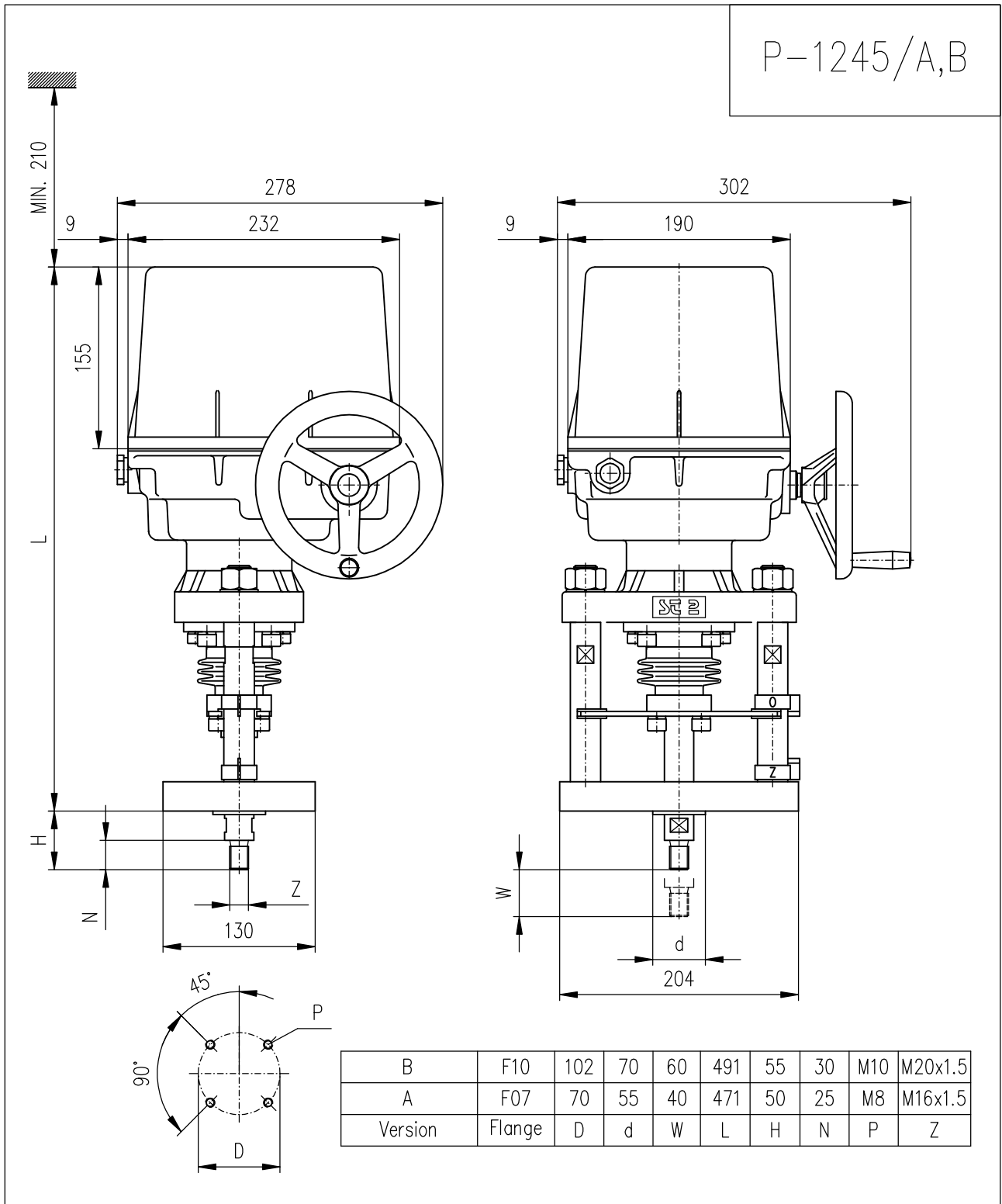

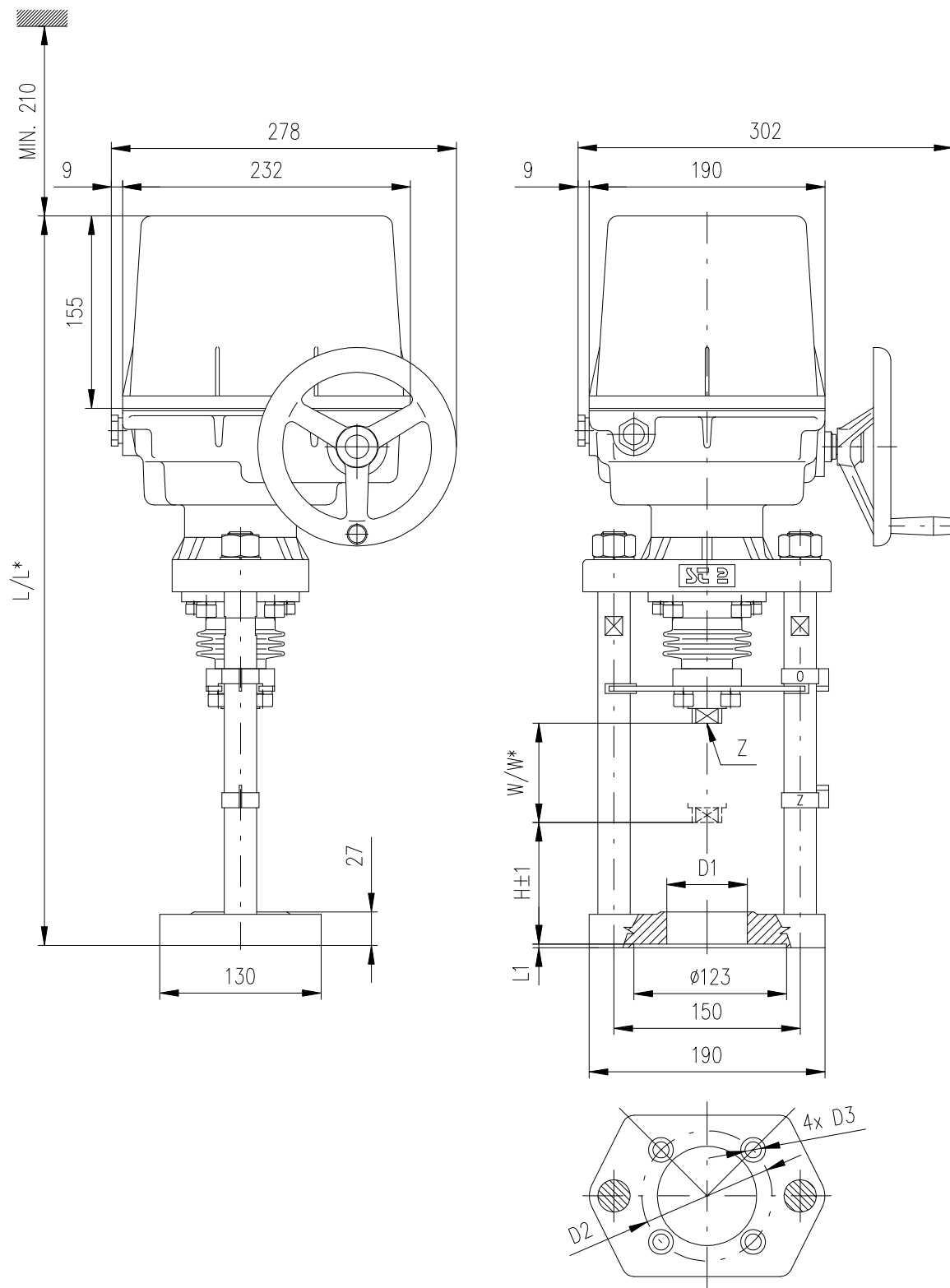

B	112	609/629	80/100	$\phi 80$	2	$\phi 105$	$\phi 13$	M20x1.5 M16x1.5 M14x2
A	110	609/629	80/100	$\phi 65H12$	3	-	-	
VERSION	H	L/L*	W/W*	D1	L1	D2	D3	Z

P-1246a/A,B

P-1246a/C	621 / -	-	32	125	80 / -	i 68	-	-	7/8"-UN9
Vyhotovenie (Version)	L / L*	L1	M	H	W / W*	D1	D2	D3	Z

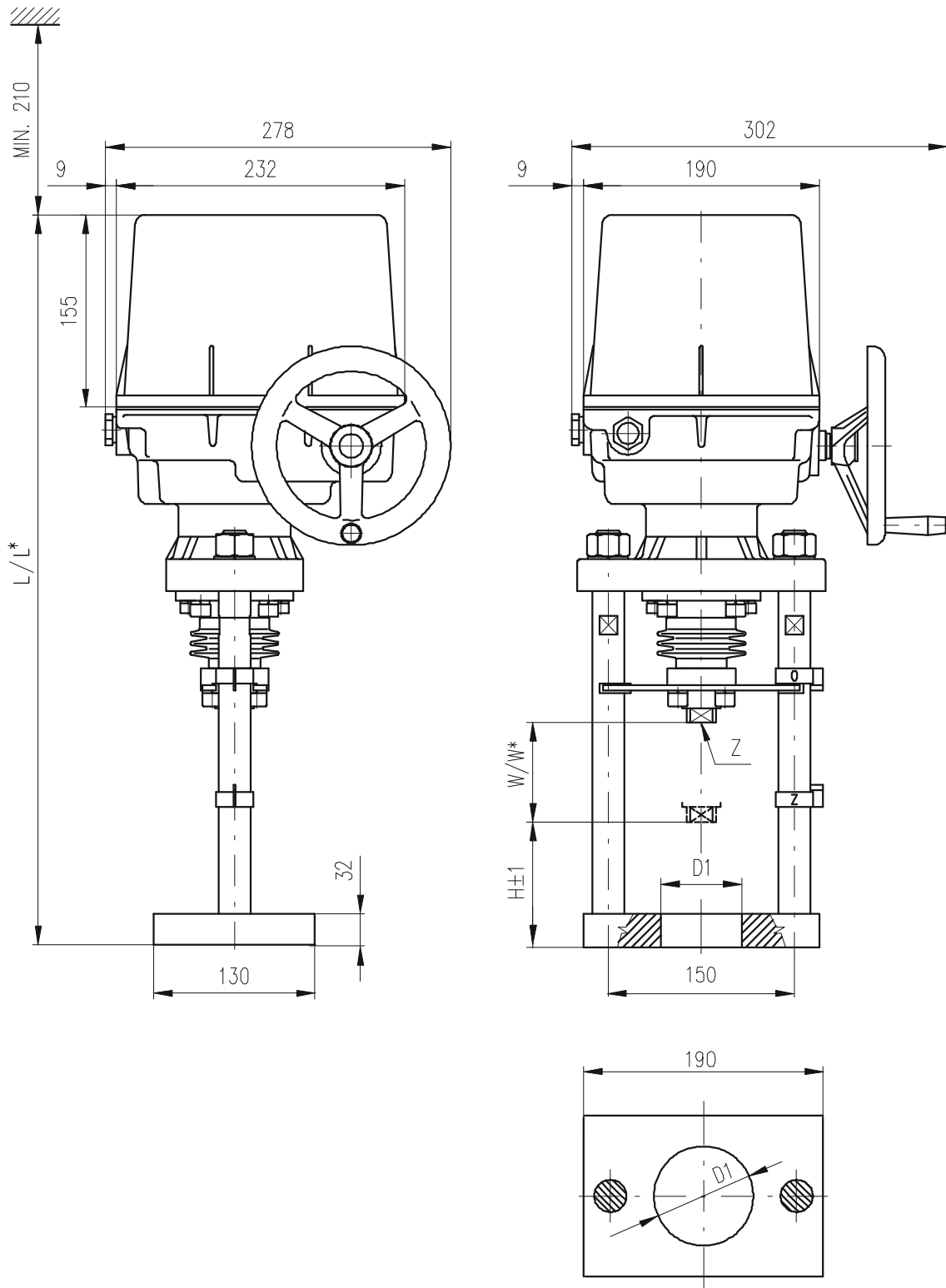

P-1246a/C

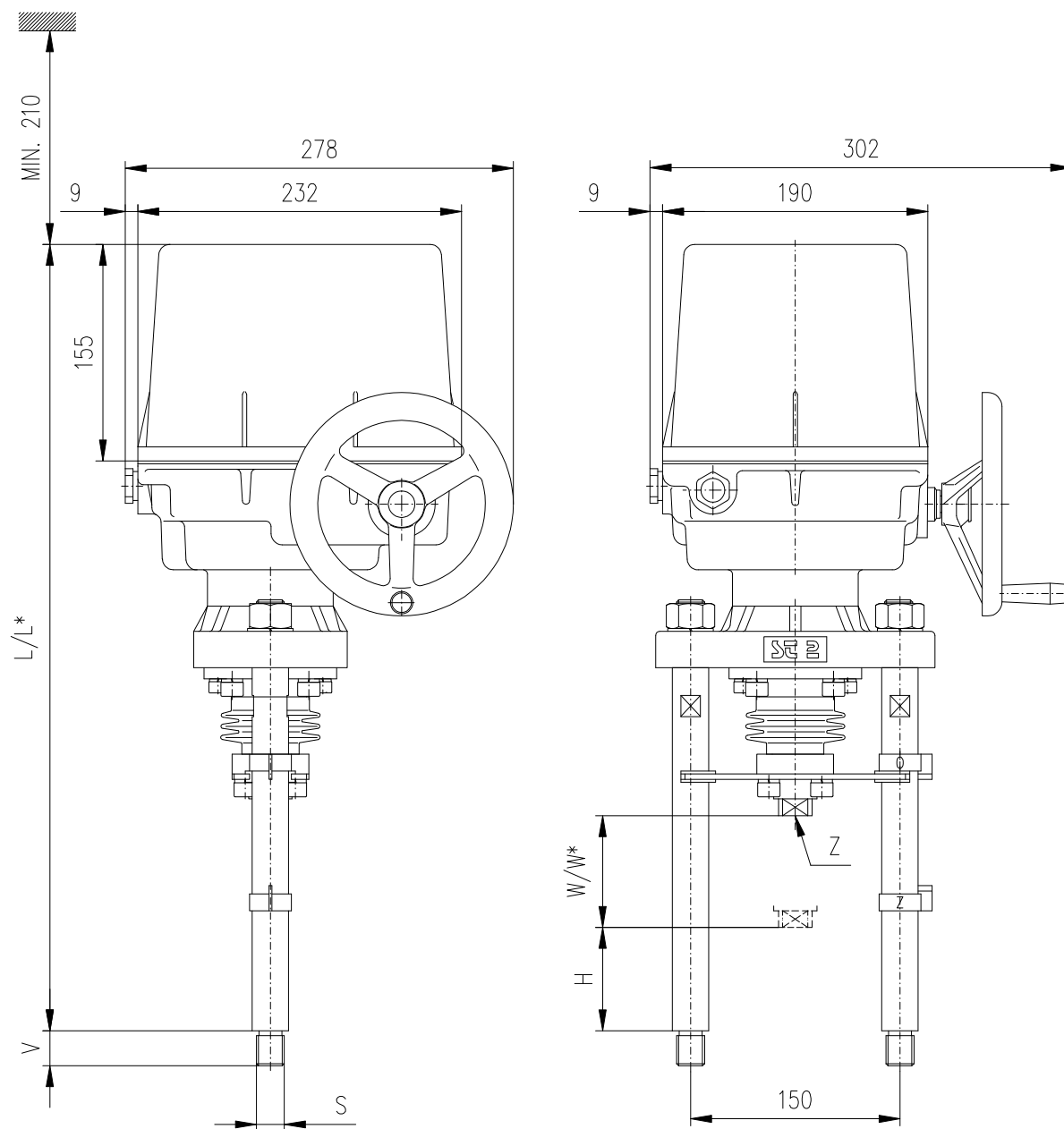

D	126	622/642	M20	25	MAX.80/MAX.100	M20x1.5 M16x1.5
C	74	570/590	M20	25	MAX.80/MAX.100	
B	30	526/546	M20	25	MAX.80/MAX.100	
A	92	588/608	M16	40	MAX.80/MAX.100	
VERSION	H	L/L*	S	V	W/W*	Z

P-1247a/A-D

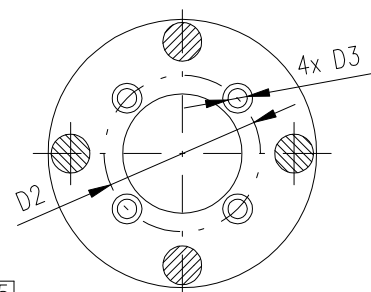
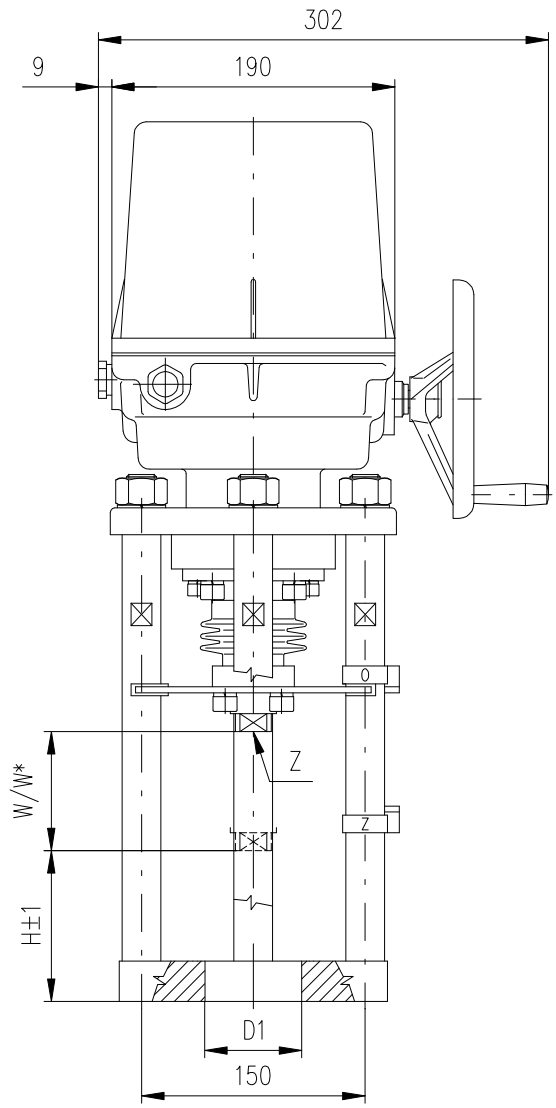
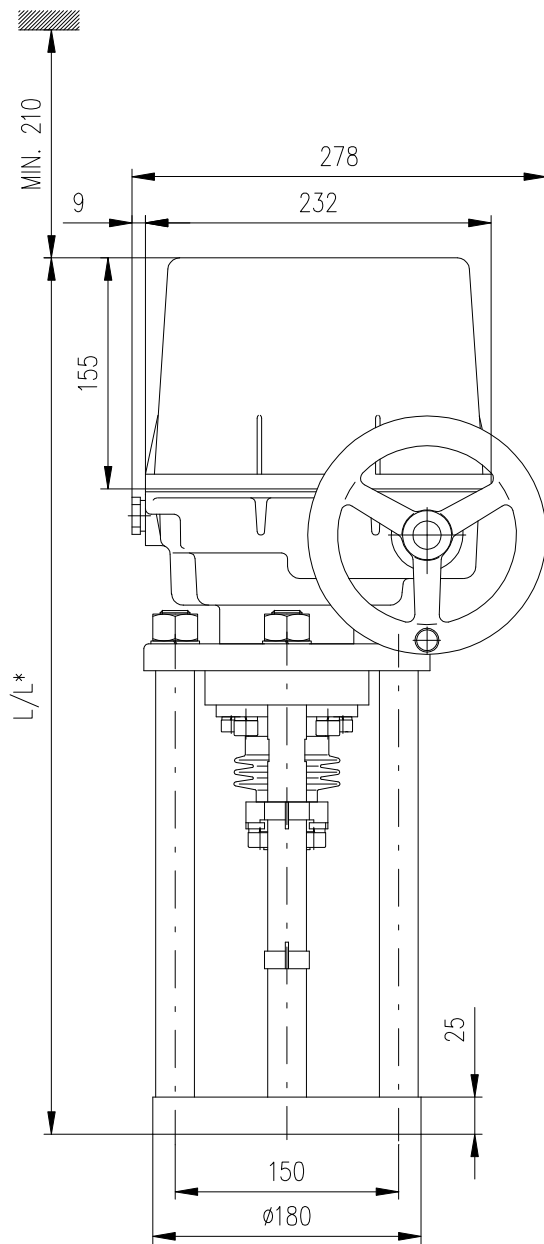

P-2000/B	112	609/629	80/100	ø80	ø105	ø13	M20x1.5
P-2000/A	110	609/629	80/100	ø65H12	-	-	M16x1.5 M14x2
VERSION	H	L/L*	W/W*	D1	D2	D3	Z

P-2000a

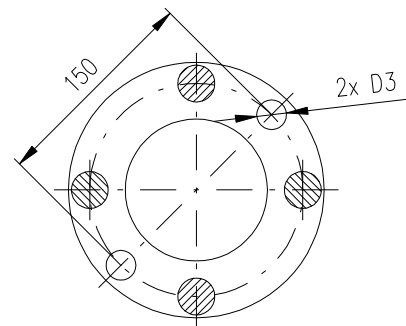
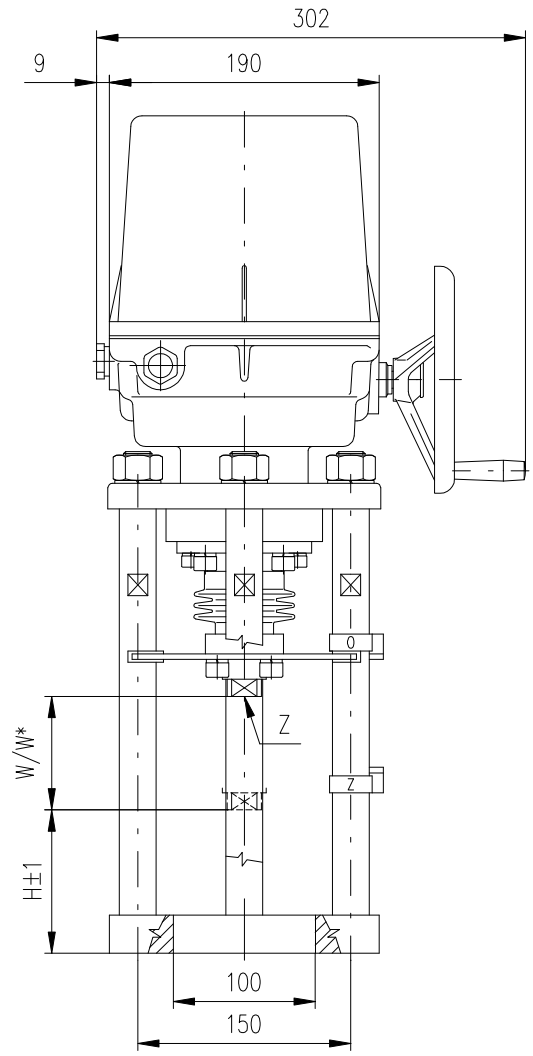
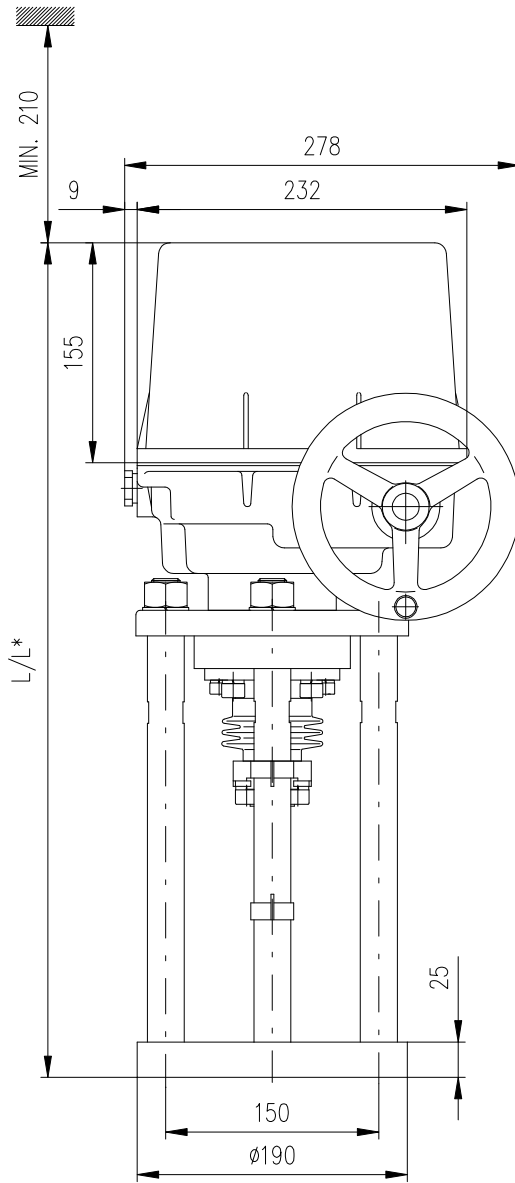

P-2001/D	126	622/642	MAX.80/MAX.100	M20	M20x1.5 M16x1.5
P-2001/C	74	570/590	MAX.80/MAX.100	M20	
P-2001/B	30	526/546	MAX.80/MAX.100	M20	
P-2001/A	92	588/608	MAX.80/MAX.100	M16	
VERSION	H	L/L*	W/W*	D3	Z

P-2001a

P-2047 Version with local electric control

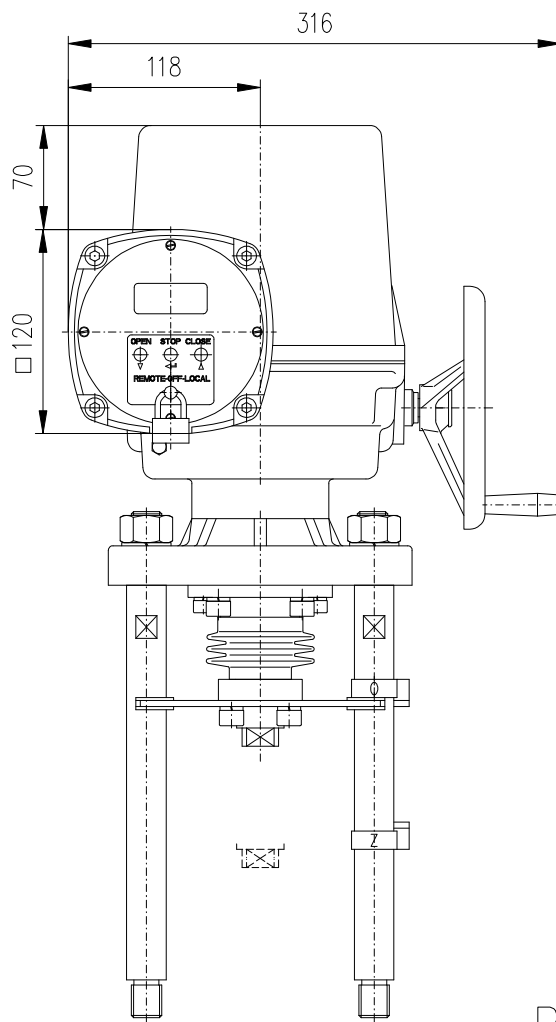
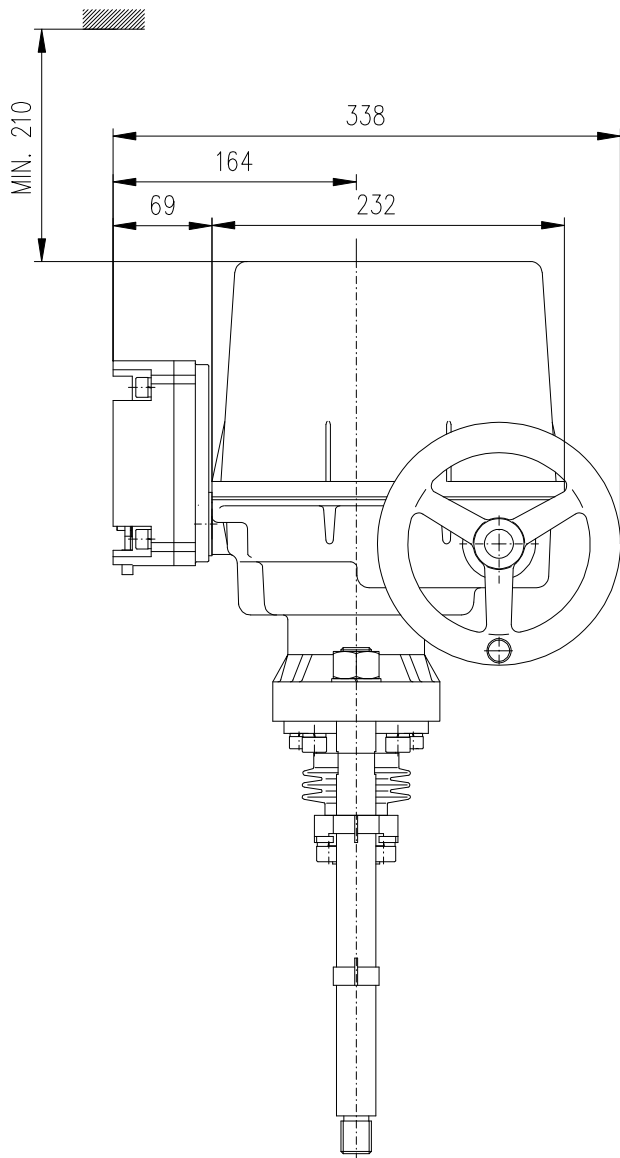

P-2047

6.12 Commercial representation

Slovak Republic:

Regada, s.r.o.,
Strojnícka 7,
080 01 Prešov
Tel.: +421 (0)51 7480 460,
Fax: +421 (0)51 7732 096,
E-mail: regada@regada.sk