

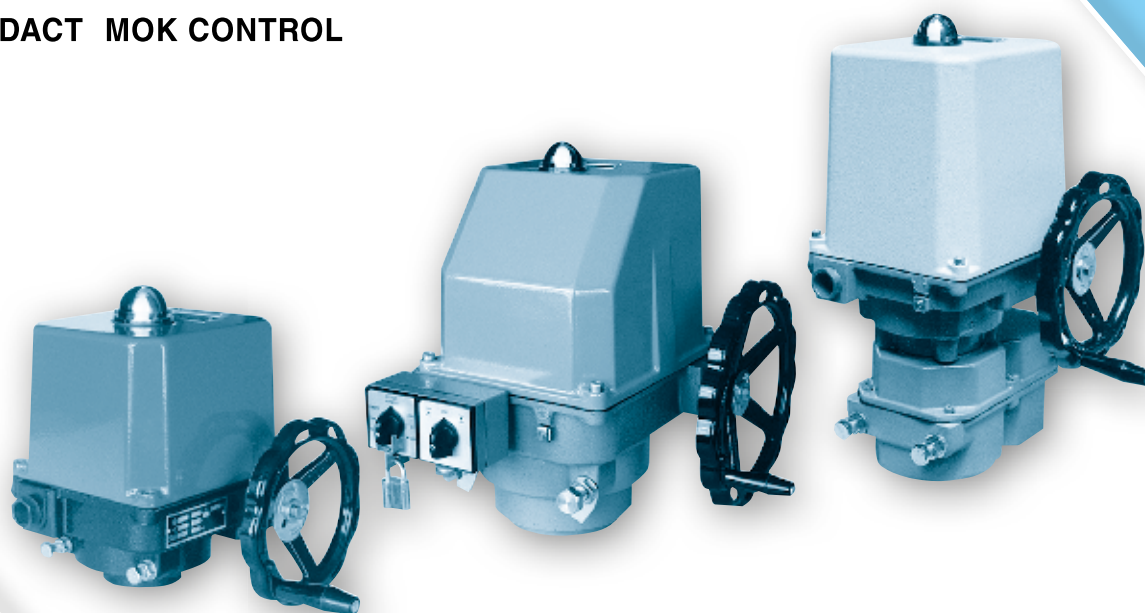

MODACT MOK 63 t.n. 52 325
MOK 125 t.n. 52 326
MOK 250 t.n. 52 327
MOK 500 t.n. 52 328
MOK 1000 t.n. 52 329

MODACT MOK CONTROL



INSTALLATION AND OPERATING
INSTRUCTIONS

**Electric Part-turn (90°) Actuators
for Ball and Flap Valves**

**MODACT MOK
MODACT MOK CONTROL**

Type Numbers 52 325 - 52 329



APPLICATION

The actuators **MODACT MOK** are designed for shifting control elements by a reversible rotary motion with the turning angle of the output part 90°, including cases when tight closure in end positions is required. Typical example of using is control of ball and flap valves in similar installations in the regime of remote control as well as automatic regulation. The electric actuators **MODACT MOK** are mounted directly on the controlled element.

OPERATING CONDITIONS, OPERATING POSITION

Operating conditions

The actuators **MODACT MOK (MODACT MOK Control)** are resistant against effect of operating conditions and external effects of classes AC1, AD5, AD7, AE5, AE6, AF2, AG2, AH2, AK2, AL2, AM-2-2, AN2, AP3, BA4 and BC3 according to ČSN 33 2000-5-51 ed. 3.

When the actuator is installed on a free area it is recommended to fit it with a light shelter against direct impact of atmospheric effects. The shelter should overlap the actuator contour by at least 10 cm at the height of 20 – 30 cm.

When actuators are to be installed in the working environment with temperature below +10 °C and in the environment with relative humidity above 80 %, it is always necessary to use an anti-condensation heater fitted to the actuator.

The electric actuators can be installed in areas with non-flammable and non-conductive dust, provided that this does not adversely influence their function. Here, it is necessary to strictly observe ČSN 34 3205. It is recommended to remove dust as soon as its layer is about 1 mm thick.

Notes:

The area under a shelter means the one where falling of atmospheric precipitations under and angle up to 60° from the vertical is prevented.

The electric actuator must be installed in a place where cooling air has a free access. Minimum distance from a wall for access of air is 40 mm. Therefore, the area where the electric actuator is installed must be sufficiently large, clean and ventilated.

Surrounding temperature

Operating temperature for the **MODACT MOK** is from -25 °C to +70 °C or from -60 °C to +60 °C.

Classes of external effects – excerpt from ČSN 33 2000-5-51 ed. 3.

Class:

- 1) AC1 – elevation above sea level ≤ 2000 m
- 2) AD5 – spouting water; water can spout in any direction
AD7 – shallow occurrence – shallow dipping
- 3) AE5 – medium dustiness
AE6 – strong dustiness
- 4) AF2 – occurrence of corrosive or polluting substances from atmosphere. Presence of corrosive polluting substances is significant.
- 5) AG2 – medium mechanical stress by impacts – common industrial processes
- 6) AH2 – medium mechanical stress by vibrations – common industrial processes
- 7) AK2 – serious risk of growth of vegetation and moulds
- 8) AL2 – serious danger of the occurrence of animals (*insects, birds, small animals*)
- 9) AM-2-2 – normal level of the signal voltage. No additional requirements
- 10) AN2 – medium solar radiation with intensities > 500 W/m² and ≤ 700 W/m²
- 11) AP3 – medium seismic effects; acceleration > 300 Gal ≤ 600 Gal
- 12) BA4 – personal abilities. Instructed people.
- 13) BC3 – frequent contact with the earth potential. Persons coming frequently into contact with "live" parts or standing on a conducting base.

Operating position

The actuators can be used in any operating position.

OPERATION MODE, SERVICE LIFE OF ACTUATORS

Operation mode

The actuators can be operated with the type of loading S2 according to ČSN EN 60 034-1. The run period at temperature +50 °C is 10 minutes; the mean value of loading torque should not exceed 60 % of the value of maximum tripping torque M_V . The actuators can also work in the regime S4 (*interrupted run with start-up*) according to ČSN EN 60 034-1. Load factor $N/N+R$ is max. 25 %; the longest working cycle ($N+R$) is 10 minutes (*course of working cycle is shown in the figure*). The highest number of closing operations in automatic regulation is 1200 cycles per hour. Mean value of loading torque with load factor 25 % and surrounding temperature +50 °C is not higher than 40 % of maximum tripping torque M_V .

The highest mean value of loading torque is equal to rated torque of the actuator.

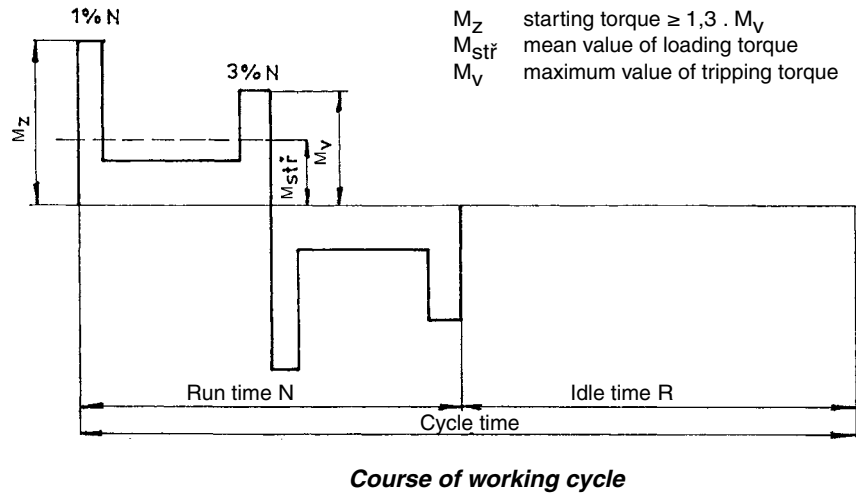

Service life of actuators

The actuator intended for shut-off valves must be able to perform at least 10,000 operating cycles (*C - O - C*).

The actuator intended for regulating purposes must be able to perform at least 1 million cycles with operation time (*during which the output shaft is moving*) at least 250 hours. Service life in operating hours (*h*) depends on load and number of switching. Not always, high frequency of switching influences positively accuracy of regulation. For attaining the longest possible faultless period and service life, frequency of switching is recommended to be set to the lowest number of switching necessary for the given process. Orientation data of service life derived from the set regulation parameters are shown in the following table.

Service life of actuators for 1 million starts

Service life [h]	830	1 000	2 000	4 000
Number of starts [1/h]	Max. number of starts 1200	1 000	500	250

TECHNICAL DATA

Supply voltage

Supply voltages of the actuators are shown in Table 1.

1 x 230 V, +10 %, -15 %, 50 Hz ± 2 %

3 x 230/400 V, +10 %, -15 %, 50 Hz ± 2 %

(or as shown on the motor rating plate)

Other supply voltage for electric actuators should be discussed with the manufacturer.

Protective enclosure

Protective enclosure of actuators **MODACT MOK**

IP 67 according to ČSN EN 60529.

Noise

Level of acoustic pressure A

max. 85 dB (A)

Level of acoustic output A

max. 95 dB (A)

Tripping torque

At the factory, the tripping torque has been adjusted as shown in Table 1, according to the customer's requirements. If no tripping torque adjustment has been specified by the customer the maximum tripping torque is adjusted.

Self-locking

The actuators are self-locking. Self-locking facility of the actuators is provided by a mechanical or electromagnetic brake of the electric motor.

Sense of rotation

When looking at the output shaft in the direction towards the control box, the CLOSE direction of rotation is identical with the clockwise sense.

Working stroke

The rated working travel of the actuator is 90°.

Manual control

Manual control is performed directly by a handwheel (*without clutch*). It can be used even when the electric motor is running (*the resulting motion of the output shaft is determined by the function of the differential gear*). When the handwheel is rotated clockwise the output shaft of the actuator also rotates clockwise (*when looking at the shaft towards the control box*). On condition that the valve nut is provided with left-hand thread, the actuator closes the valve.

Torque-limit switches in the actuator are set and work when the actuator is under voltage.

When using the manual control, ie. actuator is controlled mechanically, the torque-limit switches doesn't work and the valve can be damaged.

ACTUATOR OUTFIT

Torque-limit switches

The actuator is fitted with two torque-limit switches (*MO – OPEN, MZ – CLOSE*) each of which acts only in one direction of motion of the actuator output shaft.

The tripping torque can be adjusted within the range shown in Table 1.

Position-limit switches

The PO – OPEN and PZ – CLOSE position-limit switches limit the actuator working stroke, each being adjusted to operate in either end position.

Position signalling

For signalling position of the actuator output shaft, two signalling switches, i.e. the SO – OPEN signalling switch and the SZ – CLOSE signalling switch, are used. Each of these switches acts only in one direction of output shaft rotation. The operating point of the microswitches can be set within the whole working stroke range except the narrow band before the operating point of the microswitch used to switch off the electric motor.

Position transmitters

The **MODACT MOK** electric actuators can be supplied without position transmitter or can be fitted with position transmitter:

a) Resistance transmitter 1 x 100 Ω.

Technical parameters:

Position scanning	resistance
Turning angle	0° – 320°
Non-linearity	≤ 1 %
Transition resistance	max. 1.4 Ω
Permitted voltage	50 V DC
Maximum current	100 mA

b) Type CPT 1Az passive current transmitter. Power supply to the current loop is not a part of the actuator. Recommended feeding voltage is 18 – 28 V DC, at maximum loading resistance of the loop 500 Ω. The current loop should be earthed in one point. Feeding voltage need not be stabilized; however, it must not exceed 30 V or else the transmitter could be damaged.

Range of CPT 1Az is set by a resistance transmitter on the transmitter body and its starting value by corresponding partial turning of the transmitter.

Technical parameters of CPT 1Az:

Scanning of position		capacity
Working stroke		adjustable 0° – 40° to 0° – 120°
Non-linearity		≤ 1 %
Non-linearity, including gears		≤ 2.5 % (for a maximum stroke of 120°)
Hysteresis, including gears		≤ 5 % (for a maximum stroke of 120°)
<i>(The non-linearity and hysteresis are related to a signal value of 20 mA).</i>		
Loading resistance		0 – 500 Ω
Output signal		4 – 20 mA or 20 – 4 mA
Supply voltage	for R _{load} = 0 – 100 Ω	10 to 20 V DC
	for R _{load} = 400 – 500 Ω	18 to 28 V DC
Maximum supply voltage ripple		5 %
Maximum transmitter power demand		560 mW
Insulation resistance		20 MΩ at 50 V DC
Insulation strength		50 V DC
Operational environment temperature – extended range		-25 °C to +70 °C (additional on demand)
Dimensions		ø 40 x 25 mm

c) Type DCPT active current transmitter. Power supply to the current loop is not a part of the actuator. Maximum loading resistance of the loop is 500 Ω. For variants **MODACT MOK Control** with the regulator ZP2RE4, it is used as a position sensor.

DCPT can be easily set by two push-buttons with LED diode on the transmitter body.

Technical parameters of DCPT:

Scanning of position		contact-less magneto-resistant
Working stroke		adjustable 60° – 340°
Non-linearity		max. ±1 %
Loading resistance		0 – 500 Ω
Output signal		4 – 20 mA or 20 – 4 mA
Power supply		15 – 28 V DC, < 42 mA
Working temperature		-25 °C to +70 °C
Dimensions		ø 40 x 25 mm

For the transmitters CPT 1Az as well as DCPT, a two-wire connection is used, i.e., the transmitter, the power supply and the load are connected in series. The user should secure that the two-wire circuit of the current transmitter is connected to the electric earth of the associated regulator, computer, etc. This connection should only be made at a single point in any section of the circuit, outside the actuator.

Position indicator

The actuator is fitted with a local position indicator.

Anti-condensation heater

The actuators are fitted with an anti-condensation heater preventing condensation of water vapour. It is connected to the AC mains of voltage 230 V.

Local control

Local control serves for controlling the actuator from the site of its installation. It includes two change-over switches: one with positions “Remote control - Off - Local control”, the other “Open - Stop - Close”. Switch 1 can be integrated as 2-pole or 4-pole switch.

ELECTRIC PARAMETERS

External electric connection

The terminal board of the actuator is fitted with terminals allowing one conductor with a maximum cross-section of 2.5 mm² or two conductors with the same cross-sectional area up to 1 mm² to be connected.

Connecting of actuators with connector – on special request.

Actuator internal wiring

The internal wiring diagrams of the **MODACT MOK** actuators with terminal designation are shown in this Mounting and operating instructions.

Each actuator is provided with its internal wiring diagram on the inner side of the actuator cover. The terminals are marked on a self-adhesive label attached to a carrying strip under the terminal block.

Overheating protection of electric motor

All electric motors have thermal fuses in their winding. They serve as an additional protection; they do not substitute the overcurrent protection or circuit breaking.

The fuses of single-phase electric motors are internally interconnected with the winding and, in case of overheating, they cut out the electric motor; after cooling down, they cut it in automatically.

The fuses of three-phase electric motors are separately led out and they can be connected into control or signalling circuits. They are connected to the actuator terminal board as a standard for **MOK 63** (type no. 52 325) only.

Load-bearing capacity is 250 V AC / 2.5 A.

Current rating and maximum voltage of microswitches

Maximum voltage of mikroswitches is 250 V AC as well as DC, at these maximum levels of currents.

MO, MZ 250 V AC / 2 A; 250 V DC / 0,2 A

SO, SZ 250 V AC / 2 A; 250 V DC / 0,2 A

PO, PZ 250 V AC / 2 A; 250 V DC / 0,2 A

The microswitches can only be used as single-circuit devices. Two voltages of different values and phases cannot be connected to the terminals of the same microswitch.

Isolation resistance

Isolation resistance of electric control circuits against the frame and against each other is min. 20 MΩ. After a dump test, isolation resistance of control circuits is min. 2 MΩ. Isolation resistance should be at least 1,9 MΩ. See Technical specifications for more details.

Electric strength of electric circuits isolation

Circuit of resistance transmitter 500 V, 50 Hz

Circuit of current transmitter 50 V DC

Circuits of microswitches and anti-condensation heater 1 500 V, 50 Hz

Electric motor Un = 1 x 230 V 1 500 V, 50 Hz

Un = 3 x 230/400 V 1 800 V, 50 Hz

Deviations of basic parameters

Tripping torque ±15 % of the maximum tripping torque

Operating time of the output part - 10 %
+15 % of the rated value (in no-load operation)

Hysteresis of position limit and signalling switches ≤4°

Adjustment of working travel ±1°

Clearance of the output part

actuators, Type Nos 52 325, 52 326, 52 328 1.5° max.

actuators, Type Nos 52 327, 52 329 2.5° max.

Protection

The electric actuators are fitted with external and internal protecting terminal for securing protection against dangerous shock voltage.

The protecting terminals are marked according to ČSN IEC 417 (34 5550).

If actuator is not provided with over-current protection when purchased, such protection must be provided externally.

TECHNICAL DESCRIPTION

The MODACT MOK (*MODACT MOK Control*) actuators consist of the following two parts:

- **Power section** constituted of a one-phase or three-phase asynchronous motor (see Tab. 1), a countershaft gearbox, an epicyclic gear with the output shaft, a manual control mechanism with a handwheel and a floating worm and, in the actuators, Type Nos 52 327 and 52 329, an output gearbox (*with adapter*) with a 1:2 gear ratio.

- **Control section** which is identical for all MODACT MOK actuators, Types MOK 125 to MOK 1000 type no., with the only exception that, it differs in angular displacement of units on the base plate. In the actuator, Type No. 52 325, the unit of position-limit signalling switches is arranged as shown in Fig 1. The control section (*Fig.1*) consists of position-limit switching unit 1, residence position transmitter 2, torque-limit switching unit 3, terminal block 4 and anti condensation heater 8.

The position-limit switching unit uses 4 microswitches of which 2 are always used for either direction of rotation of the output shaft. The switching point of each microswitch can be adjusted independently within the working travel range of the actuator.

The torque-limit switching unit has independently adjustable microswitches, one for either direction of rotation. The torque-limit switches are not secured against opening at the startig torque.

The potentiometer is fitted with a slipping clutch to permit automatic adjustment along with the output shaft.

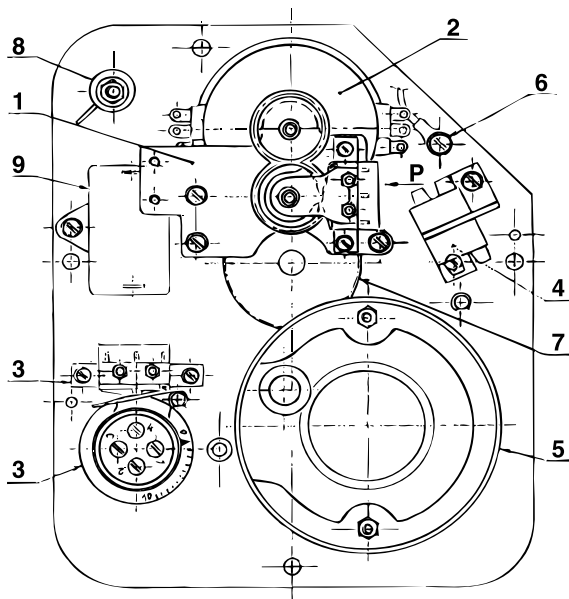

Fig. 1 - Control panel (type no. 52 325)

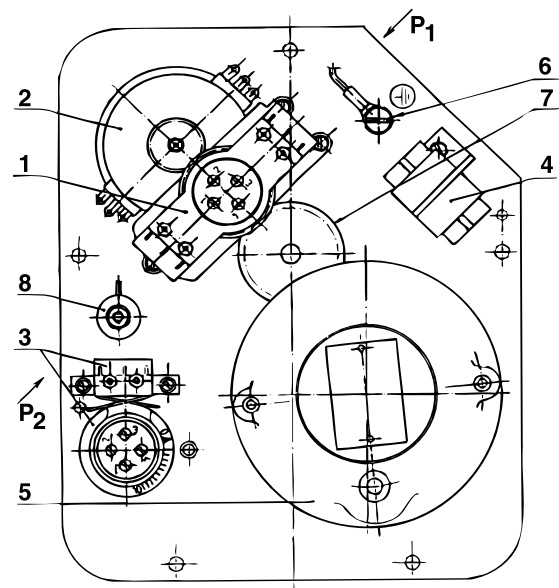
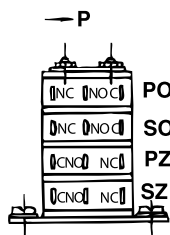
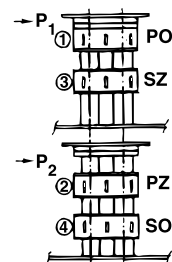

Fig. 1 - Control panel (type no. 52 326 - 52 329)



Legend:

- 1 - Position-limit switching unit
- 2 - Position transmitter (potentiometr)
- 3 - Torque-limit switching unit
- 4 - Terminal board
- 5 - Electric motor
- 6 - Internal protective terminal
- 7 - Drive gear (or segment)
- 8 - Anti-condensation heater
- 9 - Starting capacitor



Note:

The encircled numbers are identical to the numbers of the cam releasing screws of the position-limit switching unit.

The anti-condensation heater 8 (Fig. 1, 2) prevents water vapours from condensing under the cover of the control section. The position-limit switching unit and the position transmitter derive their movements from the output shaft of the actuator via a driving gear (or in the actuators, Type Nos 52 326 and 52 327, via driving segment 7, as shown in Fig. 1). The torque-limit switching unit is driven by a "floating worm" of the manual control mechanism where the worm displacement is directly proportional to the torque of the actuator output shaft. This enables the actuator to be switched off immediately the torque on the output shaft to which the torque-limit switching unit has been adjusted, is reached.

Note: The microswitches used are of a single-chamber type, i.e., they can operate as a one-pole cut-out switch a contact maker or a change-over switch, whereas the torque-limit switches can be used as cut-out switches only (see the respective circuit layout).

ADJUSTMENT OF THE ACTUATOR

a) Stop screws

Stop screws are used to limit the actuator working travel to 90° in compliance with the CLOSED and OPEN end positions of the valves having no trip dogs of their own. The screw stops are mounted on the outside of the actuator along with the external protective terminal. When viewing the stop screws, the right-hand stop screw is designed for the CLOSED position, whereas the left-hand stop screw is designed for the OPEN position under the assumption that, when viewing the local position indicator, the output shaft rotates clockwise in the CLOSE direction of rotation. For adjustment of the stop screws, loosen the stop screws, move the actuator with valve into the CLOSED position, and turn the corresponding stop screw till an increased resistance is felt when the screw runs onto the stop face within the actuator. Secure the stop screw in position by retightening its lock nut. Then, rotate the output shaft of the actuator through a 90° angle to bring it into the OPEN position and set the OPEN-position stop screw by the same procedure.

When setting the stop screws in the actuators, Type Nos 52 326 and 52 327, care should be taken to ensure that, in the CLOSED or OPEN end position, the driving gear segment of the position-limit switching and auxiliary signalling units cannot strike the electric motor. In either end position of the output shaft of the actuator, the local position indicator should tally with the marks on the index plate.

If the valve is required to be tightly closed in the end position and thus the actuator is to be switched off by means of the torque-limit switches, the tripping torque should be transferred to the valve. In this case, set the corresponding stop screw so that the valve is properly sealed when the stops of the output shaft run against the stop screw at which the torque-limit switch operates.

In this case, the respective torque-limit switch is used for switching off the actuator. If stops are required to be used for protection of the actuator and the valve against damage in the case of a failure of the position-limit switch set the stop screws to such a position which ensures dependable operation of the position-limit switch and is still permissible for the valve. In this case, the position-limit switch and the torque-limit switch should be connected in series. Nevertheless, this can only be done when no tight closure of the valve is required.

b) Position-limit switches

Position-limit switches PO, PZ switch off an electric actuator when the output shaft reaches the position for which they are set. Signalling-limit switches SO, SZ signalise the position of electric actuator output shaft.

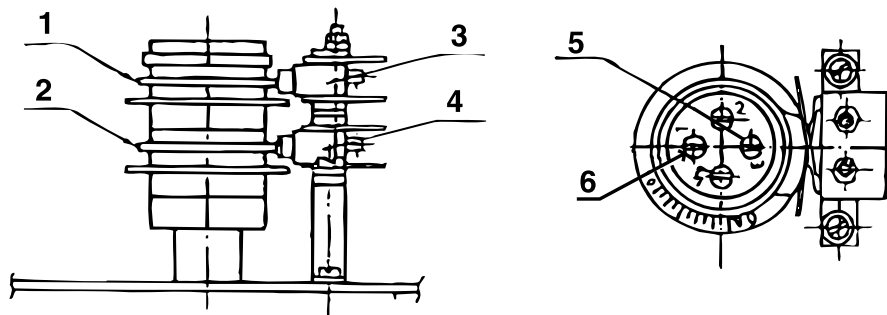

Legend:

- 1 – OPEN torque-limit switch cam
- 2 – CLOSE torque-limit switch cam
- 3 – OPEN torque-limit switch
- 4 – CLOSE torque-limit switch

- 5 – Releasing screw of CLOSE torque-limit switch cam
- 6 – Releasing screw of OPEN torque-limit switch cam

Fig. 3 - Torque-limit switches

The setting of position-limit switches is carried out by positioning the output shaft into the position in which the set switch should switch off. Then, loosen the micro-switch cam using the releasing screw.

Loosening will be done by turning the releasing screw counter-clockwise. Turn the releasing screw only until the cam is released. By further turning of the releasing screw, you would tighten the cam again. Numbers of relevant releasing screws are on a holder of position unit (Fig. 1) and they correspond to markings on a cam shaft.

When loosened, turn the cam in the opposite direction to the motion of an electric actuator output shaft while setting the position "open" or "closed" until the micro-switch switches over. In this position lock the cam by tightening the releasing screw (clock-wise direction).

A signalling switch must be set so that it switches over sooner than a relevant position-limit switches or torque-limit switches. When adjusting position-limit and signalling switches of electric actuators Type Nos. 52 326 and 52 327, ensure that a gear segment of position and signalling unit drive in the extreme position "open" or "closed" doesn't hit the actuator case. A position unit of electric actuator Type No. 52 325 is not equipped with the locking of cams using screws (Fig. 2). The cam's position on the shaft is ensured only by friction which has to be overcome when adjusting the cams. A design Type No. 52 325 has cams locked by friction and central milled nut with contra-nut which must be loosened before adjusting and tightened properly again after adjusting.

c) Position transmitter

To adjust the potentiometer it is sufficient to set the actuator output shaft to any of the OPEN or CLOSED end positions. In this way, the potentiometer is automatically preset. The automatic adjustment of the potentiometer is usually provided already when the stop screws or the position-limit switches are adjusted.

Current position transmitter CPT 1Az – setting

Before starting setting the current transmitter it is necessary to set the end-limit positions (torque or position switches) of the actuator and connect them into the tripping circuit of the electric motor. In case of an external source of feeding voltage, verification must be carried out that it does not exceed the maximum value 30 V DC (limit value when CPT 1Az is still not damaged). Recommended value is 18 – 28 V DC.

Positive pole of the source is connected to the positive pole of the transmitter CPT 1Az; a milli-ammeter of precision at least 0.5 % connected into the circuit. The current loop must be earthed in one point. The figure does not show the earthing that can be made at any point of the circuit.

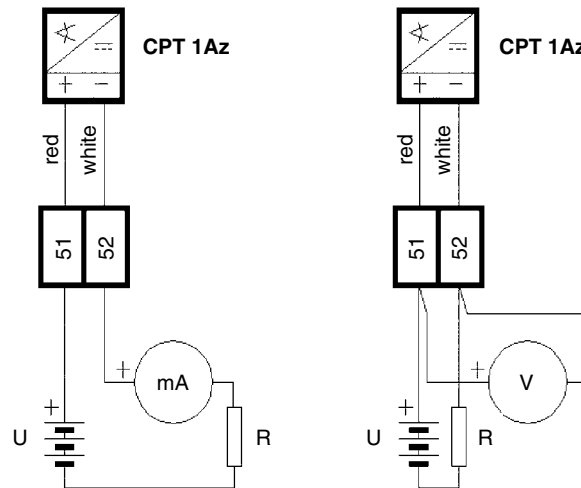

1. Shift the output shaft into the position Closed. During closing, the current signal value should decrease. If it increases release the transmitter body and, by turning of about 180°, shift to the descending part of the output characteristics. Set 4 mA by fine turning. Tighten the shim plates to secure the transmitter against spontaneous turning.
2. Shift the output shaft to the position Open and set 20 mA using a potentiometer on the transmitter body. The potentiometer has a range of 12 revolutions and it has no stops so that it cannot be damaged by further turning.
3. Once again verify the current value in the position Closed. If it has changed too much repeat the points 1. and 2. If the required corrections are large this procedure should be repeated several times. After the setting, secure the transmitter against turning and drip the screws with varnish.
4. Use a voltmeter to check the voltage on the CPT 1Az terminals. In order to keep linearity of the output signal the voltage must not drop below 9 V, not even with off-take 20 mA. If this condition is not met it is necessary to increase the feeding voltage (within the range of recommend values) or to decrease total resistance of the current loop R.

Caution!

The transmitter CPT 1Az must not be connected without checking the supply voltage. The transmitter outlet conductors must neither be connected to the electric actuator frame nor to the earth, not even accidentally.

Before the supply voltage is checked, it is first necessary to disconnect the transmitter from the supply mains. Measure the voltage on terminals of the electric actuator to which the transmitter is connected – this can best be done using a digital voltmeter of input resistance at least 1 MΩ. This voltage should fall within the range of 18 – 25 V DC; in no case may it exceed 30 V (*otherwise the transmitter can be damaged*). Then, connect the transmitter so that the positive pole of the power source is connected to the positive pole of the transmitter, i.e. to the pin with red insulator (*r*) + (*nearer to the transmitter centre*). The terminal with white coating (*wired to the terminal 52*) is connected to the negative pole of the transmitter (*white insulator*). In the latest design variants the red conductor is plus and the black one is minus.

A milli-ammeter, preferentially a digital one with accuracy at least 0.5 %, is temporarily connected in series with the transmitter. The output shaft is moved to the position CLOSE. The signal value should decrease. If this is not the case, the output shaft should be rotated in the CLOSE direction until the signal starts decreasing and the output shaft reaches the CLOSE position.

Then, loosen the screws of the transmitter shim plates so that the whole transmitter can be turned to set the current to 4 mA, and retighten the screws of the shim plates. Thereafter, move the output shaft of the electric actuator to the position OPEN. Using the resistance trimmer on the transmitter face (*nearer to the edge*) set the current to 20 mA. The trimmer has 12 turn and no stops. Hence, it cannot be damaged.

In case the correction of the current 20 mA was considerable repeat adjustment for 4 mA and 20 mA once again. Disconnect the milli-ammeter. The screw secured by a drop of varnish situated nearer to the centre must not be turned. Retighten the countershafts fixing the transmitter shim plates and secure with a drop of varnish against loosening.

After completing the adjusting procedure, check voltage on the transmitter terminals using a voltmeter. The voltage should fall within the range of 9 – 16 V with current 20 mA.

Note:

The transmitter characteristics has two branches: the descending one and the ascending one with respect to the CLOSE position. The characteristics is selected by turning the transmitter body.

Current position transmitter DCPT – setting**1. Set of end-limit positions**

Before starting the setting, verification must be carried out that the end-limit positions are within the range 60° – 340° of revolution DCPT. Otherwise, after setting, an error arises (*LED 2x*).

1.1. Position “4 mA”

Set the drive into the required position and press the push-button “4” until LED blinks (*about 2 s*).

1.2. Position “20 mA”

Set the drive into the required position and press the push-button “20” until LED blinks (*about 2 s*).

2. Setting of sense of rotation

The sense of rotation is specified by viewing from the side of the panel DCPT.

2.1. Rotating anti-clockwise

Press the push-button “20”, then the push-button “4” and keep them depressed until LED blinks.

2.2. Rotating clockwise

Press the push-button “4”, then the push-button “20” and keep them depressed until LED blinks.

When the sense of rotation is changed the end-limit positions “4 mA” and “20 mA” remain valid but the working range (*track DCPT*) between these points is changed to a complement of the original working range. In this way, the permitted working range can be exceeded (*LED 2x*) – it can be smaller than 60°.

3. Error messages

In case of an error the diode LED blinks an error code:

1x	Sensor position out of working range
2x	Working range incorrectly set
3x	Off the tolerance level of magnetic field
4x	Wrong parameters in EEPROM
5x	Wrong parameters in RAM

4. Calibration of currents 4 mA and 20 mA.

On switching-on the power supply, keep the push-buttons “4” and “20” depressed and release them after a single blink of LED. In this way the option menu 4.1 Calibration of current 4 mA is entered.

4.1. Calibration of current 4 mA

Connect the ammeter to testing terminals. Press the push-button “20”. Keep depressed the push-button to evoke the auto-repeat of current decrease. Release the push-button to make record of the present value.

4.2. Calibration of current 20 mA

Connect the ammeter to testing terminals. Press the push-button “4”. Keep depressed the push-button to evoke the auto-repeat of current increase. Release the push-button to make record of the present value.

4.3. Switching-over between option of calibration 4 mA and 20 mA

Entry of option of calibration 4 mA:

Press the push-button “4”, then the push-button “20” and keep them depressed until LED blinks.

Entry of option of calibration 20 mA:



Press the push-button “20”, then the push-button “4” and keep them depressed until LED blinks.

5. Record of standard parameters

On switching-on the power supply, keep the push-buttons “4” and “20” depressed and release them after a double blink of LED.

ATTENTION! With this record, the transmitter calibration is also overwritten and, therefore, it must be repeated!!

Parameter setting

Position “4 mA”	
Set the actuator to required position (<i>usually Closed</i>) and keep the push-button 4 depressed until LED blinks.	
Position “20 mA”	
Set the actuator to a required position (<i>usually Open</i>) and keep the push-button 20 depressed until LED blinks.	

d) Torque-limit switches

The torque-limit switches have been adjusted to the specified torque at the factory. If they are required to be readjusted to another torque, release the corresponding cam by means of the cam releasing screws whose numbers are given in the legend of Fig. 3. By the linear division of the respective scale section between the zero and the maximum switching torque as marked on the scale in colour, we obtain a point for the required switching torque with which the arrowhead on the cam should tally. Retighten the cam releasing screw. For manipulation of the releasing screws of the torque-limit switches, the same applies as to the releasing screws of the position-limit switching unit. After the torque-limit switches have been adjusted, check that they operate using a lamp tester.

Caution! Any manipulation of the releasing screws numbered 2 and 4 is forbidden.

POSITION REGULATOR ZP2.RE VERSION 4

Electric regulators of position of output shaft ZP2 are used in the actuators MODACT Control. They provide for controlling the actuator in which they are built in by analog input signal from the superior control system.

Basic component of the regulator is a microcomputer with control program in its internal memory.

The microcomputer includes:

- A/D converters for input and feedback signals processing.
- Memory of parameters.
- Power supply source with mains transformer.
- Output relays for controlling the actuator (*they switch on the electric motor or power switches*).
- Input circuits for connection of end micro-switches and contact of thermal relay.
- Circuits for input of analog signals.
- Push-buttons and signal lamps which can be used for entering parameters of regulation (*the signal lamps serve also for indication of regulation state and type of errors*).
- Connectors for connection of the regulator with the actuator.
- Connector for service connection of the regulator with PC.

The regulator has the following functions:

- Parameters of regulation can be entered by push-buttons on the regulator or from PC with is connected to the regulator via a communication module.
- After entering the parameters of regulation, auto-calibration is accomplished during which the regulator is finding parameters of the actuator and the valve.
- After auto-calibration has been completed, the regulator stores the entered and measured parameters into the memory of parameters.
- Input and feedback signals and state of end micro-switches are checked.
- The actuator is controlled according to the input and feedback signals, state of end micro-switches, regulation parameters and parameters of the actuator.
- It monitors and records into its memory of parameters total operation time and total number of closings of the output relays.
- It ascertains whether, during regulation or setting the regulator, any failure occurs; if so, the type of failure is evaluated and indicated; according to entered parameters, the regulator sets the actuator output shaft and stores the parameters of the found-out failure into its memory.
- It provides for connecting PC which can be used for entering parameters of regulation and monitoring the regulator operation.

The program memory is of ROM type, the memory of parameters of regulation and parameters of the actuator is of EEPROM type; consequently, the memory content is not damaged by switching off mains voltage.

Speed of rotation of the actuator output shaft is given by the actuator type and variant; it cannot be influenced by the regulator.

Connection of actuator with regulator and three-phase electric motor to mains voltage

The actuator with three-phase electric motor should be connected to mains voltage so that it is stable during operation with regulator; i.e. if the actuator is in a balanced position and is brought out of this position by an external intervention (*e.g. by the hand wheel*) it is automatically brought back to this balanced position by action of the regulator. Therefore, a correct sequence of phases of mains voltage should be observed.

Moreover, position and moment switches of the actuator should be correctly connected so that drive of the actuator is switched off by particular switch when either of the limit positions of the output shaft is reached (*unless switching off has already been performed by the regulator*).

Attention: *If the actuator is connected to three-phase voltage with opposite phase sequence than that one with which it has been set and tested, it starts to be unstable, i.e. the actuator output shaft is brought to one of its limit positions. When the limit position is reached, the actuator electric motor is not switched off as, in this case, the limit micro-switch acts on the contactor for motion in opposite direction. In this way, the actuator or the controlled valve can be damaged.*

The sequence of phases can also be changed during repairs and modifications in circuits of distribution of three-phase voltage for feeding actuators!

After the mains voltage is connected to the actuator, the actuator can spontaneously be started even if control signal has not yet been connected to the regulator as the regulator has evaluated this state as an error and the output shaft of the actuator is set according to the entered parameter.

In case that the connected mains voltage has opposite sequence of phases than that for which the actuator has been set in the factory, the actuator does not stop even if the limit switches have been opened.

Therefore, during installing and putting the actuator into operation, measures should be adopted that spontaneous starting of the actuator cannot happen even in case that mains voltage is accidentally switched

REGULATOR ZP2.xx

Layout of indicator LEDs, push-buttons, terminals and connectors

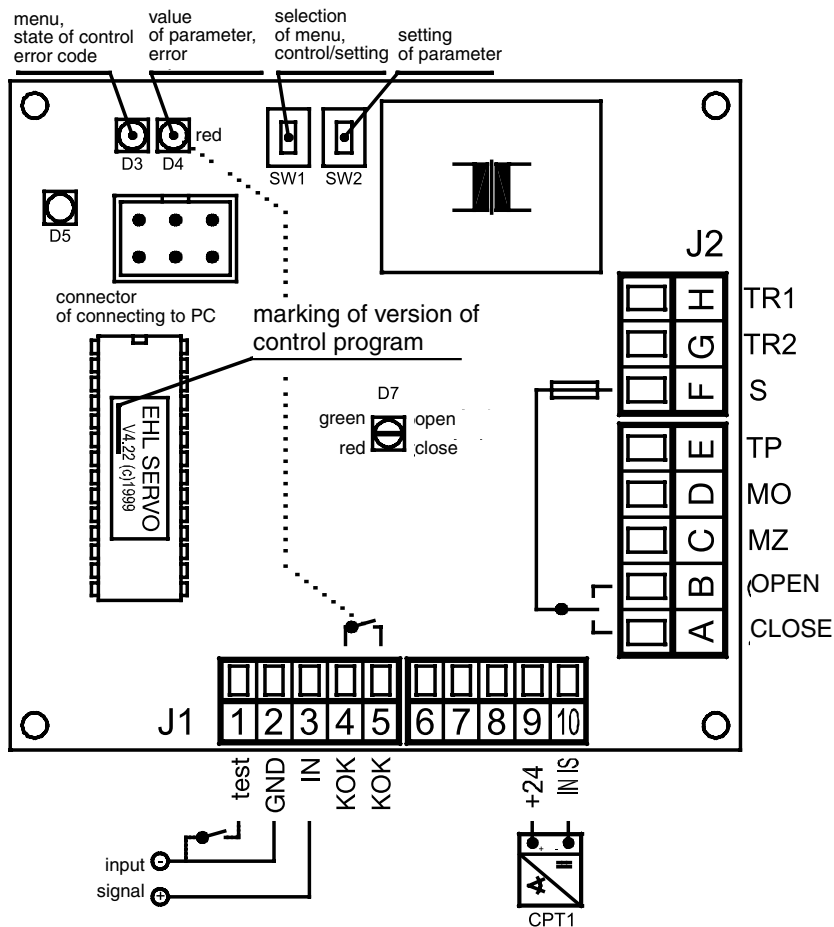

J1 - signal terminal board

- | | | |
|----|-------|--|
| 1 | test | input of logic control signal test |
| 2 | GND | control signal - negative pole |
| 3 | IN | control signal - positive pole |
| 4 | KOK | switching contact of error report |
| 5 | KOK | switching contact of error report |
| 6 | | |
| 7 | | |
| 8 | | |
| 9 | +24 V | feeding of current position transmitter |
| 10 | IN IS | signal from current position transmitter |

J2 - power terminal board

- | | | |
|---|-------|--------------------------|
| A | OPEN | power output "Open" |
| B | CLOSE | power output "Close" |
| C | MZ | limit switch "Closed" |
| D | MO | limit switch "Open" |
| E | TP | thermal fuse |
| F | S | feeding of power outputs |
| | | 1) MOK 63, 125, 250 L1 |
| | | 2) MOK 500, 1000 N |
| G | TR1 | feeding of regulator |
| H | TR2 | |

Note: The signals MO, MZ, TP and "Test" are input signals; neither the signal TP nor "Test" need to be connected. Active level (a level evaluated by the regulator as an error state) of the signals TP and "Test" different from that set by the regulator manufacturer or by ZPA Pečky a.s. can only be set by the computer.

on during connecting the actuator. The actuator can be switched off by the push-button "TEST" on the thermal relay. In the actuators **MODACT Control MOK 500** and **1000** it is installed under the actuator cover. The push-button can be pressed e.g. by a small screwdriver. After the push-button has been pressed, feeding of coils of power relays is interrupted and the actuator stops.

The actuator feeding is restored by pressing the large red push-button on the thermal relay.

A longitudinal sight hole is provided on the upper side of the thermal relay which is used for monitoring the relay condition. If drive of the actuator is switched off by action of the thermal relay - by the push-button TEST or as a result of over-loaded electric motor, a yellow target is visible under the sight hole. By pressing the large red push-button the yellow target disappears.

Attention! Even after this switching off the actuator circuits are under voltage. Before any works on the actuator, e.g. change of phase sequence in the actuator terminal board, the mains voltage should be disconnected.

Note: In the auto-calibration regime the regulators ZP2 version 4 perform testing of the sense of rotation and report the incorrect direction as an error. The sense of rotation is not tested in the regulation regime.

TECHNICAL PARAMETERS OF REGULATOR

Supply voltage	230 V +10 % -15 %, 50 – 60 Hz	
Control signal	analog 0 – 20 mA, 4 – 20 mA, 0 – 10 V	
	logical – TEST, contact from the superior system (<i>simulation of breakdown situation</i>)	
	– MO, MZ state of actuator limit switches *)	
Output signal	power outputs	2x relay 8 A, 230 V, protected by a fuse F1, 8 A
	central breakdown (<i>KOK contact</i>)	– pilot-light switch 24 V, 2 W
	5x LED	(<i>power supply, breakdown, setting, opening, closing</i>)
	brake	control signal 2 mA (<i>signal for additional module</i>)
	actuator position	PWM (<i>signal for additional module</i>)
Position transmitter	current transmitter 4 – 20 mA **)	
Regulator linearity	0.5 %	
Regulator in-sensitivity	1 – 10 % (<i>adjustable</i>)	
Error messages	TEST mode	
	reaction transmitter failure limit switches are transposed *)	
	missing control signal actuator has been switched off by a limit switch in the interposition *)	
Respond to failure	reaction transmitter failure	actuator to Test position, error message
	missing control signal	actuator to Test position, error message
	TEST mode	actuator to Test position, error message
Setting elements	communication connector (<i>for computer connection</i>)	
	2x button for setting parameters without a computer	
Range of operating temperatures	-25 °C – 75 °C	
Dimensions	75 x 75 x 25 mm	

*) A limit switch means a position switch or moment switch of actuator connected so that it can stop the actuator motion in given direction. During the auto-calibration, the regulator ZP2 measures the reaction signal at which limit switches switch off the actuator (for both motion directions) and stores it in the memory as the parameter. While regulating, the limit switch status is being permanently monitored. If the actuator is switched off by the limit switch in the position which does not correspond to the position ascertained during the auto-calibration, the regulator will analyze this state to be an error. Such a state can occur e.g. when the moment switch is used as the limit switch and valve seizes in the course of regulation.

***) If a two-wire current transmitter (e.g. CPT1 type) is used, the transmitter is supplied with the supply voltage of 24Vss if the signal is brought out from the actuator it is active.

Setting of regulator parameters by functional push-buttons

After fitting the actuator with the regulator on the valve, proper function of the regulator is to be ensured by setting parameters of the regulator and starting auto-calibration; this can be best carried out when the piping where the valve with actuator is fitted is filled with process medium.

The regulator parameters can be set by push-buttons on the regulator (*the parameter being set is indicated by LED diodes D3, D4 on the regulator*) or by PC connected to the regulator.

This manual serves as instructions for setting parameters of the regulator ZP2.RE version 4 (*marking on the label of the case of the regulator single-chip computer, e.g. EHL SERVO V4.28" 2004*) by push-buttons. Special instructions are to be issued for setting the regulator by the computer (*the computer can also be used for setting other parameters than those described in these instructions and various diagnostic data can be obtained*).

Before setting the parameters, limit switches of the actuator must be connected and adjusted and the position transmitter must be set. If moment switches are used as limit switches it is necessary to ensure that the actuator or the valve can produce required tripping moment.

The parameters of the regulator cannot be set as long as the actuator shaft is in one of its extreme positions and if it is switched off by the limit switch; auto-calibration would not be performed and the regulator would report an error. Therefore, before setting the parameters, the actuator must be adjusted - e.g. by the hand wheel - so that the output shaft is in an intermediate position (*i.e. in a position when the actuator is normally not switched off by any of the limit switches*).

Setting of parameters

In setting the parameters according to these instructions, change over to the setting regime by keeping the push-button **SW1** pressed until the yellow diode **D3** on the regulator is lit on (*about 2 s*). Then, release the push-button SW1 and parameters on the regulator can be set (*list through the menu depicted by the yellow diode D3 by short pressing SW1, set the parameters depicted by the red diode D4 by short pressing the push-button SW1*) - see the following Menu 1 - Menu 5. If, by pressing the push-button **SW2**, the latest value of the parameter in the particular menu is selected another pressing of the push-button **SW2** will bring you back again to the first value of this parameter. In this way you can select values of parameters in cycles according to the list for the given parameter. After particular value of the parameter has been selected, press the push-button **SW1** shortly. The selected value of the parameter is acknowledged and the following menu is chosen.

If, by gradual pressing the push-button **SW1**, the MENU 5 is reached the following short pressing of the push-button **SW1** will return you again to the MENU 1 (*another pressing to MENU 2, etc.*). In this way, the set parameters can be checked and changed during setting).

Always when red diode **D4** is lit on - during regulation, auto-calibration and in setting parameters - the contact KOK (terminals J1-4, J1-50) is closed.

The diodes D3 and D4 give a signal by the number of flickering.

Menu 1: Setting control signal

D 3 (yellow)	☉	
D 4 (red)	☉	0 – 20 mA
	☉☉	4 – 20 mA
	☉☉☉	0 – 10 V

Menu 2: Setting response to signal Test and in case of failure

D 3 (yellow)	☉☉	
D 4 (red)	☉	opens
	☉☉	closes
	☉☉☉	no response

Menu 3: Setting mirroring (*ascending/descending characteristics*)

D 3 (yellow)	☉☉☉	
D 4 (red)	☉	higher signal - CLOSED (<i>descending characteristics - mirroring</i>)
	☉☉	higher signal - OPEN (<i>ascending characteristics - no mirroring</i>)

Menu 4: Setting insensitivity of regulator

D 3 (yellow)	☉☉☉☉	
D 4 (red)	☉	1 %
	☉☉	2 %

	☉☉☉☉☉☉☉☉☉☉☉☉☉☉☉☉	10 %

Menu 5: Setting way of regulation

D 3 (yellow)	☉☉☉☉☉	
D 4 (red)	☉	narrow to moment
	☉☉	narrow to position
	☉☉☉	broad to moment
	☉☉☉☉	broad to position

By the regulation “to position” the actuator shaft is set to the position in which the input and feedback signals are equal.

The regulation “to moment” means that, in setting the input signal close to limiting positions - for the signal 4 – 20 mA this is up to the value of about 4.2 mA and above 19.8 mA (*these values are fix set and cannot be changed*), the actuator shaft is not stopped when the input and feedback signals are equal but it goes on moving until it is stopped by action of the particular limit switch. Such setting is used in case that tight closing of the valve in the limit position is safely ensured.

“Narrow” regulation means that, during the regulation, the actuator shaft is set so that the signal from the position transmitter corresponds exactly to the input signal. In case, after the actuator is stopped, the feedback signal does not correspond to the input signal the actuator is switched over to the so-called step regime; it reaches an exact position by repeated switching on and off of the electric motor.

“Broad” regulation means that the actuator shaft is set so that, after the actuator stops, the difference between the input and feedback signal is smaller or equal to the set range of insensitivity.

If the regulator need not be set otherwise it is recommended to set the way of regulation as “broad to position”.

After setting, checking and possible correcting the parameters, the push-button SW1 should be kept pressed (*this can be done in any menu*) until the diode D3 is lit on. In this way, setting of parameters is completed and it is acknowledged that the set parameters are valid and can be stored in the regulator memory. After releasing the push-button SW1, the auto-calibration is automatically started.

Auto-calibration is an automatic process in which the regulator performs checking of the position transmitter, sense of rotation of the actuator output shaft, changes over the actuator into the position “Open” and “Closed”, measures feedback signals in these positions, measures inertia in the direction “Opens” and “Closes”, and stores the set and measured parameters into the regulator memory.

The auto-calibration should always be started in case of a change of conditions which can influence the regulator performance, e.g. in case of a change in setting the limit switches of the actuator or a change in mechanical properties of the valve, e.g. if the gland is tightened.

Menu 6: Auto-calibration (*error messages*)

D 3 (*yellow*) ☼☼☼☼☼☼☼☼

D 4 (*red*) no flickering

auto-calibration in progress

☼☼☼☼

auto-calibration starts at the limit switch, failure of limit switch

☼☼☼☼☼☼

error in connecting limit switches

☼☼☼☼☼☼☼

position transmitter connected in wrong way or defective

☼☼☼☼☼☼☼☼☼☼

wrong sense of the shaft rotation

In case of wrong connection of the regulator (*limit switches or position transmitter wrongly connected*) the auto-calibration will be interrupted and the regulator will announce an error by means of the diodes **D3** and **D4**. If everything is OK then, after the auto-calibration is completed, the regulator is switched over to the regulation regime.

IMPORTANT!

In case the setting of parameters and auto-calibration have not been accomplished without an error the set parameters are not stored in the memory of the regulator. After the error is repaired, the setting of parameters and the auto-calibration can be repeated.

If the regulator parameters are set before the valve with the actuator have been installed on the piping, then, after their installation and filling the piping with the working medium, properties of the complete can be changed in such a way that the setting of the regulator and starting of auto-calibration should be repeated.

Program RESET of regulator

If the regulator is brought to a state which is to be cancelled (*RESET*), e.g. for returning from the setting menu without auto-calibration, this can be accomplished by pressing the push-button **SW1** and keeping it pressed down for at least 6 s.

Note:

If an error occurs in the auto-calibration this procedure does not function: the error conditions should be cancelled by switching off and on the feeding voltage of the regulator. If the new regulator or the regulator into which wrong parameters have erroneously been set cannot be started, they can be put into the initial state by switching off the feeding voltage for about 0.5 min (*to provide for discharging the filtering capacitors in the power supply source*); then, keep pressed both push-buttons on the regulator, with the push-buttons pressed down switch on feeding voltage to the regulator and keep the push-button pressed down for 6 s. In this way, data which allow putting the regulator into operation and carrying-out new setting of parameters are counted into the regulator memory.

Important warning:

This procedure can be used in setting the parameters the setting of which cannot be changed without a connected computer (e.g. voltage level on TP input in which the regulator changes over into an error state - this can cause problems in the actuators **MODACT MOK 500** and **1000** where it is necessary to set an opposite active level than the one set by the regulator manufacturer). It is, therefore, not recommended to use the RESET function if the changed parameters cannot be newly set by the computer.

Process and error messages of regulator during regulation

Process messages:

D 4 (red)	lit off	
D 3 (yellow)	lit on	regulator regulates
	lit off	regulation deviation within the insensitivity range

Error messages:

If an error occurs which can be detected by the regulator the contact KOK connected to the terminals J1-4 and J1-5 is closed; the diode D4 is lit on permanently. The regulator response to the error is given by the set parameter "Response to signal TEST". The diode D3 reports the type of error by the flickering code:

D 4 (red)	permanently	lit on
D 3 (yellow)	☼	regime TEST
	☼ ☼	control signal in the range 0 – 10 V missing
	☼ ☼ ☼ ☼	actuator switched off in intermediate position by limit switches
	☼ ☼ ☼ ☼ ☼	failure of position transmitter
	☼ ☼ ☼ ☼ ☼ ☼	failure in thermal protection
	☼ ☼ ☼ ☼ ☼ ☼ ☼	control signal in range 4 – 20 mA is lower than 3 mA or missing.

After the cause of the error conditions has been repaired, the regulator is automatically switched over to the regulation regime.

INSTALLATION AND PUTTING INTO OPERATION

After unpacking the actuator, check that no visible damage was caused during the transport or storing. When no visible cause has been detected connect the actuator to external control and power supply circuits. At the midpoint of the working stroke, start the actuator for a short time to make sure that its output shaft rotates in the correct direction. For this check, depress the lever of the corresponding position-limit or torque-limit microswitch (depending on the control mode) while the actuator operates in a certain direction, using a rod of insulating materials. If the actuator fails to stop, but is arrested only on operation of the microswitch used for the opposite direction of rotation, the sense of rotation of the actuator output shaft should be changed. In the case of actuators with a one-phase motor, this can be done by simply interchanging the lead-in wires of terminals U2 and Z2 on the terminal board of the actuator.

In the actuators with a three-phase motor, any two wires connected to terminals U, V and W should be interchanged on the actuator terminal board. Then, repeat the check to make sure that the actuator has been correctly connected, attach it to the valve and adjust, according to the Operating Instructions, Chapter "Adjustment of the Actuator". This adjustment can be best accomplished under manual control, the opening and closing operations of the microswitches being checked by means of a lamp or another suitable low-voltage tester up to 24 V.

Caution!

- 1) When adjusting, repairing or maintaining the actuators, safety precautions should be taken to prevent them from being inadvertently connected to the mains and thus to avert accidents that might be caused by electric current or gear rotation.
- 2) When reversing the actuators with a one-phase motor, care should be taken to ensure that, even for an instant, there is no phase voltage applied to the two outlets of the starting capacitor since, otherwise, the capacitor might discharge via contacts of the torque-limit switches and thus make them stuck.
- 3) When the thermal protection built in the electric motor (except for 120 W motors) fails to operate it is essential to consider that, as long as the supply voltage is present at the motor terminals, the actuator will automatically start after cooling down of the thermal protection.

At the end of the adjusting procedure, subject the actuator to a functional check by means of the control circuit, making sure particularly that the actuator starts correctly and is not “alive” after tripping of the respective microswitch. If this is not the case, the actuator should be immediately disconnected from the mains to avoid a damage to the electric motor and to find out the failure.

ATTENDANCE AND MAINTENANCE

Both electrical remote control and manual local control of the actuators at the site of installation are provided. For manual control, the handwheel of the actuator can be used, no change-over switch being required. This control mode can be safely used by the operator even during operation of the electric motor.

Maintenance attention to the actuators involves only replacing some faulty parts and adjusting the electromagnetic brake of the electric motor using this brake.

The brake should be readjusted after 0.5×10^5 switching operations, the air gap between the armature and the electromagnet core being set to a value of 0.6 to 0.8 mm. Adjustment can be carried out by means of nuts on the brake pull rod. The nut nearer to the electric motor is used for adjusting the required air gap, whilst the other nut serves for locking. After adjustment, check the correct function of the brake and secure the nut in position by a drop of varnish. Grease filling is stable for the whole service life of electric actuator which is at least 6 years. If the actuator is capable of operating even after 6 years of operation old grease should be removed from the power unit to pack it with fresh grease.

The connection screws between the valve and the actuator should be retightened crosswise after 6 months from the date of commissioning of the actuator at the latest and then at least yearly.

Table 1 – MODACT MOK (Control) electric actuators
– basic technical parameters

Type	Type number		Adjusting time [s/90°]	Tripping torque [Nm]	Electric motor					Weight [kg]	
	basic 1 2 3 4 5	complem. 6 7 8 9			Type	Output [W]	Speed [1.min ⁻¹]	Voltage [V]	Current [A]		
MOK 63	52 325	x x 1 x	10	16 – 32	FCJ2B52D	15	2780	1 x 230	0,37	7,4	
		x x 2 x	20			15	2780	1 x 230	0,37	7,4	
		x x 3 x	40			15	2780	1 x 230	0,37	7,4	
		x x 4 x	80	25 – 45	FCT2B54D	4	1270	1 x 230	0,25	7,4	
		x x 5 x	10	16 – 32	FT2B52D	15	2680	3 x 400	0,10	7,4	
		x x 6 x	20			15	2680	3 x 400	0,10	7,4	
		x x 7 x	40			15	2680	3 x 400	0,10	7,4	
		x x C x	40			15	2780	1x230	0,37	7,4	
MOK 125	52 326	x x 1 x	10	63 – 125	FCJ4C52N	60	2770	1 x 230	0,53	12,7	
		x x 2 x	20			60	2770	1 x 230	0,53	12,7	
		x x A x	20			60	2770	1x230	0,53	12,7	
		x x 3 x	40	63 – 125	FCT4C54N	20	1350	1 x 230	0,4	12,3	
		x x 4 x	80			20	1350	1 x 230	0,4	12,3	
		x x 5 x	10		FT4C52NA	90	2770	3 x 400	0,34	12,7	
		x x 6 x	20			90	2770	3 x 400	0,34	12,7	
		x x 7 x	40		EAMR56N04A	20	1440	3 x 400	0,20	12,7	
		x x 8 x	80			20	1440	3 x 400	0,20	12,7	
		MOK 250	52 327		x x 2 x	20	125 – 250	FCJ4C52N	60	2770	1 x 230
x x 3 x	40				60	2770			1 x 230	0,53	21
x x A x	40			60	2770	1 x 230			0,53	21	
x x 4 x	80			125 – 250	FCT4C54N	20	1350	1 x 230	0,4	20,5	
x x 5 x	160					20	1350	1 x 230	0,4	20,5	
x x 6 x	20				FT4C52NA	90	2770	3 x 400	0,34	21	
x x 7 x	40					90	2770	3 x 400	0,34	21	
x x 8 x	80				EAMR56N04A	20	1440	3 x 400	0,20	21	
x x 9 x	160					20	1440	3 x 400	0,20	21	
MOK 500	52 328				x x 2 x	20	250 – 500	1 PK 7060-4AB	120	1350	3 x 400
		x x 3 x	40		120	1350			3 x 400	0,42	26
		x x 4 x	80	120	1350	3 x 400			0,42	26,3	
		x x C x	40	EAMRB63L02	90	2780		1 x 230	0,90	27	
MOK 1000	52 329	x x 3 x	40	500 – 1000	1 PK 7060-4AB	120	1350	3 x 400	0,42	45	
		x x 4 x	80			120	1350	3 x 400	0,42	43	
		x x 5 x	160			120	1350	3 x 400	0,42	43,3	
		x x C x	80		EAMRB63L02	90	2780	1 x 230	0,90	45	

*) Design variants with a greater tripping torque up to 80 Nm can be used at an ambient temperature of -20 °C to +55 °C.

In the type number, the following numeric symbol should be inserted:

6th position determine the possibility of using the position transmitter and electrical connection

	terminal	connector
design with resistance transmitter	6 x x x	A x x x
design with current transmitter 4 -20 mA without built-in power supply	7 x x x	B x x x
design without position transmitter	8 x x x	C x x x
design with current transmitter 4 -20 mA with built-in power supply	9 x x x	D x x x

7th position: 0 – design without built-in position controller and without BMO (*block of local control*)

1 – design with built-in position controller without BMO – **MODACT MOK Control**

2 – design without built-in position controller with BMO

3 – design with position controller and BMO – **MODACT MOK Control**

8th position: Insert a number or letter, according to Table 1.

9th position: Insert a number or letter, according to Table 2.

Table 2 – MODACT MOK (Control)

– way of mechanical connection (specification of 9th place of type number)

Flange size	Connection	Square size s [mm]	Square position	Marking on the 9 th place of type number
Type Number 52 325				
F05	keyway	∅ 22		0
F05	square	14	basic	1
F04	keyway	∅ 18		2
F04	square	11	basic	3
F05		14	positioned at a 45°	4
F04		11	positioned at a 45°	5
F04		12	basic	6
F04		12	positioned at a 45°	7
F05		16	basic	8
F05		16	positioned at a 45°	9
Type Number 52 326				
F07	keyway	∅ 28		0
F07	square	17	basic	1
F05	keyway	∅ 22		2
F05	square	14	basic	3
F07		17	positioned at a 45°	4
F05		14	positioned at a 45°	5
F05		16	basic	6
F05		16	positioned at a 45°	7
F07		19	basic	8
F07		19	positioned at a 45°	9
Type Number 52 327				
F10	keyway	∅ 42		0
F10	square	22	basic	1
F07	keyway	∅ 28		2
F07	square	17	basic	3
F10		22	positioned at a 45°	4
F07		17	positioned at a 45°	5
F07		19	basic	6
F07		19	positioned at a 45°	7
F10		24	basic	8
F10		24	positioned at a 45°	9
F10		27	basic	A
F10		27	positioned at a 45°	B
Type Number 52 328				
F12	keyway	∅ 50		0
F12	square	27	basic	1
F10	keyway	∅ 42		2
F10	square	22	basic	3
F12		27	positioned at a 45°	4
F10		22	positioned at a 45°	5
F10		24	basic	6
F10		24	positioned at a 45°	7
F10		27	basic	8
F10		27	positioned at a 45°	9
F12		32	basic	A
F12		32	positioned at a 45°	B
Type Number 52 329				
F12	keyway	∅ 50		0
F12	square	27	basic	1
F12		27	positioned at a 45°	4
F12		32	basic	5
F12		32	positioned at a 45°	6

Actuator output shaft position (when viewing towards the local position indicator). The handwheel tallies with the CLOSED position	Keyway connection	Square
		basic position (to DIN 3337)

Other connection of the actuator upon special request.

Addition to table 2 – MODACT MOK electric actuators with lever adapter

– mechanical connection (designation of the 9th place of the type number)

Flange size	Connection	Square size s [mm]	Square position	Marking of the 9th position in the type number	Structural design of output
Type number 52 325					
F05	keyway	∅ 22		0	collar
F05	square	14	basic	1	exchangeable inserts
F04	keyway	∅ 18		2	
F04	square	11	basic	3	
F05		14	positioned at a 45°	4	
F04		11	positioned at a 45°	5	
F04		12	basic	6	
F04		12	ppositioned at a 45°	7	
F05		16	basic	8	
F05		16	positioned at a 45°	9	
Actuator with lever adapter				W	
Type number 52 326					
F07	keyway	∅ 28		0	not available
F07	square	17	basic	1	exchangeable inserts
F05	keyway	∅ 22		2	
F05	square	14	basic	3	
F07		17	positioned at a 45°	4	
F05		14	positioned at a 45°	5	
F05		16	basic	6	
F05		16	positioned at a 45°	7	
F07		19	basic	8	
F07		19	positioned at a 45°	9	
Actuator with lever adapter				W	

Dimensional sketch of MODACT MOK electric actuator with lever adapter

Lever

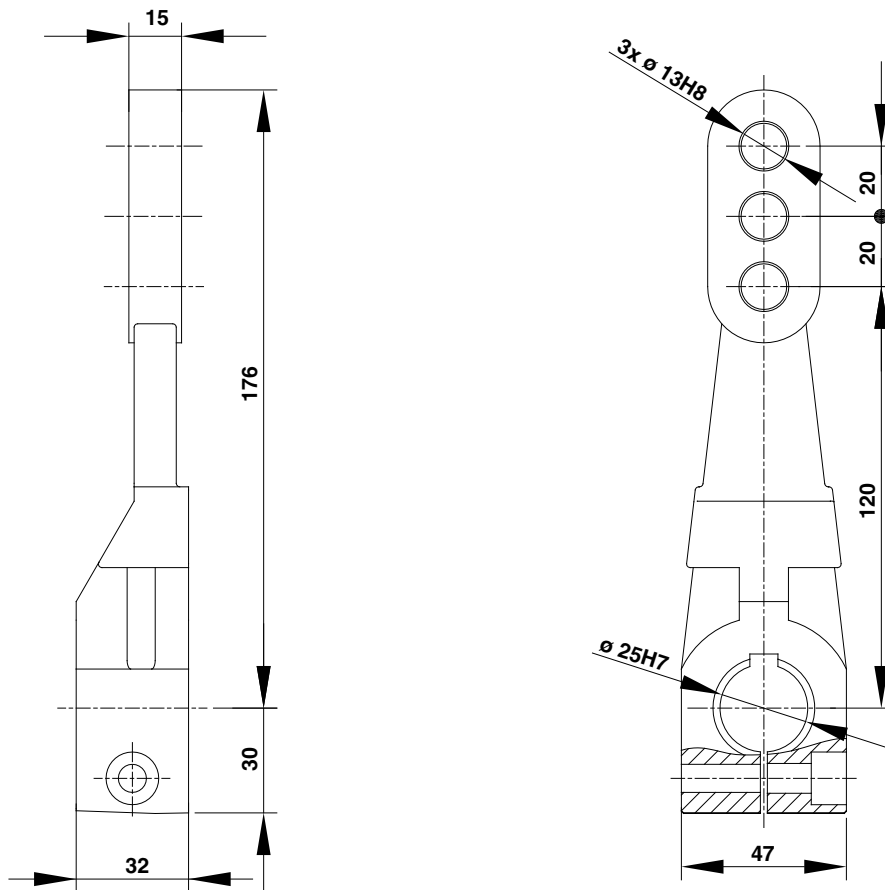

Lever adapter with Type No. 52325 actuator

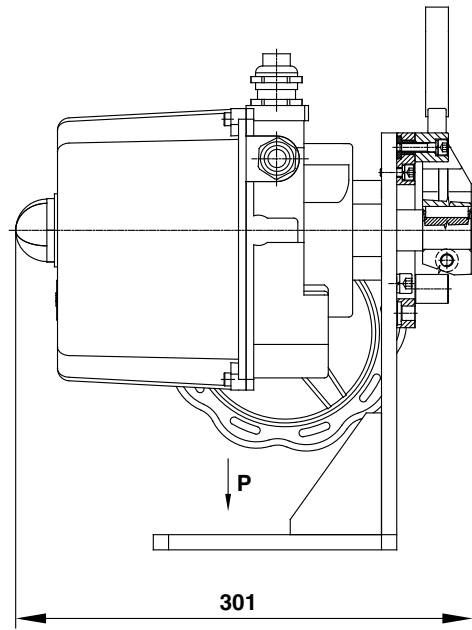
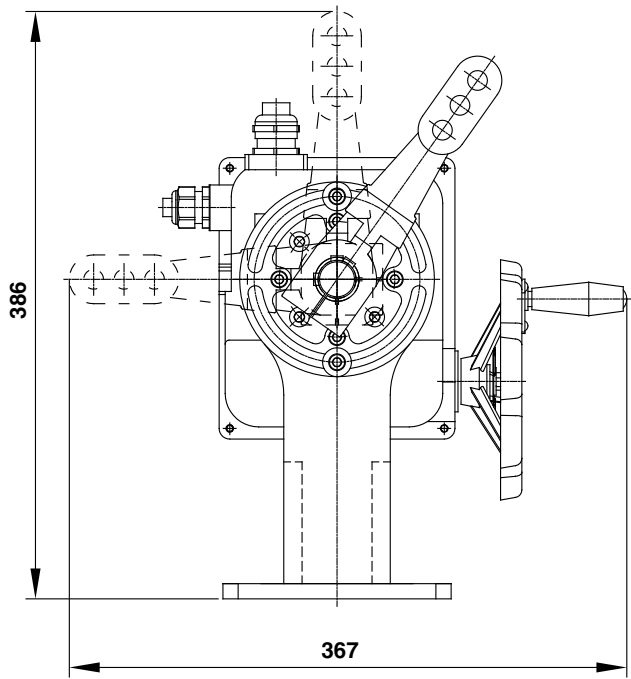

→ P
M2:1
(view of the base plate)

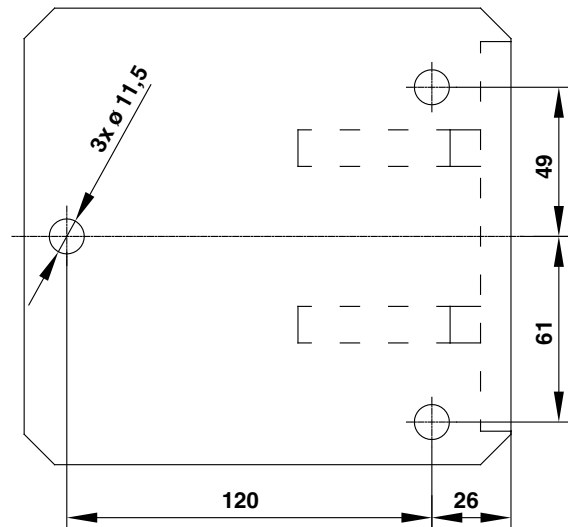

Lever adapter with **Type No. 52326** actuator

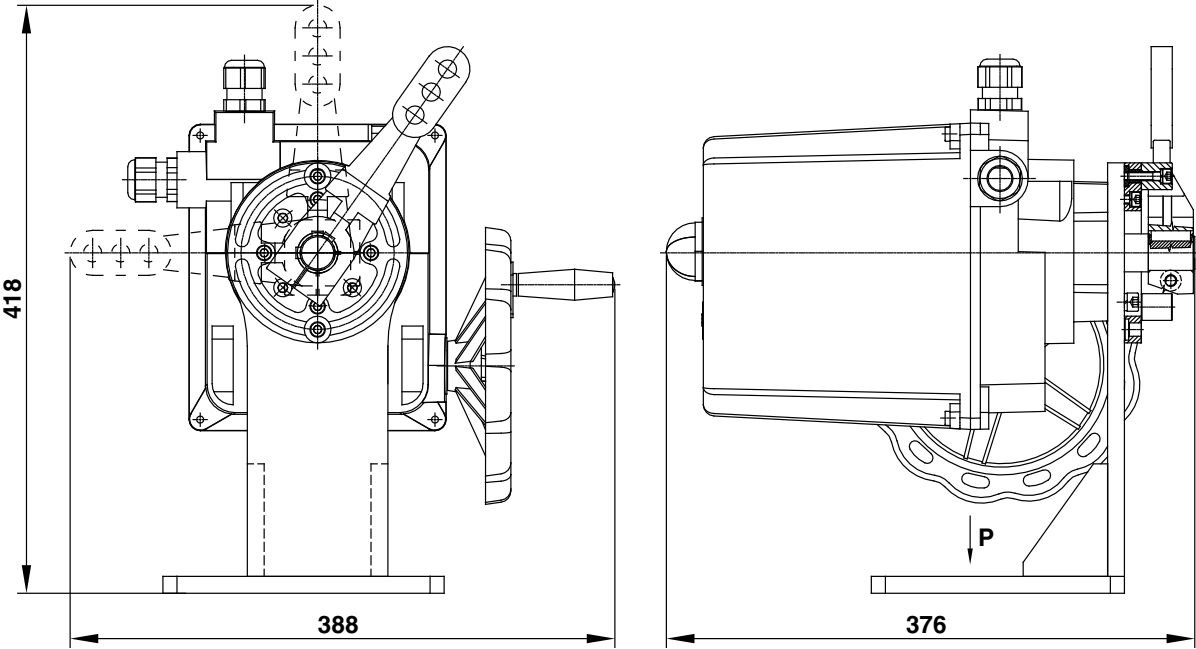

→ P
 M2:1
 (view of the base plate)

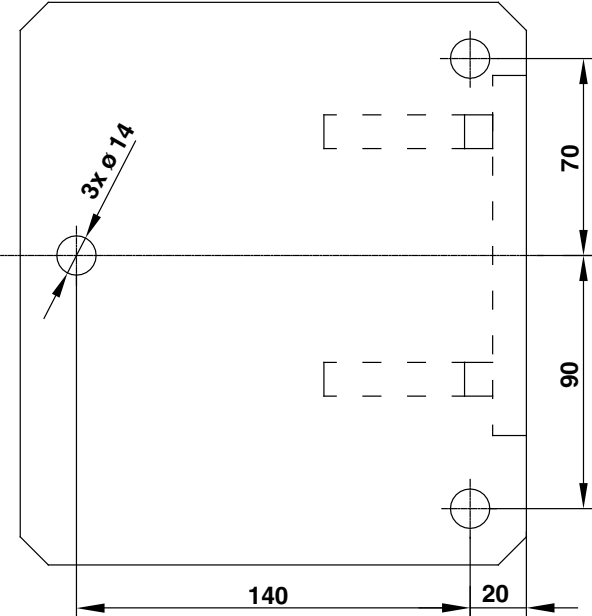

Note: Other dimensions are listed in the dimension table.

Dimensional sketch of MODACT MOK electric actuators

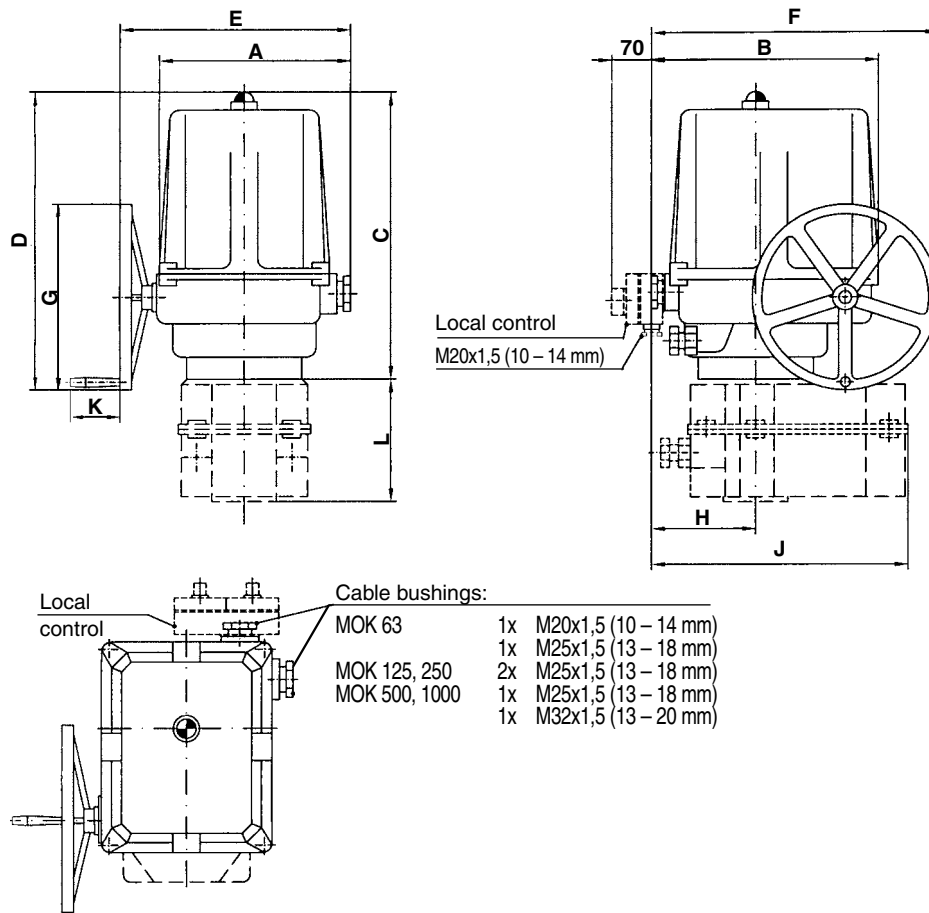

Type	A	B	C	D	E	F	G	H	J	K	L	Flange
MOK 63	173	203	247	244	213	245	160	98	-	73	-	F 05, F 04, F 07*
MOK 125	204	237	325	347	252	290	200	111	-	73	-	F 07, F 05, F 10*
MOK 250	204	237	325	347	252	290	200	111	263	73	128	F 10, F 07
MOK 500	250	290	386	398	325	362	250	128	-	73	-	F 12, F 10
MOK 1000	250	290	386	398	325	362	250	128	323	73	155	F 12

*) on request

Note: Connecting of actuators with connector – on special request.

Connection dimensions of MODACT MOK actuators

– for valves and control devices with spindles that are provided with a tight-fit keyway

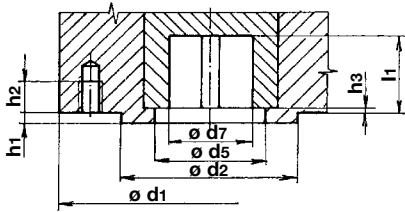

Position of the keyway, according to ISO 5211 and DIN 3337
(The groove is in the CLOSE position whereas the OPEN position is on the left side when viewing the local position indicator)

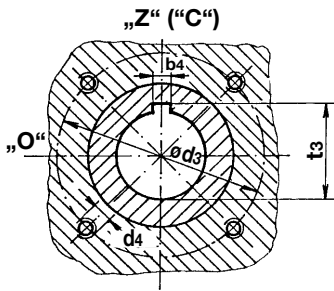

Flange	$\varnothing d_1$	$\varnothing d_2$ f8	$\varnothing d_3$	d_4	$\varnothing d_7$ H9	h_3 max	h_2 min	h_1 max	l_1 min	b_4 Js9	t_3 ^{+0,4} _{+0,2}	$\varnothing d_5$
F04	65	30	42	M6	18	3	12	3	26	6	20,5	25
F05	65	35	50	M6	22	3	12	3	30	6	24,5	28
F07	90	55	70	M8	28	3	13	3	35	8	30,9	40
F10	125	70	102	M10	42	3	16	3	45	12	45,1	50
F12	150	85	125	M12	50	3	20	3	53	14	53,5	70

Note: The CLOSE position "Z" ("C") of the keyway is identical to the "Z" "C" position on the local position indicator.
Dimension d_1 is determined by a larger flange used by the actuator.

– for valves and control devices with spindles that are provided with a square hole

Position of the square hole in the end position of the actuator. The OPEN position is on the left of the CLOSE position, when viewing the local position indicator.

The square hole corresponds to DIN 79. The connecting dimensions comply with DIN 3337 or ISO 5211

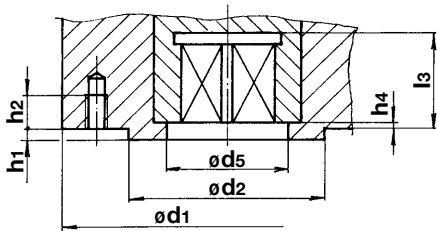

Flange	$\varnothing d_1$	$\varnothing d_2$ f8	$\varnothing d_3$	d_4	h_4		h_2 min	h_1 max	l_3 min	s H11	e min	$\varnothing d_5$
					max	min						
F04	55	30	42	M6	1,5	0,5	12	3	15,1 16,1	11 12	14,1 16,1	25
F05	65	35	50	M6	3	0,5	12	3	19,1 22,1	14 16	18,1 21,2	28
F07	90	55	70	M8	3	0,5	13	3	23,1 26,1	17 19	22,2 25,2	40
F10	125	70	102	M10	3	1	16	3	30,1 33,1 37,1	22 24 27	28,2 32,2 36,2	50
F12	150	85	125	M12	3	1	20	3	37,1 44,1	27 32	36,2 42,2	70

Note: The CLOSE position "Z" ("C") of the square hole for the spindle is identical to the "Z" "C" position on the local position indicator.
Dimension d_1 is determined by a larger flange used by the actuator.

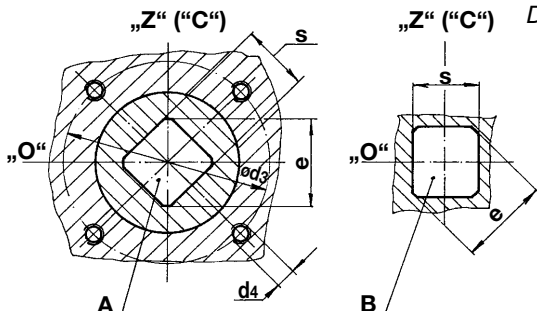

A – Square-end joint in the basic position

B – Square-end joint positioned at an angle of 45°

Wiring diagrams of MODACT MOK electric actuators

Legend:

- | | |
|---|--|
| <p>SQ1 (MO) – OPEN torque-limit switch
 SQ2 (MZ) – CLOSE torque-limit switch
 SQ3 (PO) – OPEN position-limit switch
 SQ4 (PZ) – CLOSE position-limit switch
 SQ5 (SO) – OPEN signalling switch
 SQ6 (SZ) – CLOSE signalling switch
 EH – Anti-condensation heater
 (MOK 63 12 kΩ, other 6.8 kΩ)
 SA1 – LOCAL/REMOTE switch
 SA2 – OPEN/CLOSE switch
 C – Motor capacitor
 M1~ – One-phase motor</p> | <p>M3~ – Three-phase motor
 YB – Electromagnetic brake
 BQ1 – Resistance transmitter 1x 100 Ω
 CPT 1 – Current position transmitter CPT 1Az
 DCPT – Current position transmitter DCPT
 DCPZ – Power supply of current transmitter DCPT
 ZP2.RE – Microcomputer position regulator
 KO – Directional relay for the OPEN direction
 KZ – Directional relay for the CLOSE position
 F – Thermal safety
 F(φ) – Thermal relay
 R1, R2 – 2x resistance protection 10 Ω
 for single-phase motors</p> |
|---|--|

Positions of the switches: M – Local; D – Remote; O, OTV – Open; Z, ZAV – Close

Warning:

In the actuators with a single-phase electric motor, the control phase must not be connected to both outlets of the capacitor at the same time, not even for a moment; otherwise, there is a danger of the end-limit micro-switches being damaged.

Wiring diagrams of MODACT MOK 63 electric actuators

– with the resistance transmitter

– with a one-phase motor

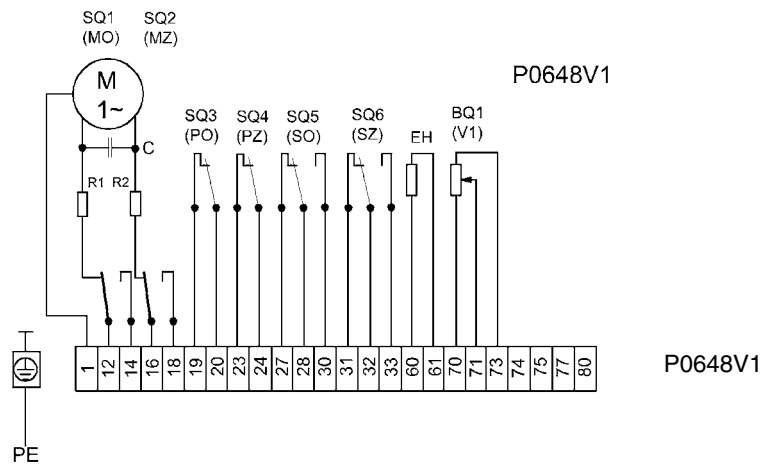

– with a one-phase motor and local control

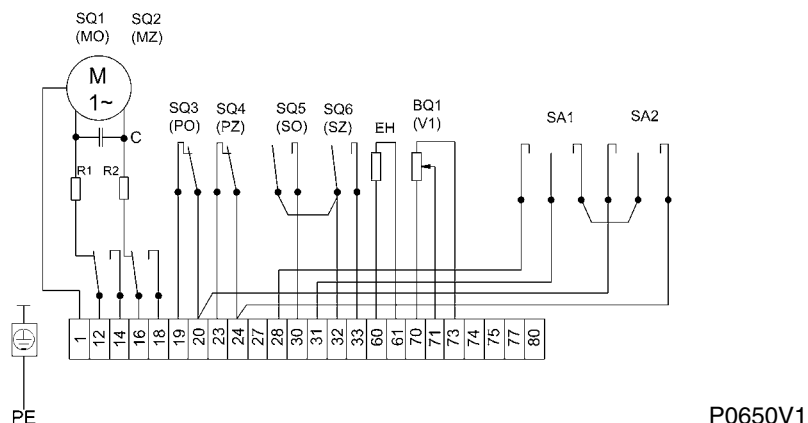

Wiring diagram of **MODACT MOK 63** electric actuators – with a one-phase motor

– with the current transmitter without built-in power supply or without transmitter

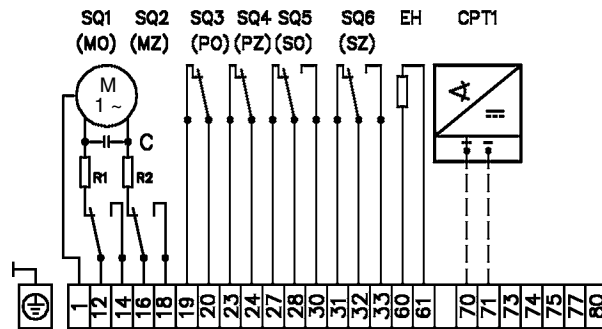

P-0693

– with the current transmitter with built-in power supply

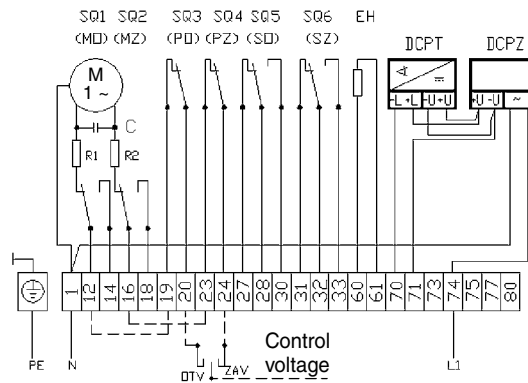

P-0694-E

– with the current transmitter without built-in power supply or without transmitter, with local control

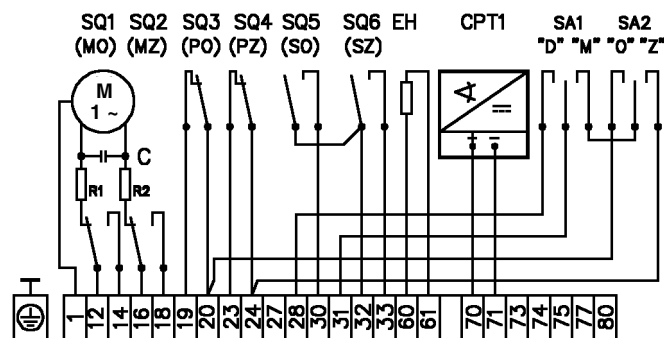

P-0750

– with the current transmitter with built-in power supply, with local control

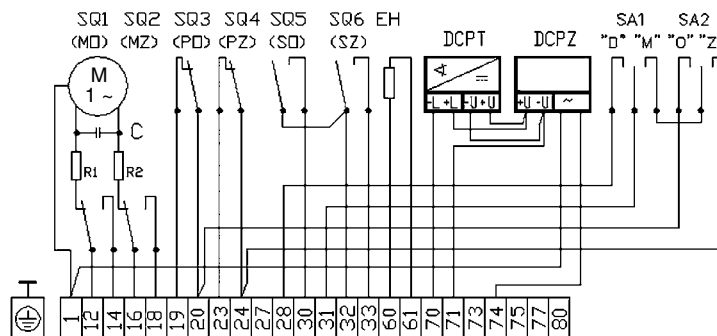

P-0751-E

Wiring diagram of **MODACT MOK 63** electric actuators – with three-phase electric motor

– with current transmitter and built-in power supply, with local control or without local control

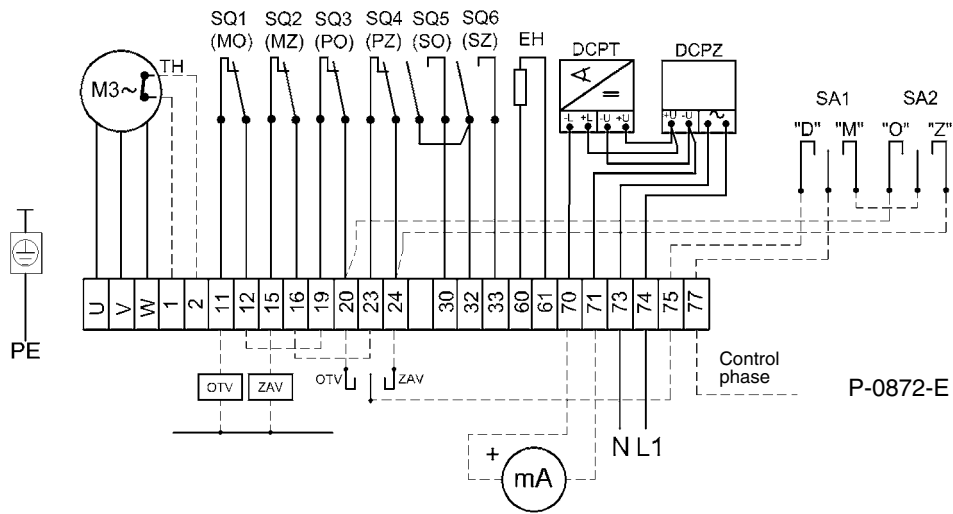

– with the resistance transmitter, without local control or with local control

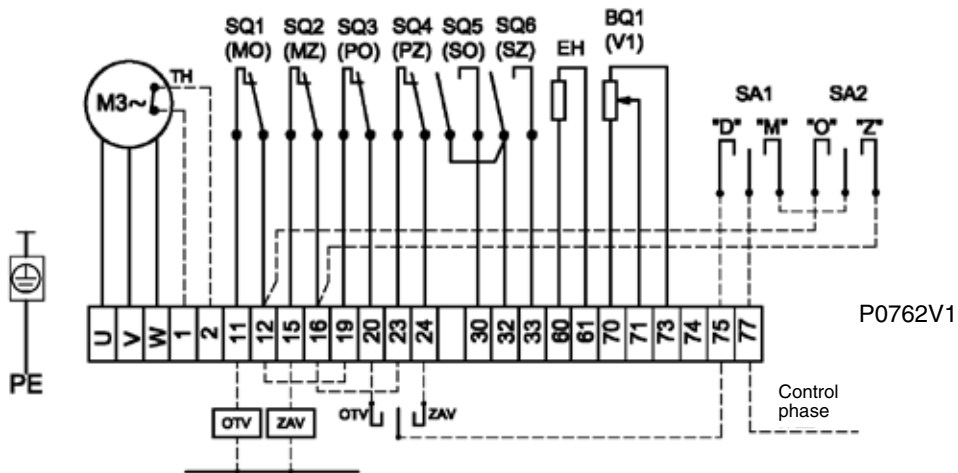

– with current transmitter without built-in power supply or without transmitter,
with local control or without local control

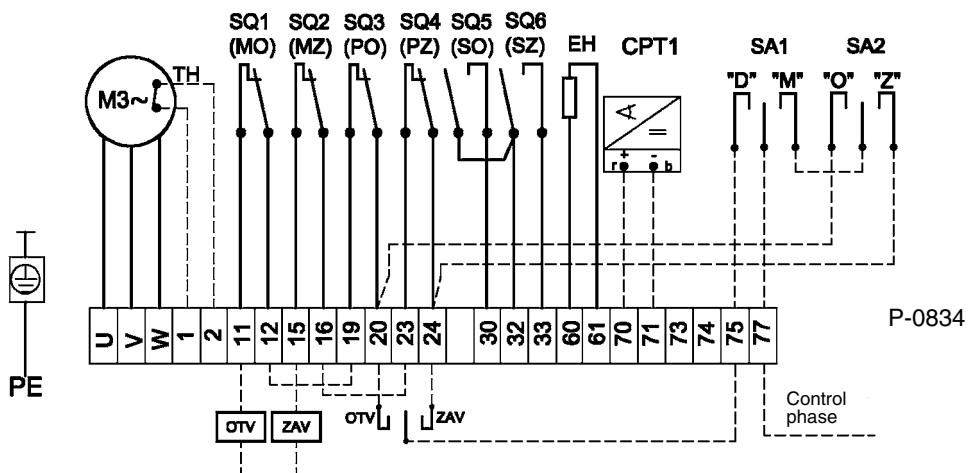

Wiring diagrams of **MODACT MOK 125 – 1000** electric actuators
 – with a one-phase motor

– with the resistance transmitter

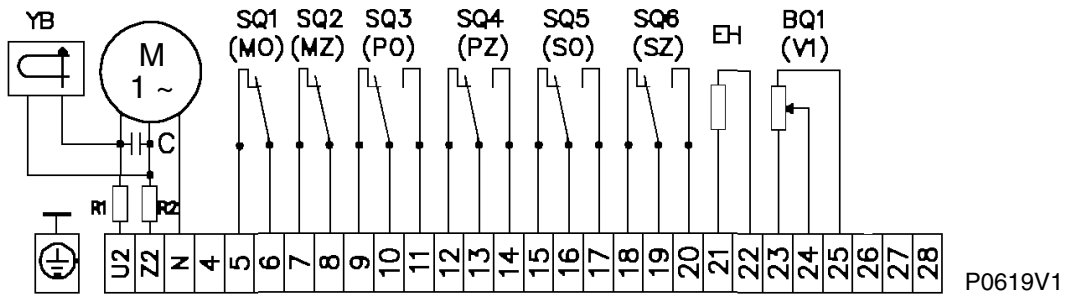

– with the resistance transmitter and local control

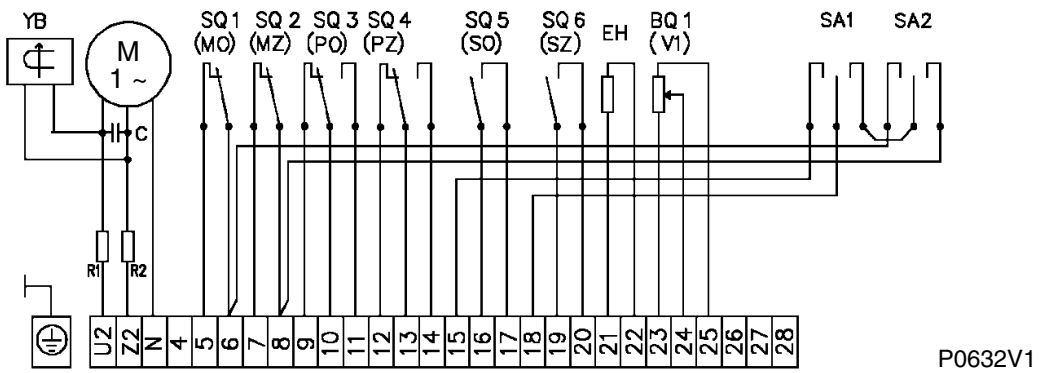

– with a three-phase motor

– with the resistance transmitter

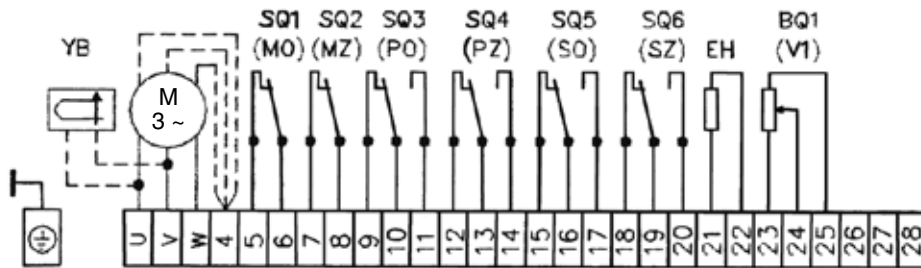

– with the resistance transmitter and local control

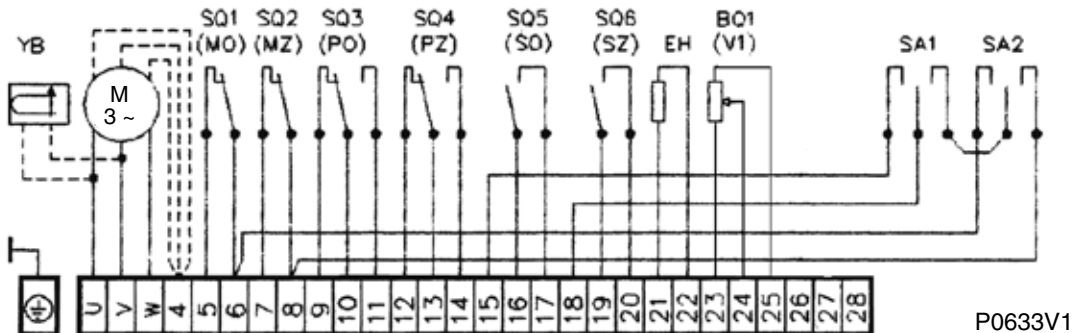

Wiring diagrams of **MODACT MOK 125 – 1000** electric actuators – with a one-phase motor

– with the current transmitter without built-in power supply or without transmitter

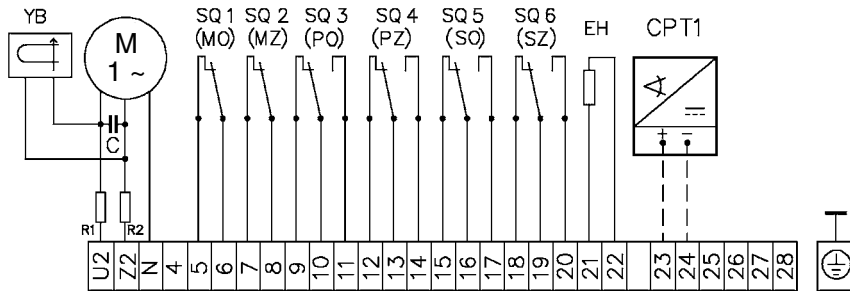

P-0695

– with the current transmitter with built-in power supply

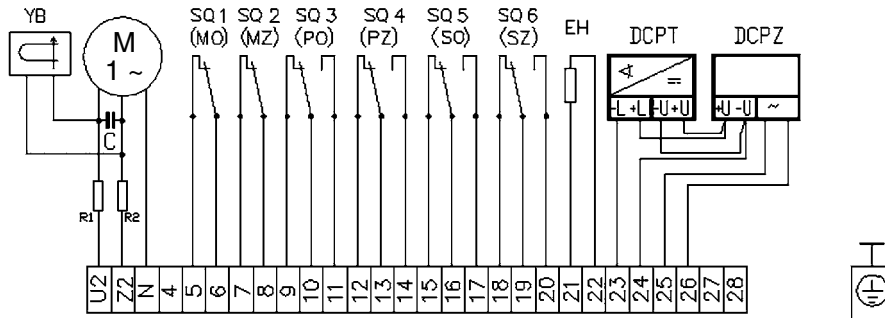

P-0696-E

– with the current transmitter without built-in power supply or without transmitter, with local control

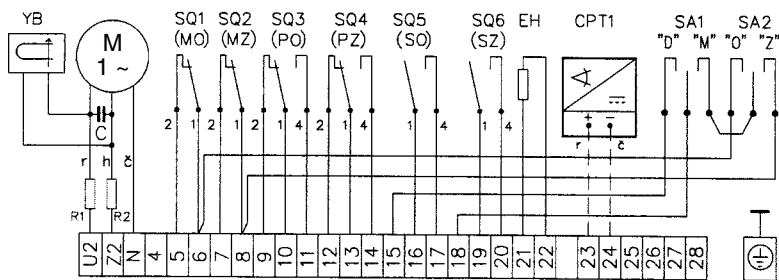

P-0747

– with the current transmitter with built-in power supply, with local control

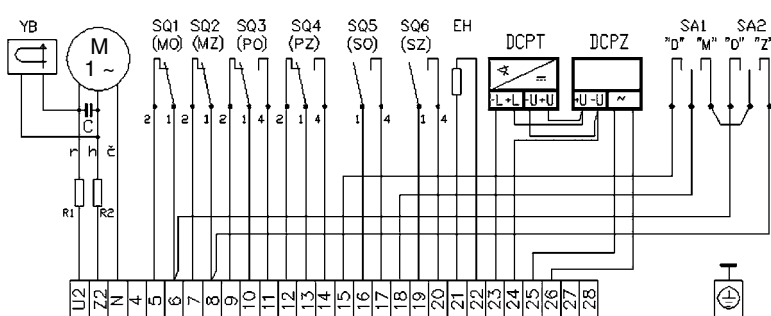

P-0748-E

Wiring diagrams of MODACT MOK 125 – 1000 electric actuators – with three-phase electric motor

– with the current transmitter without built-in power supply or without transmitter

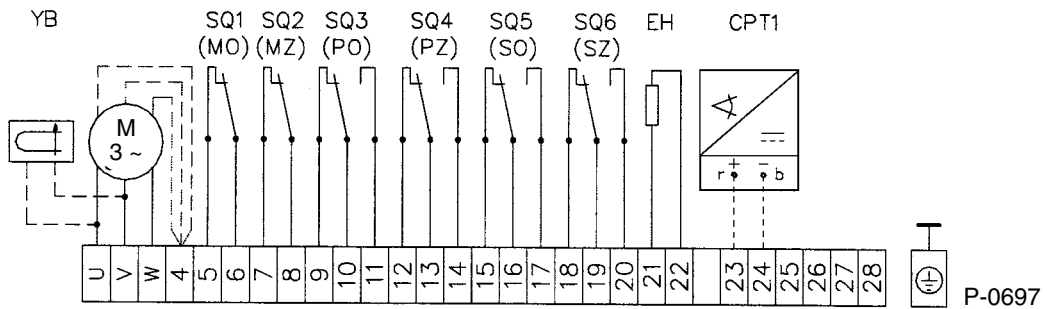

– with the current transmitter with built-in power supply

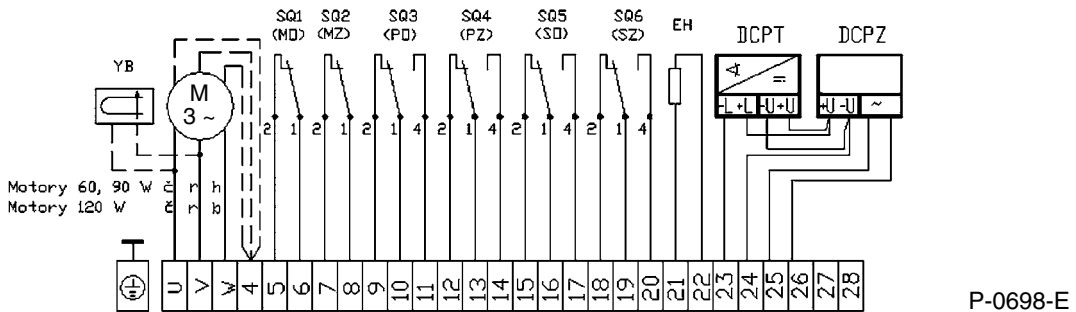

– with the current transmitter without built-in power supply or without transmitter, with local control

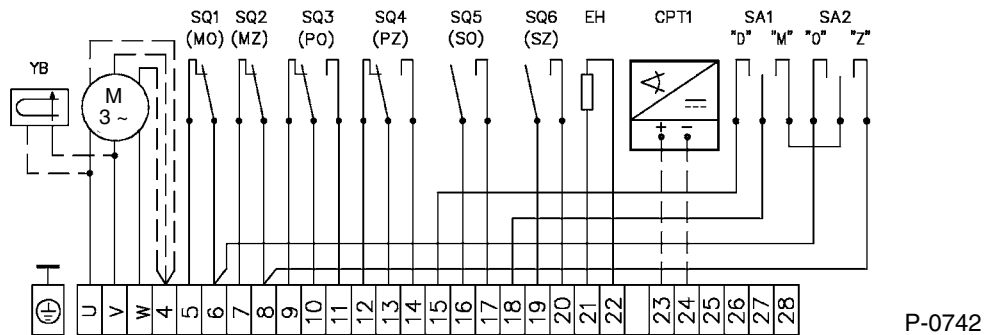

– with the current transmitter with built-in power supply, with local control

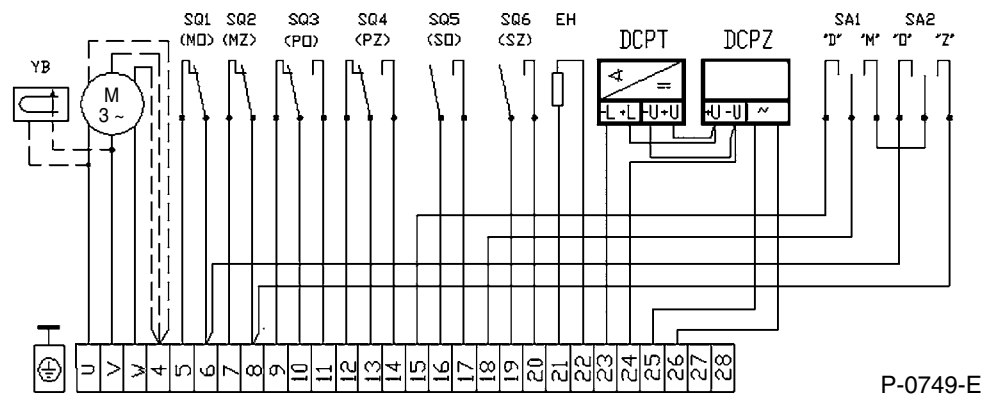

Wiring diagram of **MODACT MOK 63 Control** electric actuators
 – with the one-phase motor and position regulator

P-0785-EZ

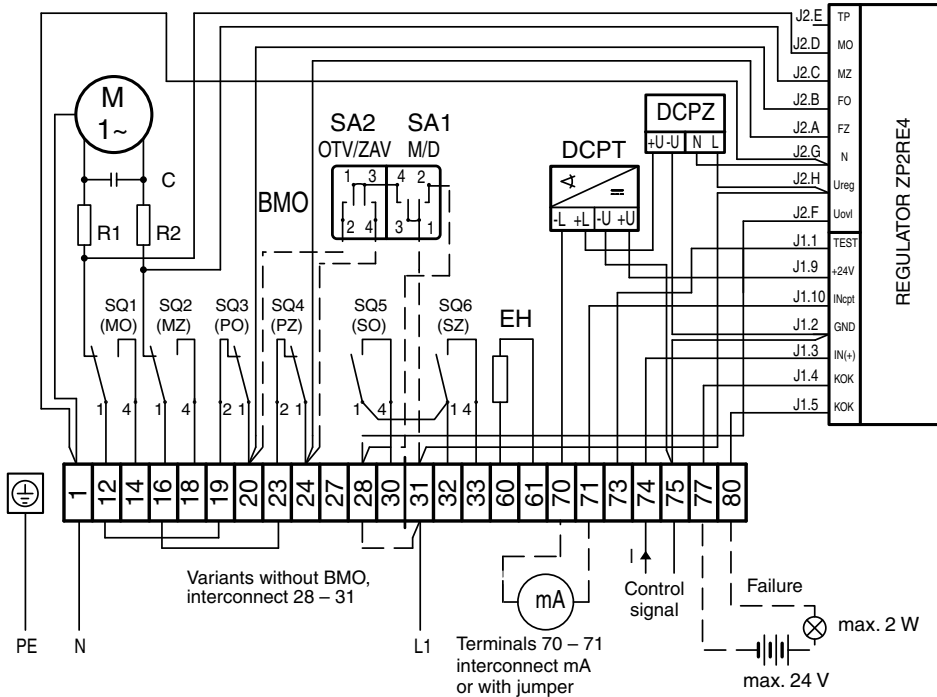

Wiring diagram of **MODACT MOK 125 – 1000 Control** electric actuators
 – with the one-phase motor and position regulator

P-0780-EZ

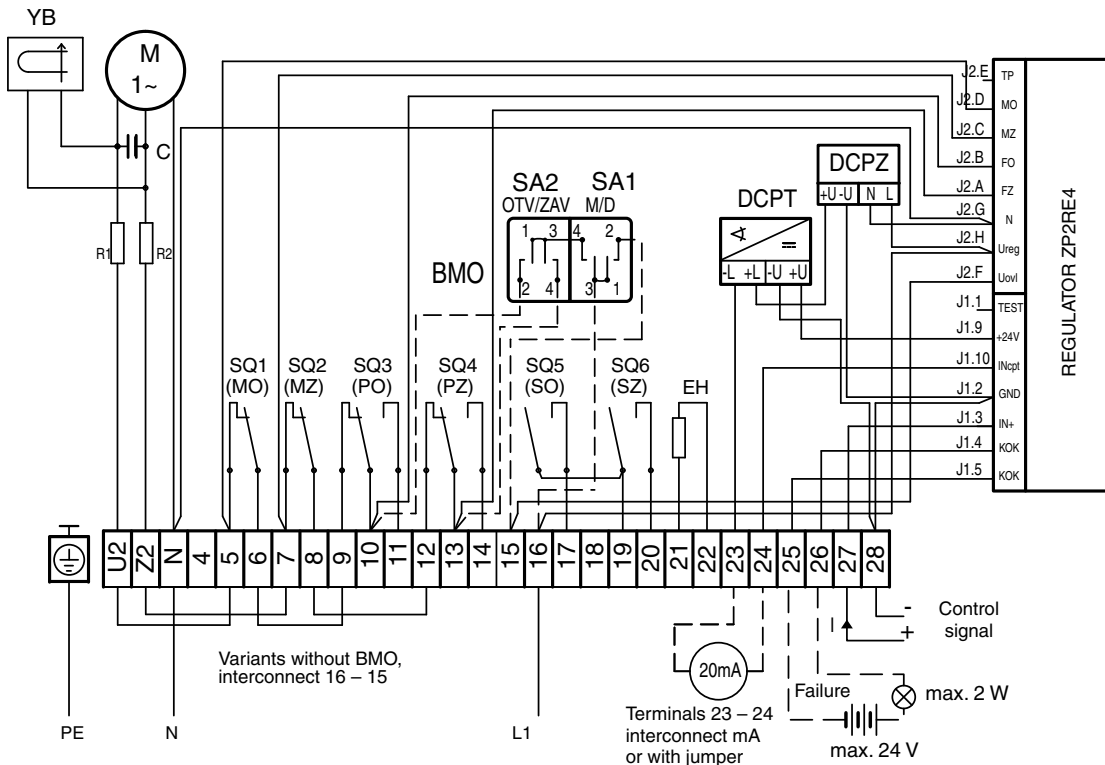

Wiring diagram of MODACT MOK 63 Control electric actuators

– with the three-phase motor and position regulator

P-0920-EZ

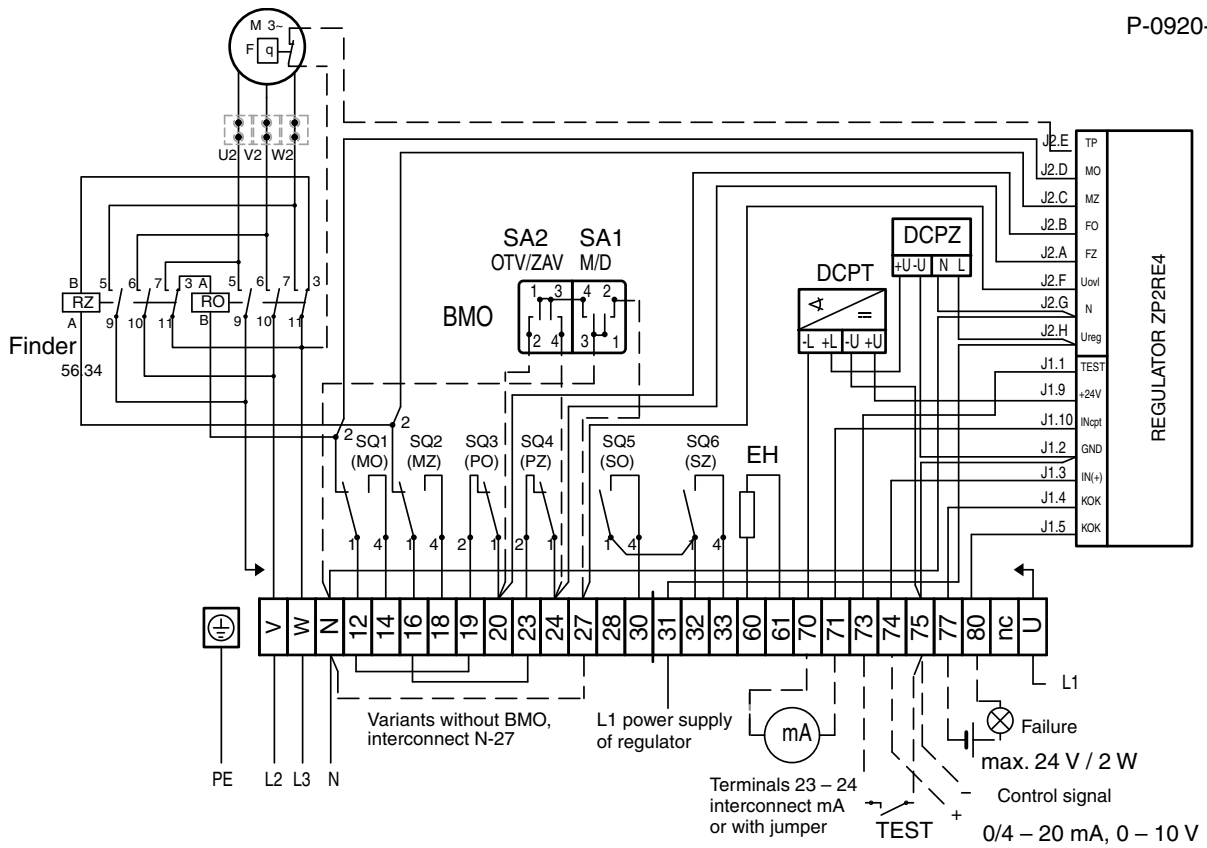

Wiring diagram of **MODACT MOK 125 – 1000 Control** electric actuators – with the three-phase motor and position regulator

P-0779-EZ

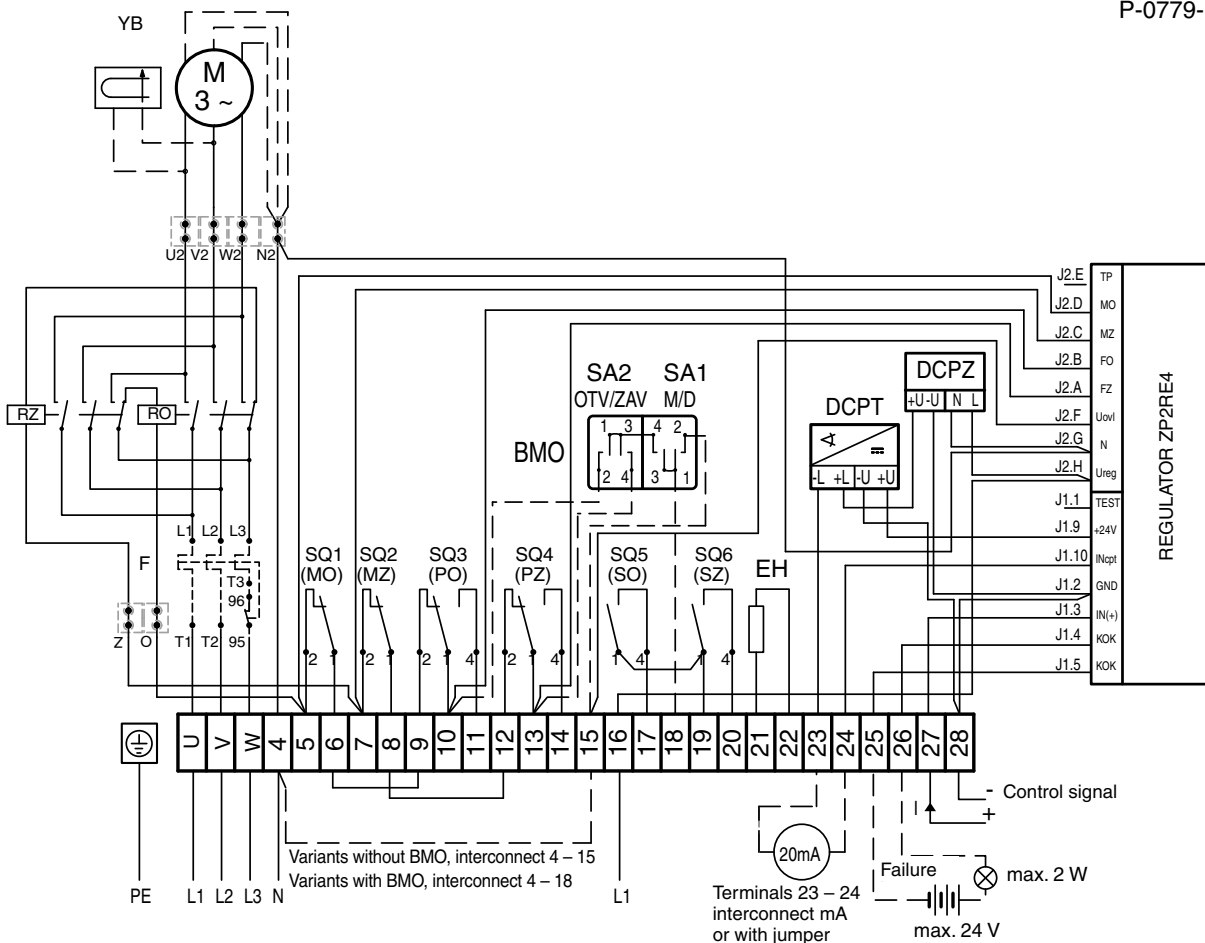

52 325, 52 326 and 52 327 – Finder relay 56, 34
52 328 and 52 329 – Schrack RM735730 relay + thermal relay Lovato

Notes:

The feedback signal can be brought out provided that its galvanic separation from the input signal has been ensured.

The TEST signal can be activated by an external make contact. This signal need not be connected.

From the terminals 25 and 26 (for **MODACT MOK 125, 250, 500** and **1000**) or 77 and 80 (for **MODACT MOK 63**), a failure signal can be brought out. This signal is galvanically separated from the regulator circuits.

The maximum voltage which can be applied to these terminals, is 24 V.

In the design variant with the current transmitter, the user should provide for connection of the two-wire circuit of the current transmitter to the electric earth of the associated regulator, computer, etc. The connection should only be made at a single point in any section of the circuit outside the electric actuator. The voltage between electronics and the current transmitter case should not exceed 50 VDC.

Warning! In the ZP2.RE regulator, all circuits of the current transmitter are connected to the input signal circuits and the circuits connected to the regulator TEST terminal. The electric earth connection of these circuits should be made only at a single point of one of the three circuits, while other circuits should not be connected to the earth.

Analog signals should be transmitted via a screened conductor. At the signal source the screening should be connected to the common conductor.

Spare parts

Designation	Application
Microswitch DB1G - A1LC available from ZPA Pečky a.s.	MO, MZ, PO, PZ, SO, SZ
Packing 224648300	Packing between the control section cover and the power unit box for actuators, Type Nos 52 325
Packing 224648301	Packing between the control section cover and the power unit box for actuators, Type Nos 52 326, 52 327
Packing 224648302	Packing between the control section cover and the power unit box for actuators, Type Nos 52 328, 52 329

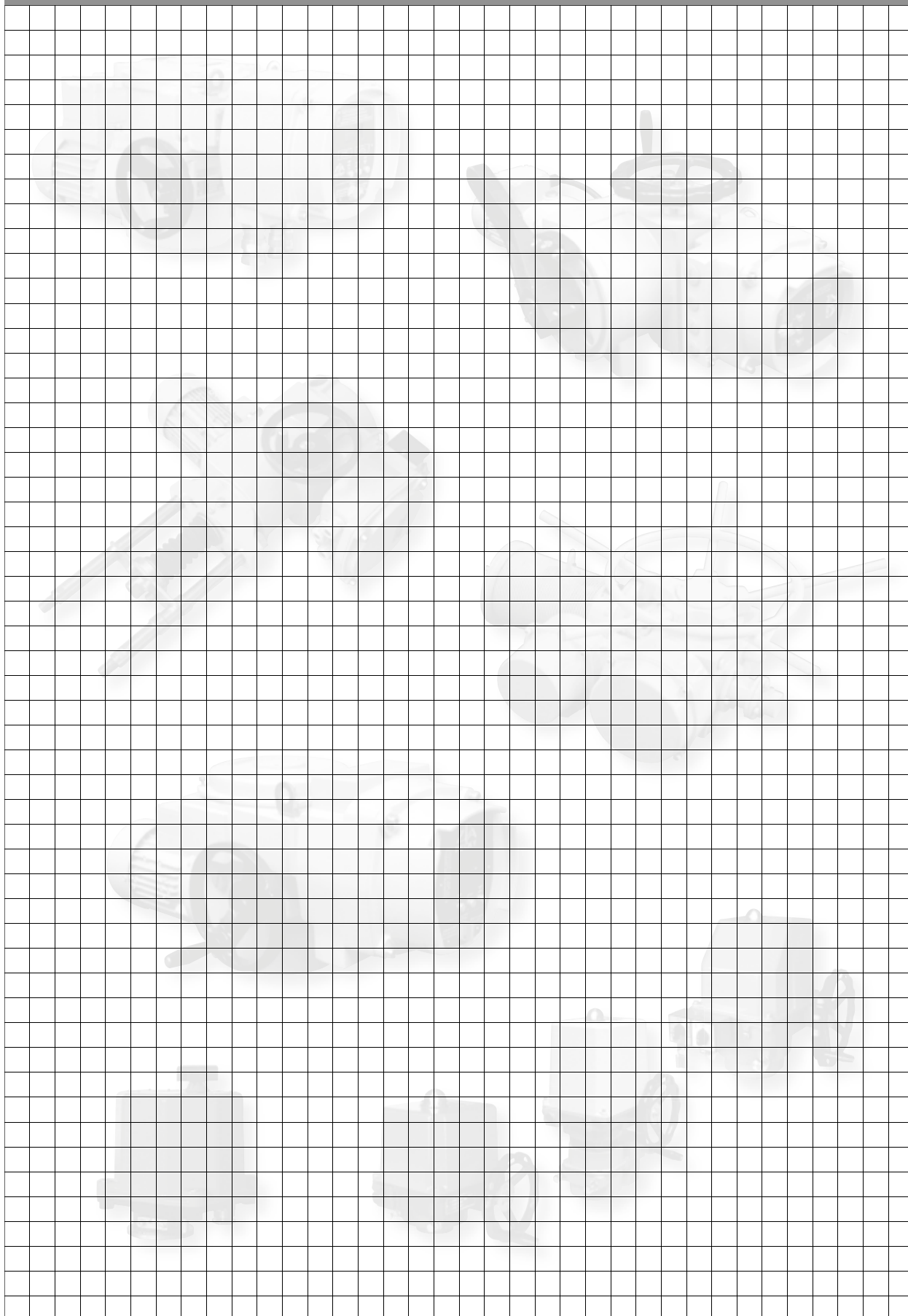

NOTE

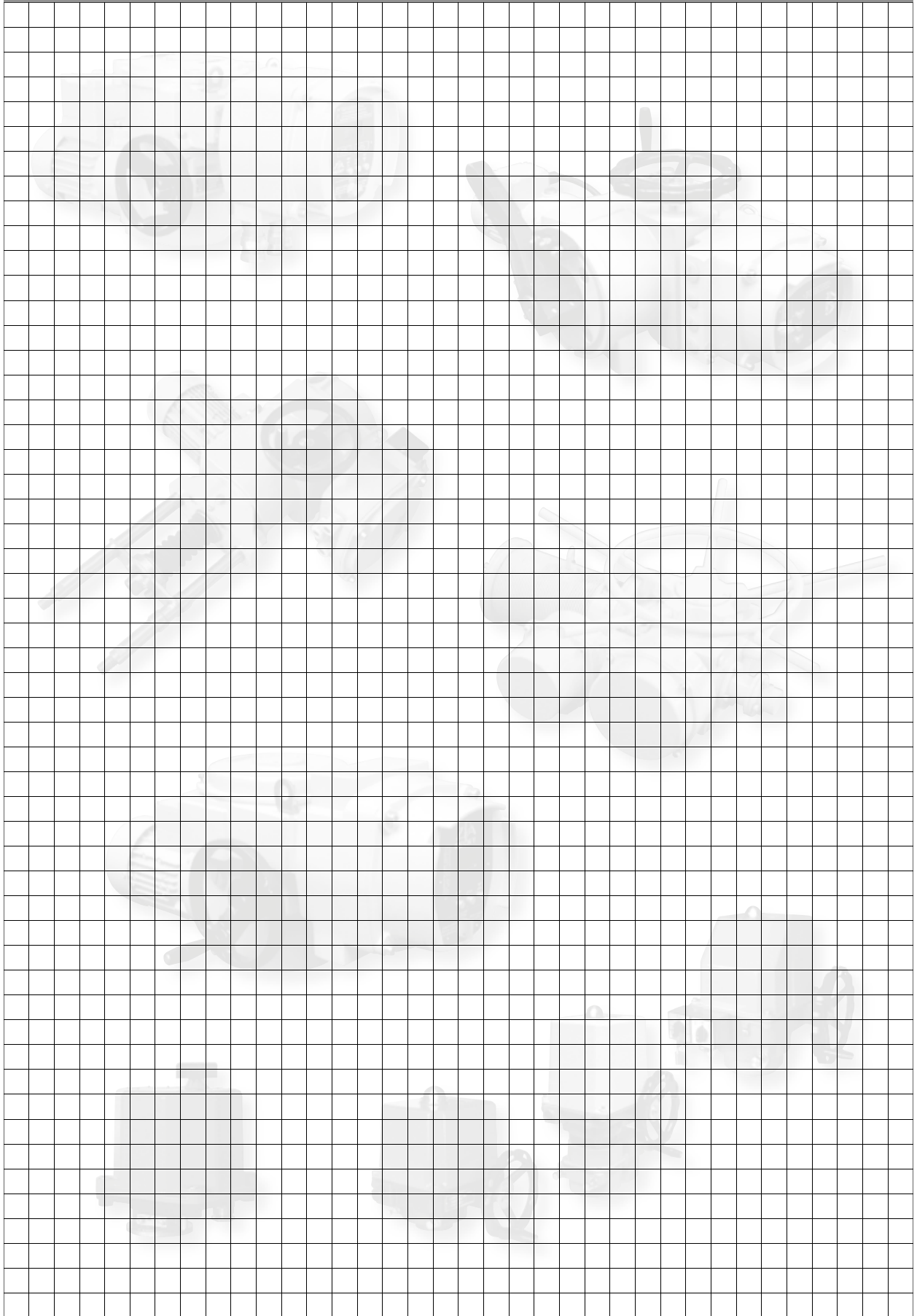



Development, production and services of electric actuators and switchboards.
Top-quality sheet-metal processing (TRUMPF equipment), powder paint shop.

SURVEY OF PRODUCED ACTUATORS

KP MINI, KP MIDI

Electric rotary (90°) actuators (up to 30 Nm)

MODACT MOK, MOKED, MOKP Ex, MOKPED Ex

Electric rotary (90°) actuators for ball valves and flaps

MODACT MOKA

Electric rotary (90°) actuators for nuclear power stations
application outside containment

MODACT MON, MOP, MONJ, MONED, MOPED, MONEDJ

Electric rotary multi-turn actuators

MODACT MO EEx, MOED EEx

Explosion proof electric multi-turn actuators

MODACT MOA

Electric multi-turn actuators for nuclear power stations
application outside containment

MODACT MOA OC

Electric multi-turn actuators for nuclear power stations
application inside containment

MODACT MPR Variant

Electric rotary (160°) lever actuators with a variable output speed

MODACT MPS, MPSP, MPSED, MPSPED

Electric rotary (160°) lever actuators with a constant output speed

MODACT MTN, MTP, MTNED, MTPED

Electric linear thrust actuators with a constant output speed

Deliveries of assembled actuator + valve (or MASTERGEAR gearbox) combinations

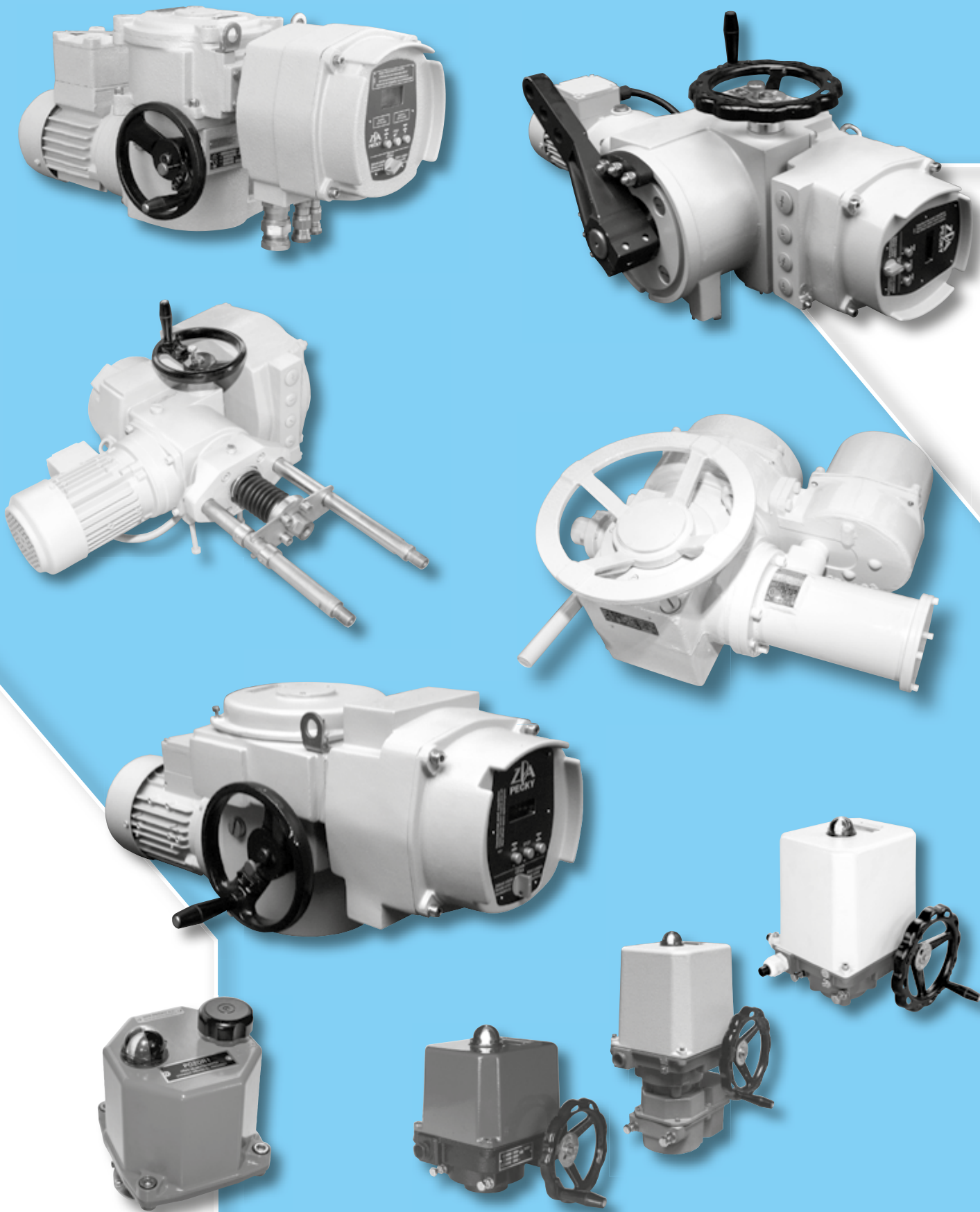

ZPA Pečky, a.s.
tř. 5. května 166
289 11 PEČKY, Czech Republic
www.zpa-pecky.cz

tel.: +420 321 785 141-9
fax: +420 321 785 165
+420 321 785 167
e-mail: zpa@zpa-pecky.cz