

**Electric Linear (Pull-rod)  
actuators**

**MODACT MTNED, MTPED**

**Type numbers 52 442, 52 443**

# CERTIFICATE **TÜV NORD**

Management system as per  
**EN ISO 9001 : 2008**

In accordance with TÜV NORD CERT procedures, it is hereby certified that

**ZPA Pečky, a.s.**  
Třída 5. května 166  
289 11 Pečky  
Czech Republic



applies a management system in line with the above standard for the following scope

**Development and production of electric actuators,  
switch boards and sheet metal working.**

Certificate Registration No. 04 100 950161  
Audit Report No. 624 362/300

Valid until 2012-09-24  
Initial certification 1995-03-01

Certification Body  
at TÜV NORD CERT GmbH

Praha, 2009-09-25

This certification was conducted in accordance with the TÜV NORD CERT auditing and certification procedures and is subject to regular surveillance audits.

TÜV NORD CERT GmbH

Langemarckstrasse 20

45141 Essen

[www.tuev-nord-cert.com](http://www.tuev-nord-cert.com)



TGA-ZM-07-06-00

## APPLICATION

The actuators **MODACT MTNED, MTPED** are intended for shifting valves by reciprocating linear motion in circuits of remote control as well as automatic regulation. They can also be used for other devices for which they are suitable with their properties and parameters. Using in special cases should be discussed with the manufacturer.

## OPERATING CONDITIONS

The **MODACT MTNED, MTPED** actuators should withstand the effect of operating conditions and external influences, Classes AA7, AB7, AC1, AD5, AE5, AF2, AG2, AH2, AK2, AL2, AM2, AN2, AP3, BA4 and BC3, according to ČSN Standard 33 2000-3 (mod. IEC 364-3:1993).

When installed on a free area the actuator should be fitted with a light shelter against direct action of atmospheric effects.

If the actuator is used at a location with an ambient temperature under  $-10\text{ °C}$  and/or relative humidity above 80 % or in the tropical atmosphere, the anti-condensation heater which has been built in all actuators, should be always used. One or two heater elements should be connected, as required.

Installation of the actuators at a location with incombustible and non-conducting dust is possible only if this has no adverse effect on their function. It is advisable to remove dust whenever the layer of dust becomes as thick as about 1 mm.

### Notes:

*A sheltered location is considered a space where atmospheric precipitations are prevented from falling at an angle of up to  $60^\circ$  from the vertical.*

*The location of the electric motor should be such that cooling air has free access to the motor and no heated-up blown-out air is drawn in the motor again. For air inlet, the minimum distance from the wall is 40 mm. Therefore, the space in which the motor is located should be sufficiently large, clean and ventilated.*

## Classes of external influences

Basic characteristics - as extracted from ČSN Standard 33 2000-3 (mod. IEC 364-3:1993).

- 1) AA7 – Simultaneous effect of ambient temperature of  $-25\text{ °C}$  to  $+70\text{ °C}$  with relative humidity from 10 % upwards
- 2) AB7 – Ambient temperature to Point 1); minimum relative humidity 10 %, maximum relative humidity 100 % with condensation
- 3) AC1 – Altitude  $\leq 2,000$  m above sea level
- 4) AD5 – Splashing water in all directions
- 5) AE5 – Small dust content of air; mean layers of dust; daily dust fall more than  $35\text{ mg/m}^2$ , but not exceeding  $350\text{ mg/m}^2$
- 6) AF2 – Corroding atmosphere and pollutants; the presence of corroding pollutants is significant.
- 7) AG2 – Average mechanical stress; in current industrial plants
- 8) AH2 – Medium vibrations; in current industrial plants
- 9) AK2 – Serious risk of growth of vegetation and moulds
- 10) AL2 – Serious danger of the occurrence of animals (insects, birds, small animals)
- 11) AM2 – Harmful effect of escaping vagabond currents
- 12) AN2 – Medium solar radiation with intensities  $> 500\text{ W/m}^2$  and  $\leq 700\text{ W/m}^2$
- 13) AP3 – Medium seismic effects; acceleration  $> 300\text{ Gal}$   $\leq 600\text{ Gal}$
- 14) BA4 – Personal abilities; instructed people
- 15) BC3 – Frequent contact with the earth potential; persons coming frequently into contact with „live“ parts or standing on a conducting base

## WORKING MODE

According to ČSN EN 60 034-1, actuators can be operated in S2 load category (the course of load is shown in the picture). The operation time at  $+50\text{ °C}$  shall be 10 minutes, the average mean load thrust value shall be below or equal to 60 per cent of the maximum tripping thrust  $F_v$ . According to ČSN EN 60 034-1, the actuators can also be operated in the S4 mode (interrupted operation with acceleration intervals). The load factor  $N/N+R$  shall be maximum 25 per cent, the longest operation cycle  $N + R$  is 10 minutes. The maximum number of switching actions in automatic control mode is 1200 actions per hour. The average mean load thrust at load factor of 25 per cent and  $50\text{ °C}$  shall not exceed 40 per cent of the maximum tripping thrust  $F_v$ .

The maximum average mean of the load thrust equals the rated thrust of the actuator.

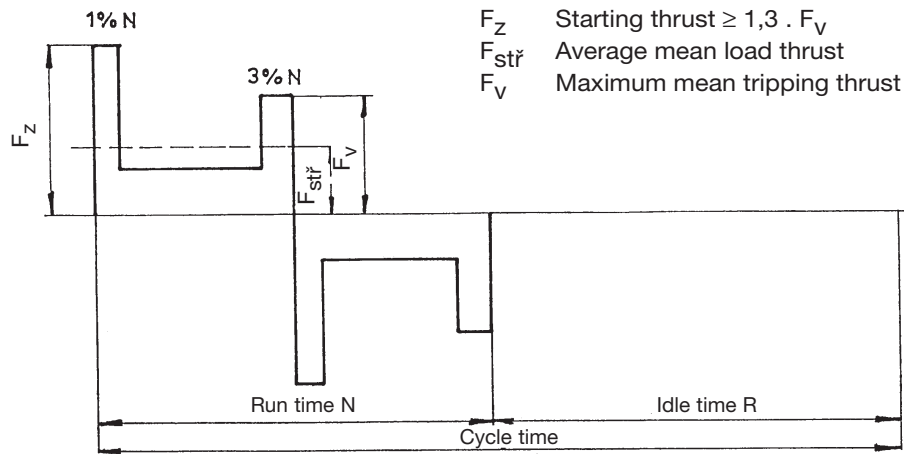

**Course of working cycle**

## Service life of actuators

Service life of actuators is 6 years, at the least.

The actuator intended for shut-off valves must be able to perform at least 10,000 operating cycles (C - O - C).

The actuator intended for regulating purposes must be able to perform at least 1 million cycles with operation time (during which the output shaft is moving) at least 250 hours. Service life in operating hours (h) depends on load and number of switching. Not always, high frequency of switching influences positively accuracy of regulation. For attaining the longest possible faultless period and service life, frequency of switching is recommended to be set to the lowest number of switching necessary for the given process. Orientation data of service life derived from the set regulation parameters are shown in the following table.

Service life of actuators for 1 million starts

Service life [h]	830	1 000	2 000	4 000
Number of starts [1/h]	Max. number of starts 1200	1 000	500	250

## TECHNICAL DATA

### Basic technical parameters

They are given in Table 1.

### Supply voltage

Supply voltage of electric motor: 3 x 220 / 380 V +10 %, -15 %, 50 Hz; +3 % -5 %;  
 3 x 230 / 400 V, +10 %, -15 %, 50 Hz  $\pm 2$  %  
 (or according to data on the rating plate)

### Operating position

Operating position of the actuators MODACT® MTNED, MTPED is arbitrary.

### Tripping thrust

Tripping thrust is set at the manufacturer according to the customer's requirements within the range given in Table no. 1. If setting of tripping thrust is not required maximum tripping thrust of the required type number of the electric actuator is set.

### Self-locking

The actuator is self-locking provided that the load only acts in the direction against motion of the actuator output shaft. Self-locking is ensured by a roller arrest immobilizing the electric motor rotor even in the case of manual control.

In order to observe safety regulations, the actuators cannot be used for driving transportation lifting devices with possible transport of persons or for installations where persons can stand under the lifted load.

## Manual control

Manual control is performed by a hand wheel directly (without a clutch) and is also possible when the electric motor is running (resulting motion of the output shaft is given by the differential gear function). By rotating the hand wheel in the clock-wise direction the actuator output shaft rotates also in the clock-wise direction (when viewing the shaft into the control box). Provided that the valve nut has a left thread, the electric actuator closes the valve.

## Anti-condensation heater

The actuators are fitted with an anti-condensation heater preventing condensation of water vapour.

## Terminal board of electric actuator

The electric actuator is fitted with a terminal board for connecting the actuators to external circuits. The terminal board is fitted with terminals for connecting one conductor of cross-section 2.5 mm<sup>2</sup> or two conductors of identical cross-section up to 1 mm<sup>2</sup>.

## Connector

According to the customer's requirements the MODACT MTNED, MTPED actuators can be fitted with the connector to provide for connection of control circuits. ZPA Pečky, a. s. also supplies a counterpart for the cable. In order to connect the cable to this counterpart it is necessary to use special crimping pliers (supplied by Company on Order No. 0999 000 0021; e-mail: info@contex.cz).

## Insulation resistance

Insulation resistance of electric control circuits against the frame and against each other is min. 20 Mohm. Insulation resistance of the electric motor is min. 1.9 Mohm. After a dump test, insulation resistance of control circuits is min. 2 Mohm.

## Electric strength of electric circuit insulation

Control circuits and circuit of anti-condensation heater	1 500 V, 50 Hz
Electric motor	Un = 1 x 230 V 1 500 V, 50 Hz
	Un = 3 x 400 V 1 800 V, 50 Hz

## Dynamic brake

The brake is an optional accessory to the actuators fitted with electronics DMS2 and DMS2.ED Control. After opening the switching element (contactor or SSR), it induces dynamic braking moment in the motor for several tenths of second. When the actuator is in a standstill no braking moment is exerted. The brake reduces dramatically time of the actuator run-down and regulation is thus more precise. The used brakes BR2 are controlled, impulse for action comes from the control unit. Corresponding variant of the brake is chosen according to the electric motor output and the type of switching elements.

Output up to 550 W:                    **BR2 550**                    (contactor switching)  
   **BR2 BK 550**                    (SSR switching)

Output up to 2.2 kW,  
with external braking resistance:                    **BR 2.2**                    (contactor switching)  
   **BR2 BK 2.2**                    (SSR switching)

If higher outputs are to be braked electric motors of special version with an electromagnetic brake should be used.

## Protection

The electric actuators are fitted with external and internal protecting terminal for securing protection against dangerous shock voltage.

The protecting terminals are marked according to ČSN IEC 417 (34 5550).

## Noise

Average level of acoustic pressure A of electric actuators according to ČSN ISO 3746 (01 1606) must not exceed the value 85 dB (A).

Level of acoustic output A must not exceed 95 dB (A).

## Deviations of basic parameters

Tripping thrust	± 12 % of max. tripping thrust
Shifting speed	-10 % to +15 % of rated value (idle run)

## Protective enclosure

Protective enclosure of actuators: MODACT MTNED - IP 55 according to ČSN EN 60 529  
MODACT MTPED - IP 67 according to ČSN EN 60 529

## DESCRIPTION

In respect of their basic connecting dimensions, the actuators have been engineered for direct mounting to the valve. The connection of the actuator to the valve is provided by means of columns according to ČSN EN ISO 5210, or by means of columns and a flange (in non-standard design MTNED, MTPED 40 only).

For transmission of the output pull-rod motion of the actuator to the valve, the actuator is provided with a coupling, Type A (with female thread), or Type B (with male thread) - see Dimensional sketches and Tab. 2.

### Actuator configuration (Fig.1)

The three-phase asynchronous motor 1 drives via countershaft gearing 2 the sun gear of a differential gear unit enclosed in the supporting actuator box (power gear transmission) 3. In the mechanical power control mode, the crown gear of the planet differential unit is held in a steady position by a self-locking worm gear drive. The handwheel 4, which is connected with the worm, allows manual control to be accomplished even during motor operation.

The output hollow shaft is fixably coupled to the planet-gear carrier. The output shaft of the actuator is extended to the rectilinear mechanism 11 which converts the rotary shaft motion to the rectilinear motion of a pull-rod. The output shaft goes into the control box 5 in which all control devices of the actuator have been concentrated, including position-limit, signalling and torque-limit switches, a position transmitter and the anti-condensation heater.

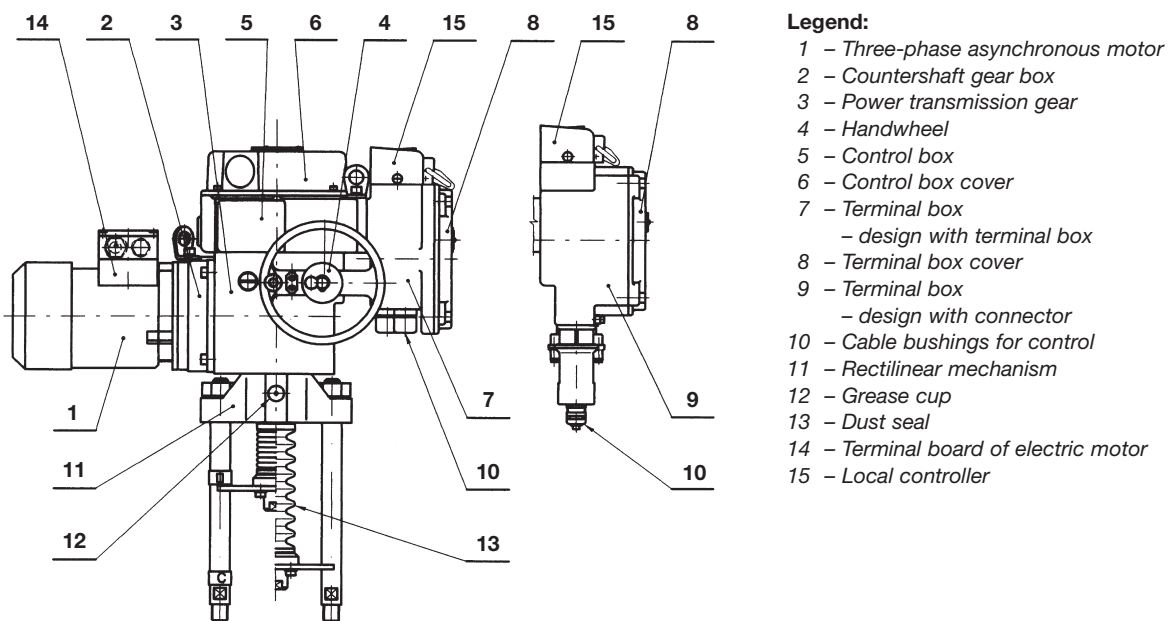

Fig.1 - Configuration of the actuator

The operation of the torque-limit sensor is derived from the axial displacement of a „floating worm“ of the manual control unit which is sensed and transferred to the control box by means of a lever. All controls are accessible after removal of cover 6 of the control box. Access to the terminal box 7 (9) is obtained after removal of cover 8. Cable inlets are secured by cable bushings 10.

The electric motor has its own terminal board 14 with a cable leadthrough. In addition, the pull rod position can be read from the display that can be fitted to the actuator.

## ELECTRONIC OUTFIT

Electro-mechanical control board is replaced with the electronic system **DMS2** or **DMS2 ED**. Both systems scan position of the output shaft and torque of the electric actuator by contact-free magnetic sensors. Long service life is guaranteed for the contact-free sensors that do not get mechanically worn.

The sensor of the output shaft position is absolute and does not require any backup power supply in case supply voltage is disconnected during operation of the electric actuator. Both systems can be set and monitored by a computer with controlling program (set parameter can be backed up on a computer) or manually without a computer (for the electronics DMS2, parameters can be manually set and it can be checked without computer only if the system is equipped with a display and local control). They contain diagnostic functions - error messages on the display, memory of recent failures and number of occurrences of respective failures.

The more simple system **DMS2 ED** substitutes the electro-mechanical board and/or provides for controlling the electric actuator by input analog signal as in the version Control.

The system **DMS2** enables the electric actuator to be used for two-position and three-position regulation or to be connected to the industrial bus bar Profibus.

## DMS2 ED

### Basic outfit:

Control unit	Main part of the system DMS2.ED - includes microcomputer, position sensor, 3 signal lamps LED, 4 push-buttons for simple setting and checking the actuator, connectors for connecting the torque sensor, source board, and interface RS 232 (connection of computer for setting and diagnostics).
Torque unit	
Source unit	Electronic power supply, user's terminal board (connection of power supply and control signals), 2 torque relays, 2 position relays, 2 signalling relays, 1 relay for signalling errors (READY), switch of resistance anti-condensation heater, connectors for connecting electronic brake, resistance heater of analog module, and connector for interconnection with the control unit.

### Optional outfit:

Analog module	output of feed-back signal 4 – 20 mA, in version CONTROL input of control signal 0/4 – 20 mA
Position indicator	LED display
Local control	
Contactors or block of contact-less control	
Electronic brake	

### Parameters:

Scanning of position	Contact-less, magnetic
Scanning of torque	Contact-less, magnetic
Working stroke	see Table 1
Torque blocking	0 – 20 s at reversing in limit positions
Input signal	0(4) – 20 mA with switched on regulator function Local/Remote control, Local open/close
Output signal	7 x relay 250 V AC, 3 A (MO, MZ, PO, PZ, SO, SZ, READY) Position signal 4 – 20 mA max. 500 ohm, active/passive, galvanic-isolated, LED display
Power supply of electronic	230 V AC, 50 Hz, 4 W, over-voltage category II

### Realization:

**Replacement of electric-mechanical board** The provided relay contacts substitute position, torque and signalling micro-switches; current feed-back signal 4 – 20 mA can also be brought out; the actuator is controlled by the superior control system with signals "**open**" and "**close**".

**CONTROL** The electronics covers also function of the regulator; the output shaft position is controlled by analog input signal.

## Function and setting of output relays

The output relays replace end-limit micro-switches; to some extent, function of the output relays differs according to chosen mode of electronics or it can be selected, preferably by the setting program.

## Relays MO, MZ, PO, PZ

Relay	DMS2 ED	DMS2 ED Control
MO	<b>torque open</b> (also changes-over to errors )	<b>motor open</b>
MZ	<b>torque closed</b> (also changes-over to errors )	<b>motor close</b>
PO	<b>position open</b>	<b>torque open</b> (also changes-over to errors ) + optional tripping in position open (parameter Tripping)
PZ	<b>position closed</b>	<b>torque closed</b> (also changes-over to errors ) + optional tripping in position closed (parameter Tripping)

In the version Control, the **function of relay MO/MZ** is same as that of motor relays. Their operation is controlled by:

- **regulation loop** (deviation of required and actual position)
- **active errors**

Any induced active error will change over both relays to a standstill position (coils not energized). In case of errors, the relays with a function of torque relays (in both versions DMS2 ED and DMS2 ED Control) are also controlled.

## Relay SZ, SO, READY

Relay <b>3/SZ</b> - <b>It usually signalizes position closed</b> , it can be changed-over to any offered signalization Relay <b>4/SO</b> - <b>It usually signalizes position open</b> , it can be changed-over to any offered signalization	Relay <b>READY</b> - <b>It usually signalizes errors + warning + not remote</b> , it can be changed-over to any offered signalization
<div style="border: 1px solid black; padding: 5px;"> <div style="display: flex; justify-content: space-between;"> <span>Relé 3 / SZ</span> <span>Relé 4 / SO</span> </div> <ul style="list-style-type: none"> <li>vypnuto</li> <li>poloha O</li> <li>poloha Z</li> <li>moment O</li> <li>moment Z</li> <li>moment a poloha O</li> <li>moment a poloha Z</li> <li>otevřování</li> <li>zavírání</li> <li>pohyb</li> <li>poloha</li> <li>poloha negovaná</li> <li>ovládání-místní</li> <li>ovládání-dálkové</li> <li>ovládání-vypnuto</li> <li>moment O nebo Z</li> <li>pohyb-blikač</li> </ul> </div>	<div style="border: 1px solid black; padding: 5px;"> <div style="display: flex; justify-content: space-between;"> <span>Relé Ready</span> <span>Ready Relay</span> </div> <ul style="list-style-type: none"> <li>OFF</li> <li>warning</li> <li>errors</li> <li>warning or errors</li> <li>errors or no remote</li> <li>errors or warning or no remote</li> <li>torgue O or Z</li> </ul> </div>

## Setting program

The setting program is same for communication with the electronics DMS2ED and DMS2. The users' version can be freely downloaded.

**Note:** In the window "Parameters" of the setting program, column "Access", the word "NO" designates parameters that cannot be changed by the user (change of these parameters is blocked).



Parametr	Změna	Chyba	Přístup	
Setrvačnost [0.1%]			NE	5
Setr. Doběh [0.1s]			NE	6
Necitlivost [%]				1

Parametr – Parameter  
 Změna – Change  
 Chyba – Error  
 Přístup – Access  
 Setrvačnost (0,1 %) – Inertia [0.1 %]  
 Setr. Doběh (0,1 s) – Inertial run-out [0.1 s]  
 Necitlivost (%) – Insensitivity [%]  
 NE – NO

## PROCEDURE OF SETTING PARAMETERS BY MEANS OF PUSH-BUTTONS

For simple programming of required operating parameters, the control unit is fitted with four push-buttons: **MENU**, **P**, **O**, **C** and three signal lamps.

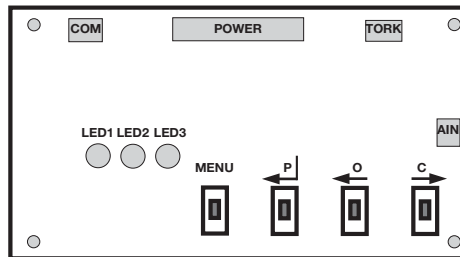

### Colours of diodes:

LED1 – yellow (menu number)  
 LED2 – red (parameter value)  
 LED3 – green

*Push-buttons and signal lamps LED on control unit DMS2.ED.S and DMS2.ED.S90*

Yellow	Red	Green	State
-	-	-	System without feeding
-	-	lit on	Everything OK - working regime (remote, local or switched-off control)
-	blinking	lit on	Error or warning – working regime (remote, local or switched-off control)
lit on	-	lit on	Input or output for setting parameters with push-buttons or setting parameters by means of PC
blinking	-	lit on	Setting parameters with push-buttons
blinking	blinking	lit on	
blinking	blinking	lit on	

### Entry of position Closed, Open and Auto-calibration

- The actuator is set to the position Closed and by long pressing of the push-button **C** the position Closed is entered (without opening the menu).
- The actuator is set to the position Open and by long pressing of the push-button **O** the position Open is entered.
- By means of the push-button **P**, the calibration routine is started; it measures actual inertial masses of the system and stores them into the control unit memory.  
This function is only specified with connected three-position regulation and serves for measuring inertial masses.
- In case that the actuator stroke is to be increased and tripping "**from position**" is set the actuator is switched off in shifting to the position 0 or 100 %. For further change in position, press **C** or **O** and, with permanent depressing of it, the actuator can be further shifted.

### Overview of MENU

#### LISTING THROUGH MENU

- The setting regime is opened by keeping depressed the push-button **MENU** for at least 2 s; the LED1 is then lit up.
- By short pressing of **MENU**, select basic MENU – menu M1 through M8 (LED1 signalizes the menu number); by short pressing of **P**, **O**, **C** you will open them (LED2 signalizes particular parameter).
- By short pressing of **P**, select required value of the parameter. If the parameter can be set to several values they will be changed by short pressing of **P** (number of LED2 blinking indicates its value). By long pressing of **P**, the selected parameter is entered; the entry is confirmed by lit-up LED2.
- By short pressing of **MENU**, gradually set the required menu and parameters.
- After setting all required parameters, the setting menu is left by keeping depressed the push-button **MENU** for at least 2 s. The setting Menu will also be terminated in case that no push-button is depressed within one minute.

#### **MENU 1 – Setting of tripping torques:**

- After opening the menu by means of the push-button **C** or **O**, select the torque to be set.
- By short pressing of **P**, select the value of the parameter 50 – 100 % to be set (5 – 10 blinking of LED2) and by long pressing of the push-button **P** the parameter is stored into the memory.

#### **MENU 2 – Setting of function of signalling relays:**

- Basic setting of the signalling relays is SZ 1 % and SO 99 % of the stroke.
- In case that a different setting is required, it can be changed after shifting the actuator to the required position by means of the push-button **C** or **O**.
- By means of the push-button **P**, basic setting SZ 1% and SO 99% of the stroke is performed.

#### **MENU 3 – Setting of torque blocking in limit positions:**

- By short pressing of **P**, select the value of blocking time 0 – 20 s to be set (0 – 20x blinking of LED2) and by long pressing of the push-button **P** the parameter is stored into the memory.
- By long pressing of the push-button **C**, store the actual position for torque blocking on the Closed side into the memory.
- By long pressing of the push-button **O**, store the actual position for torque blocking on the on the Open side.

#### **MENU 4 – Setting of transducer characteristics:**

- By short pressing of **P**, select the value 4 – 20 mA - 1 blinking of LED2 or 20 – 4 mA – 2x blinking of LED2 and by long pressing of the push-button **P**, store the parameter into the memory.

### **The menus below serve only for setting the board in the version Control.**

#### **MENU 5 – Setting of control signal in 3P regulation:**

- By short pressing of **P**, select the value
  - 4 – 20 mA - 1x blinking of LED2,
  - or 20 – 4 mA - 2x blinking of LED2,
  - or 0 – 20 mA - 3x blinking of LED2,
  - or 20 – 0 mA - 4x blinking of LED2

and by long pressing of the push-button **P**, store the parameter into the memory.

#### **MENU 6 – Setting of insensitivity in three-position regulation:**

- By short pressing of **P**, select the value 1 – 10 % (1 – 10x blinking of LED2) and by long pressing of the **P** push-button, store the parameter into the memory.

#### **MENU 7 – Response to lost control signal in three-position regulation:**

- By short pressing **P**, select the value
  - OPEN - 1x blinking of LED2,
  - or CLOSE - 2x blinking of LED2,
  - or STOP - 3x blinking of LED2

and by long pressing of the push-button **P**, store the parameter into the memory.

#### **MENU 8 – Way of tripping in limit positions in 3P regulation:**

- By short pressing of **P**, select the value
  - TORQUE - 1x blinking of LED2,
  - or TORQUE + PO - 2x blinking of LED2,
  - or TORQUE + PZ - 3x blinking of LED2,
  - or TORQUE + PO+PZ - 4x blinking of LED2

and by long pressing of the push-button **P**, store the parameter into the memory.

## **PROCEDURE OF SETTING PARAMETERS BY PROGRAM DMS2**

- Before putting the actuator into operation, it is necessary to set some parameters of the system by means of the program DMS2 on PC.
- For safety reasons, the system is delivered in the state of an induced error of Calibration when its functions are limited in order to reduce the risk of damaging the actuator by incorrect connection. When the actuator is controlled by the program DMS2 its operation is stopped if any torque is induced.

### **Working torque**

- Check and, if necessary, set the value of the working torque 50 – 100 % in the program DMS2.

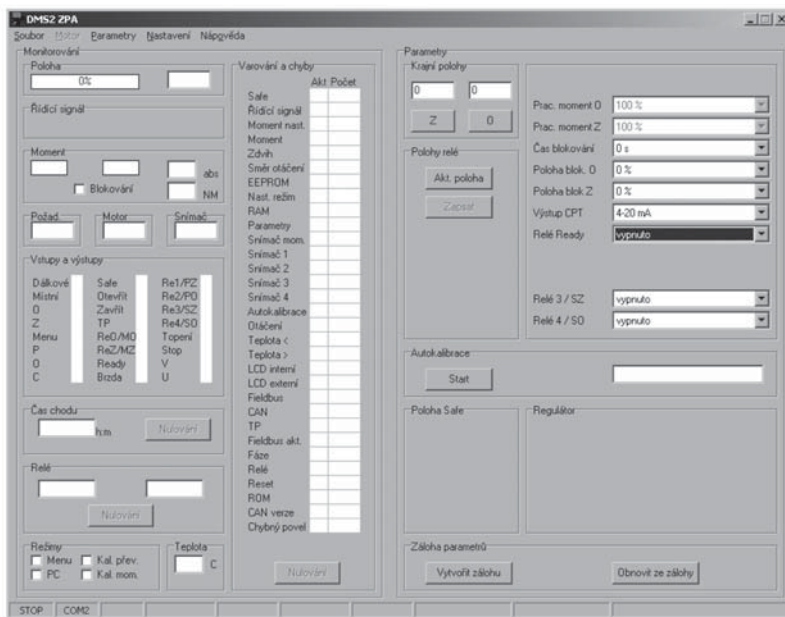

Main window of setting program

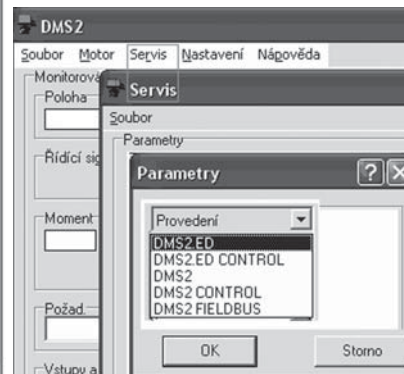

Selection of electronics

## Limit positions – working stroke

- Position Z:
  - Move to the position Closed manually or by means of the menu Motor in the program DMS2.
  - The actuator can only be controlled by means of the program if no torque is induced. The torque must be left manually.
  - Pressing the push-button Z to confirm your consent with the entry.
- Position O:
  - Move to the position Open manually or by means of the menu Motor in the program DMS2.
  - The actuator can only be controlled by means of the program if no torque is induced. The torque must be left manually.
  - Pressing the push-button O to confirm your consent with the entry.

## Auto-calibration (in connection Control only)

- The auto-calibration can only be started by means of the program if no torque is induced. The torque must be left manually.
- The auto-calibration is started by the push-button Start in the program DMS2.
- Wait until the auto-calibration ends; the information on its course is signaled next to the push-button Start.

## Other parameters

Check and, if necessary, change other parameters:

Control signal	4 – 20 mA	20 – 4 mA	0 – 20 mA	20 – 0 mA
Insensitivity	1 – 10 %			
Function in case of error	Open	Close	Stop	To position
Time of torque blocking in limit positions	0 – 20 s (default 5 s)			
Position of torque blocking in limit positions	1 – 10 %			
Output of position signal	4 – 20 mA	20 – 4 mA		
Function READY	Combined error			

**Note:** Signal READY is brought out as the relay contact on the terminal board. If an error or warning state has not been detected (setting is possible of what should be evaluated as an error or warning) the contact is closed; in case of an error, warning or if the power supply is electronically cut out the contact is opened. The state of the relay READY is indicated by the LED diode on the source board.

## AUTO-DIAGNOSTICS

DMS2.ED performs continuously its diagnostics and, in case a problem is found, it signalizes warning or error.

Warning or error are signalized by LED, display, and/or relay Ready.

The warning has no influence on the system operation; the error stops the drive.

Assignment or switching-off of the warning and error is set in the window "Warnings and errors" of the setting program (it is opened by clicking on one of the parameters Warning 1 – 4 or Error 1 – 4 in the window "Parameters").

### List of warnings and errors

No.	Name	Warning <sup>1</sup>	Error <sup>1</sup>	Description
1	Safe *	X		Input Safe activated
2	Control signal	X		Value of control signal $\leq 3$ mA (applies to ranges 4 – 20 or 20 – 4 mA)
4	Torque		X	Induced torque off limits or torque sensor disconnected
6	Thermal protection		X	Thermal protection input activated
7	Sense of rotation		X	Reverse sense of rotation (with function Control only)
8	EEPROM	X		Incorrect control sum of parameters in EEPROM
9	RAM		X	Incorrect control sum of parameters in RAM
10	Parameters		X	Incorrect parameters in EEPROM
11	Setting regimes	X		Setting regimes z push-buttons or PC
12	Torque sensor		X	Disconnected or faulty torque sensor
13	Sensor 1		X	Error of position sensor 1 (lowest degree)
14	Sensor 2		X	Error of position sensor 2
15	Sensor 3		X	Error of position sensor 3
16	Sensor 4		X	Error of position sensor 4 (highest degree)
17	Calibration	X		Auto-calibration not carried out
18	Setting torque		X	Incorrectly set torques (parameters TORQUE Open/Close 50/100%)
19	Stroke		X	Incorrectly set stroke (parameters position Open/Close)
21	High temperature	X		Max. permitted temperature exceeded (parameter Temperature max)
22	Low temperature	X		Min. permitted temperature exceeded (parameter Temperature min)
23	LCD internal *	X		Internal LCD display does not communicate or is not added in the parameter of CAN configuration
24	LCD external *	X		External LCD display does not communicate or is not added in the parameter of CAN configuration
25	Fieldbus *	X		Module of industrial bus does not communicate or is not added in the parameter of CAN configuration
26	CAN *	X		Error of CAN bus (short-circuit, interruption, only sensor communicates)
27	Fieldbus activity *	X		Connection to industrial bus inactive
28	Phase *		X	Reverse order of phases or some phase missing
29	Relay service life	X		Exceeded service life of relay for Open/Close of Control (parameter Relay service life)
30	Reset	X		Non-standard Reset of unit induced (watchdog etc.)
31	ROM		X	Wrong control sum of program in ROM
32	CAN version *	X		Sensor, LCD display or Fieldbus module have incompatible firmware versions
33	Erroneous command *		X	The commands Open and Close entered at the same time
34	Wrong inertia	-	-	Auto-calibration measured wrong inertia (for auto-calibration only)
35	Wrong run-out	-	-	Auto-calibration measured wrong run-out (for auto-calibration only)
41	Erroneous position		X	The servo-drive is in the position 25 % beyond the working stroke

<sup>1</sup>) The assignment can be changed depending on the version of the firmware of the sensor control unit.

\* Valid for DMS2 only.

## Memory of number of induced errors

- For all detected warnings and errors, DMS2.ED uses a counter of occurrence of these warnings and errors during the system operation.
- Values of the counters are stored into the EEPROM memory and are preserved even in case of the mains supply fall-out.
- The error counters can be read and erased by means of a program for PC.
- The counters can be erased by a PC program with the authorization level "SERVICE".

## Memory of recently induced warnings and errors

- DMS2.ED stores three recently induced warnings and errors in the EEPROM memory.
- Recent warnings and errors can be displayed and erased by means of the PC program.

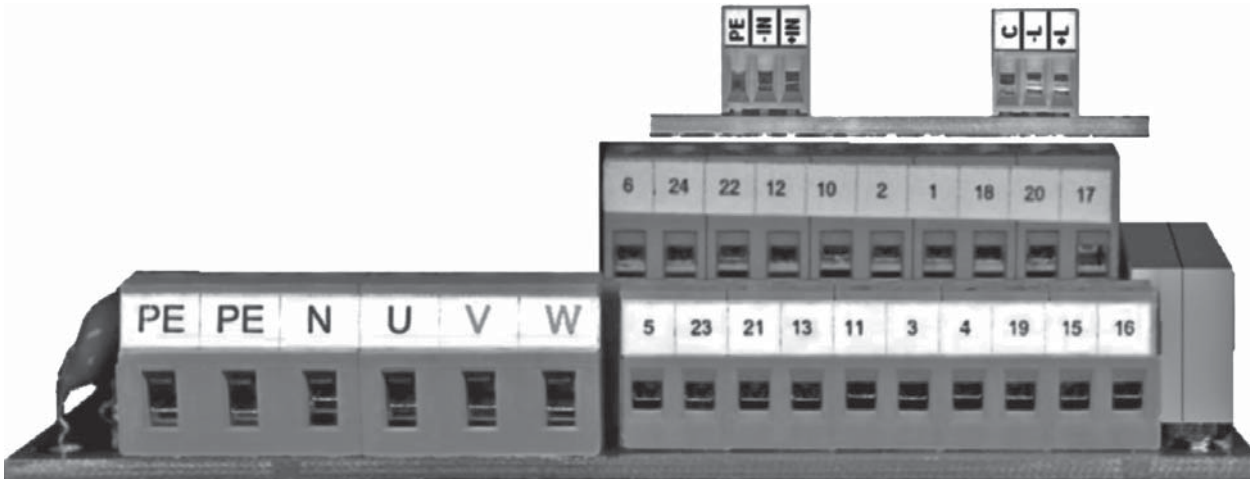

*Terminal board of actuator with electronics DMS2ED.*

If the actuator is of the single-phase version the power supply is connected only to terminals **E, N U**. The terminals **V, W** remain non-connected. If the actuator is of the version "Replacement of electric-mechanical board" with three-phase electric motor without power relays, the electric motor is connected to a separate terminal board (not shown here).

Wiring diagram of electronics **DMS2 ED** in version **Substitution of electro-mechanical board**  
**(actuators MODACT MTNED, MTPED)**

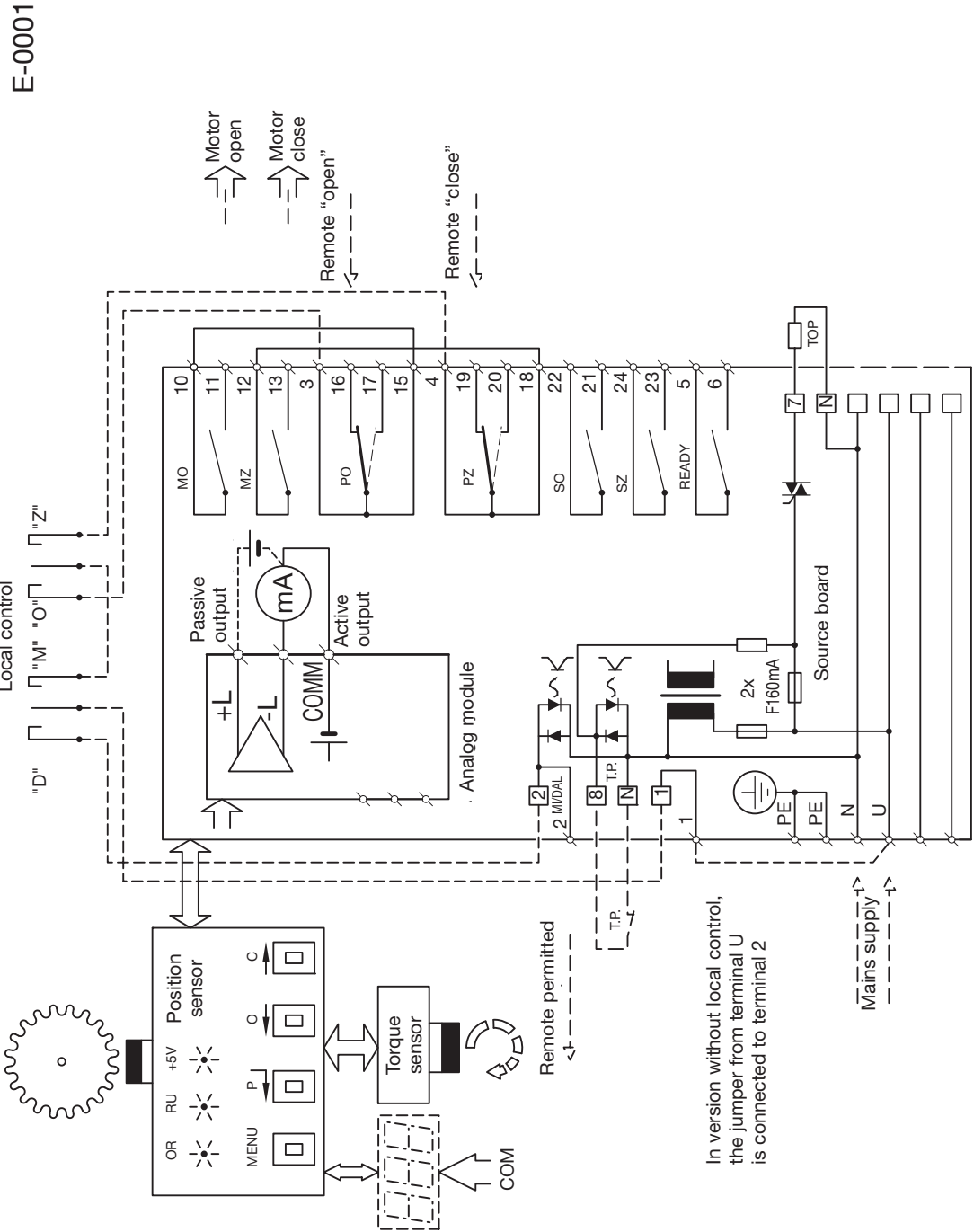

**Note:** Here, contacts of relays MO, MZ, SO, SZ are shown with power supply switched off; with power supply switched on contacts PO, PZ are shifted to the position drawn in dashed line.

Wiring diagram Substitution of electro-mechanical board with contactors and thermal relay  
(actuators MODACT MTNED, MTPED)

E-0002

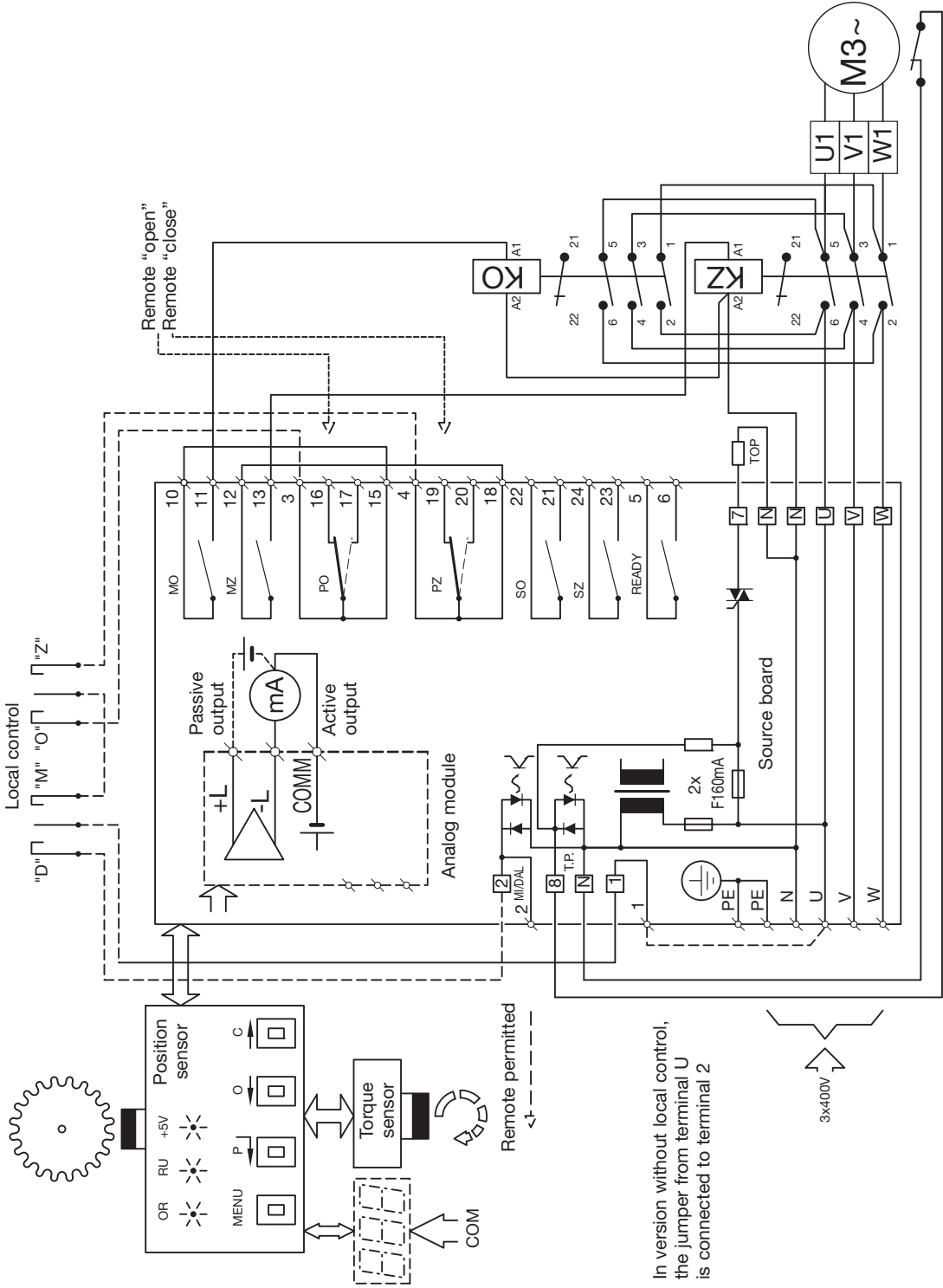

In version without local control, the jumper from terminal U is connected to terminal 2

Wiring diagram of electronics **DMS2 ED** in version **Control (actuators MODACT MTNED, MTPED)**

E-0003

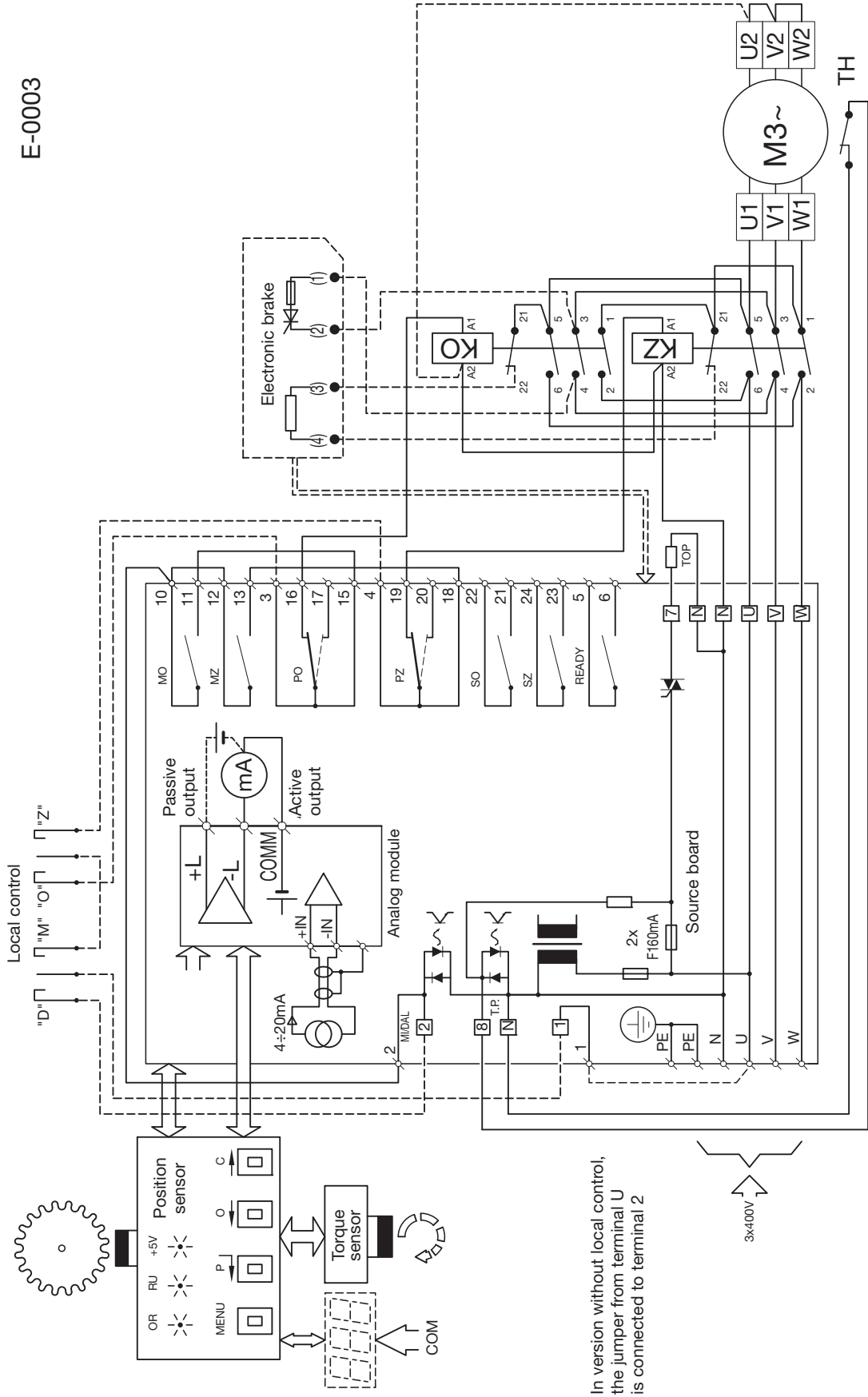

In version without local control, the jumper from terminal U is connected to terminal 2

**Note:** Here, contacts of relays MO, MZ, SO, SZ are shown with power supply switched off; with power supply switched on, PO, PZ are shifted to the position drawn in dashed line.



Example of wiring diagram of electronics **DMS2 ED** in version **Control** with contact-less switching of electric motor

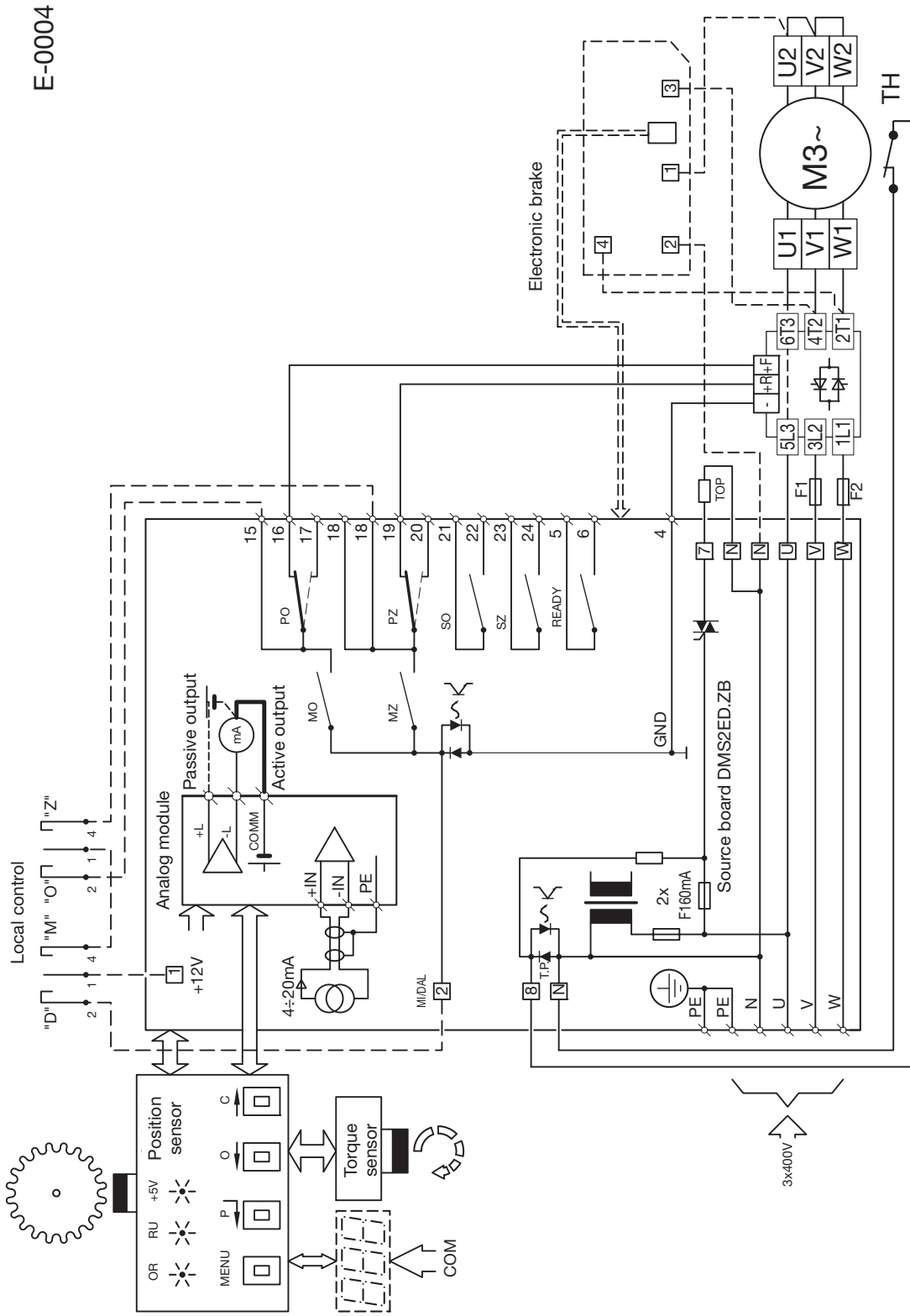

E-0004

**Note:** Here, contacts of relays MO, MZ, SO, SZ are shown with power supply switched off; with power supply switched on, PO, PZ are shifted to the position drawn in dashed line.

## DMS2

### Main features of DMS2:

- Complete control of the actuator operation by two and three-position regulation or connection to an industrial bus-bar Profibus.
- Well-arranged signalization of operating and service data on a character-type LCD display 2 x 12.
- Auto-diagnostics of error messages on an LCD display, memory of recent failure and number of occurrences of respective failures.
- Parameter setting by means of PC program or local control in case the actuator is fitted with the local control.

### Basic outfit:

The control unit is a main part of the system DMS2; it includes:

- Micro-computer and memory of parameters
- Position sensors
- 2 signalling LED
- Connectors for connecting torque sensor, boards of relays and two-position inputs, source boards, communication adapter, LCD display, and local control.

### The torque unit provides for scanning torque by a contact-less sensor.

#### Source unit - two types:

DMS2.ZAN for two-position or three-position control of the actuator with binary signals "Open" and "Close" or with analog signal 0(4) – 20 mA.

DMS2.ZPR for controlling the actuator by industrial bus bar Profibus.

Both units contain power supply sources for electronics, two relays for controlling power switches (contactors or contact-free switches) of the electric motor, circuit of watching phase sequence, circuits for connecting anti-condensation heater, and input terminals for connecting thermal contact from the electric motor. The units are fitted with power terminal board for connecting power supply. The units are fitted with a connector for display and local control.

#### Unit DMS2ZAN also includes:

- input circuits for two-position and three-position control of the actuator and terminals for connecting external control signals;
- input of signal SAFE - information on external failure;
- relay – total of five; four (signalizing) of them can be set for reporting on position, torque, and/or other operating conditions of the actuator; the fifth one (Ready) is used for reporting on errors, warning, and other states when the actuator cannot perform its function without errors, and terminals to which the relay contacts are connected;
- circuits of feedback current signal - information on position of the actuator output shaft.

#### Unit DMS2.ZPR also includes:

- circuits for communication with the superior control system via the industrial bus bar Profibus DP; input and output terminals for connecting the bus bar and terminating resistors with a switch.

**Unit of display** - two-line display, 2 x 12 alpha-numeric characters.

**Unit of push-buttons** - sensors of pushbuttons "Open", "Close", "Stop", and the rotary switch "local", "remote", "stop".  
*The actuator can be fitted with contactors or contact-free switching of the electric motor; it can be fitted with an electronic brake.*

## PROCEDURE OF SETTING PARAMETERS BY PROGRAM DMS2

Before putting the actuator into operation, it is necessary to set some parameters of the system by means of the program DMS2 on PC.

**Warning:** *For safety reasons (to reduce the risk of damaging the actuator by incorrect connection), the system is delivered in the state of an induced error of Calibration when its functions are limited. When the actuator is controlled by the program DMS2 its operation is stopped if any torque is induced.*

**Note:** *The setting program is same for the electronics DMS2ED. Main window and window Electronics selection – see figure on page 9.*

### Working torque

- Check and, if necessary, set the value of the working torque 50 – 100 % in the program DMS2.

## Tripping in limit positions

- Check and, if necessary, set the way of tripping in limit positions:
  - Torque
  - Torque + position O
  - Torque + position Z
  - Torque + position Z+O

## Limit positions – working stroke

- Position Z:
  - Move to the position Closed manually or by means of the menu Motor in the program DMS2.
  - The actuator can only be controlled by means of the program if no torque is induced. The torque must be left manually.
  - Press the push-button Z to confirm your consent with the entry.
- Position O:
  - Move to the position Open manually or by means of the menu Motor in the program DMS2.
  - The actuator can only be controlled by means of the program if no torque is induced. The torque must be left manually.
  - Press the push-button O to confirm your consent with the entry.

## Auto-calibration

- The auto-calibration can only be started by means of the program if no torque is induced. The torque must be left manually.
- The auto-calibration is started by the push-button Start in the program DMS2.
- Wait until the auto-calibration ends; the information on its course is signaled next to the push-button Start.

## Other parameters

Check and, if necessary, change other parameters:

Control signal	4 – 20 mA	20 – 4 mA	0 – 20 mA	20 – 4 mA
	2-position	Bus-bar		
Insensitivity	1 – 10 %			
Function SAFE	Open	Close	Stop	To position
Active SAFE	0 V	230 V		
Time of torque blocking in limit positions		0 – 20 s		
Position of torque blocking in limit positions		1 – 10 %		
Output of position signal	4 – 20 mA	20 – 4 mA		
Function READY	Combined error	Error code		
Ready - local	On	Off		
Relays 1 – 4	Off	Position O	Position Z	
	Torque O	Torque Z	Torque and position O	Torque and position Z
	Opening	Closing	Movement	
Positions of relays 1 – 4	0 – 100 %			

**Note:** SAFE – input of information on error of an external device can be set so that the actuator would respond as if the error were its own.

## Auto-diagnostics

Table List of warnings and errors – same as for the electronics DMS2 ED (page 12).

## Memory of number of induced errors

- For all detected errors, DMS2 uses a counter of occurrence of these errors during the system operation.
- Values of the counters are stored into the EEPROM memory and are preserved even in case of the mains supply failure.
- The error counters can be read and erased by means of the program for PC.

## Memory of recently induced errors

- DMS2 stores 3 recently induced errors into the memory EEPROM.
- Errors can be displayed and erased by means of the program on PC or by switches of local/remote control.
- Displaying and resetting by means of switches of local/remote control:
- Display – position OFF and position O or C.
- Reset – after switching-over from the error display to remote control.

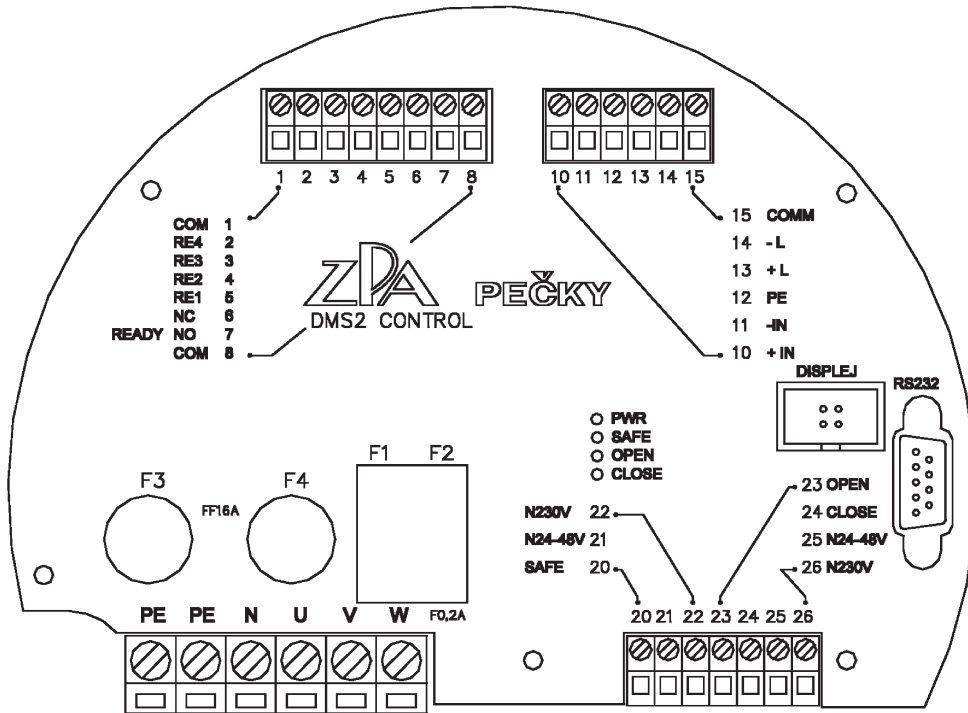

**Terminal board DMS2 Analog**

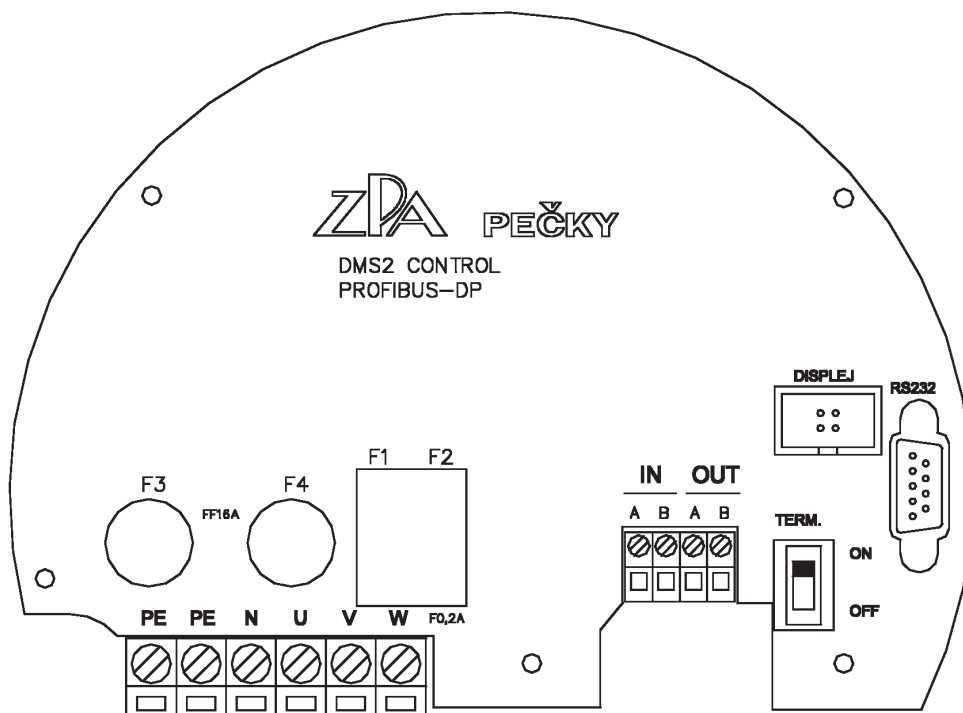

**Terminal board DMS2 Profibus**

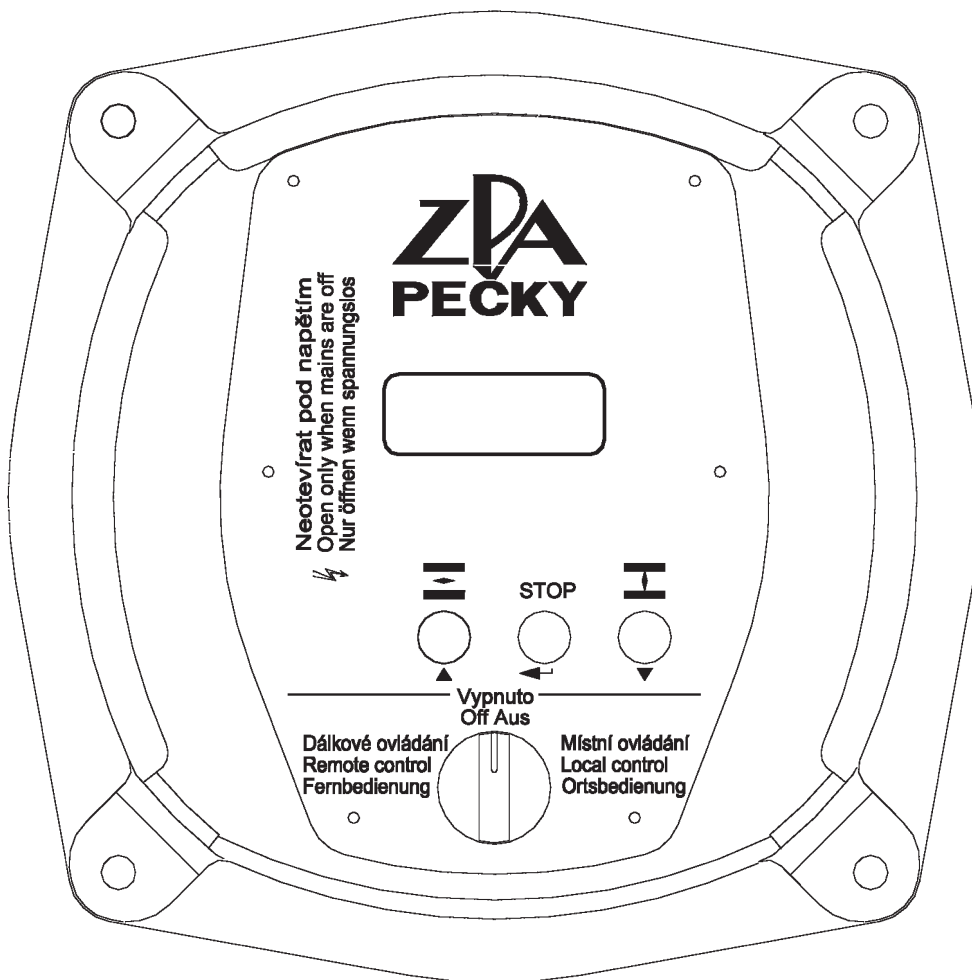

**DMS2 - local control and display**

**Note:** The setting program enables data to be copied from the memory of parameters of the electronics DMS2 and DMS2ED into the computer as a file with suffix „.par“ (in the example in the figure the file 52 030.par is created in the directory Flash). The file can serve as a back-up for the case that it will be necessary to replace the position sensor in the given actuator and to set it in the same way as the replaced one; or it can be sent as an enclosure to e-mail to the manufacturing or service firm in solving possible problems..

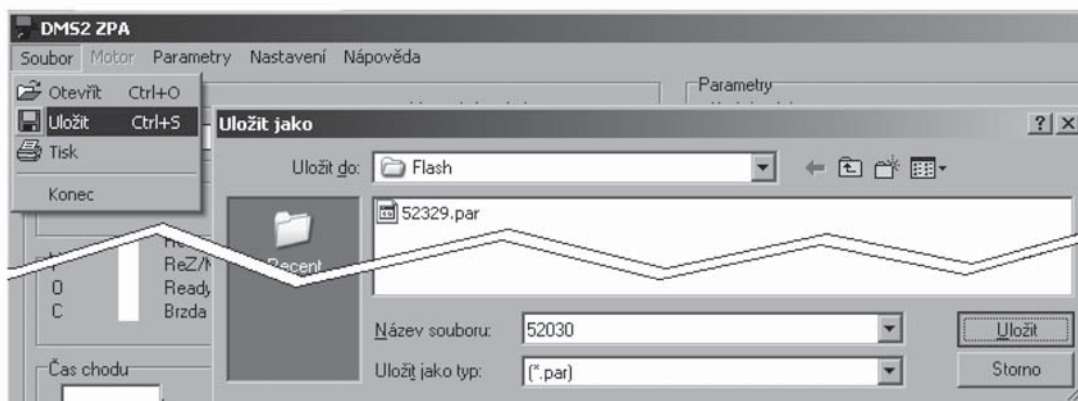

Wiring diagram of electronics **DMS2 Analog** in version **Control (actuators MODACT MTNED, MTPED)**

E-0006

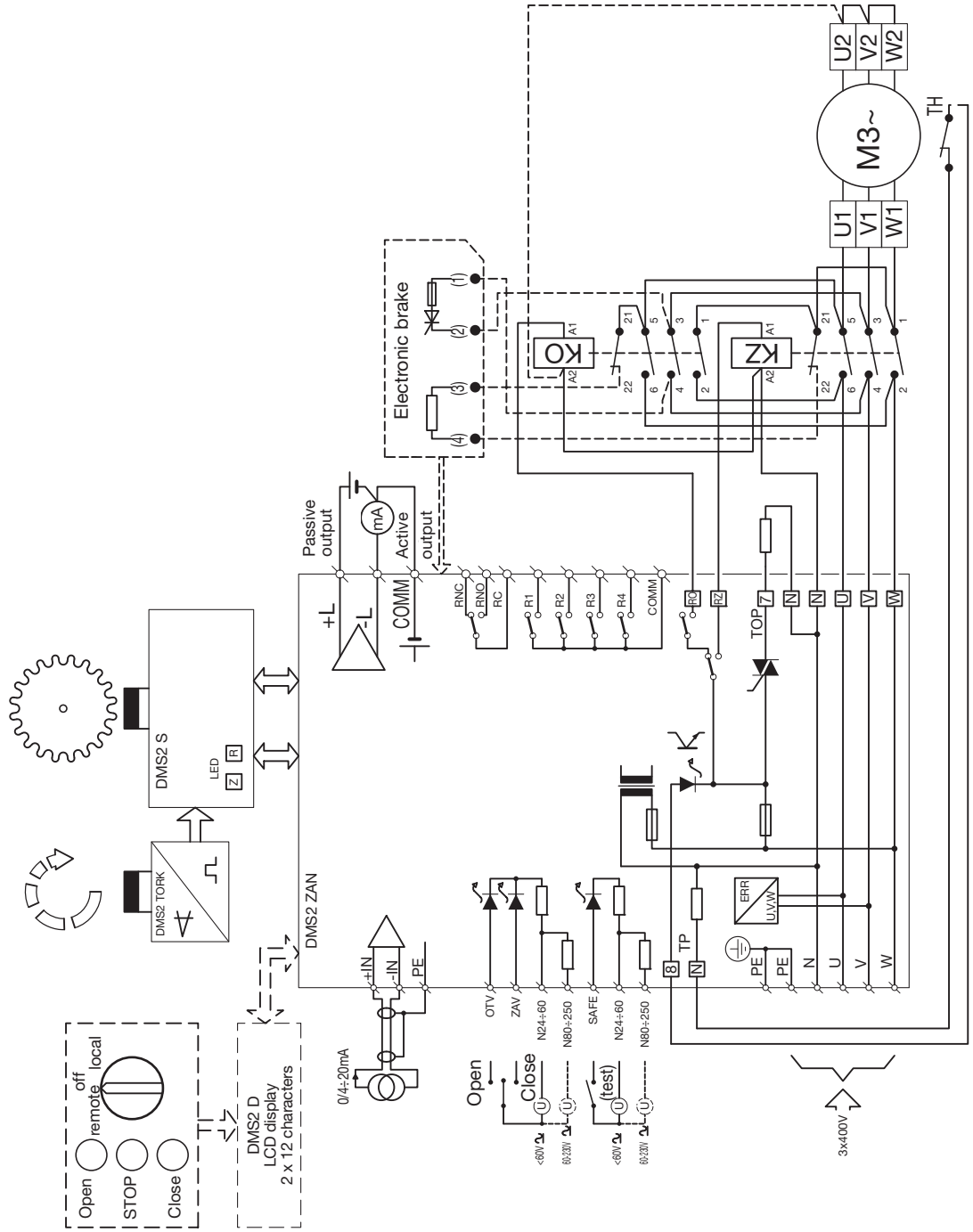

Wiring diagram of electronics DMS2 Profibus in version Control (actuators MODACT MTNED, MTPED)

E-0008

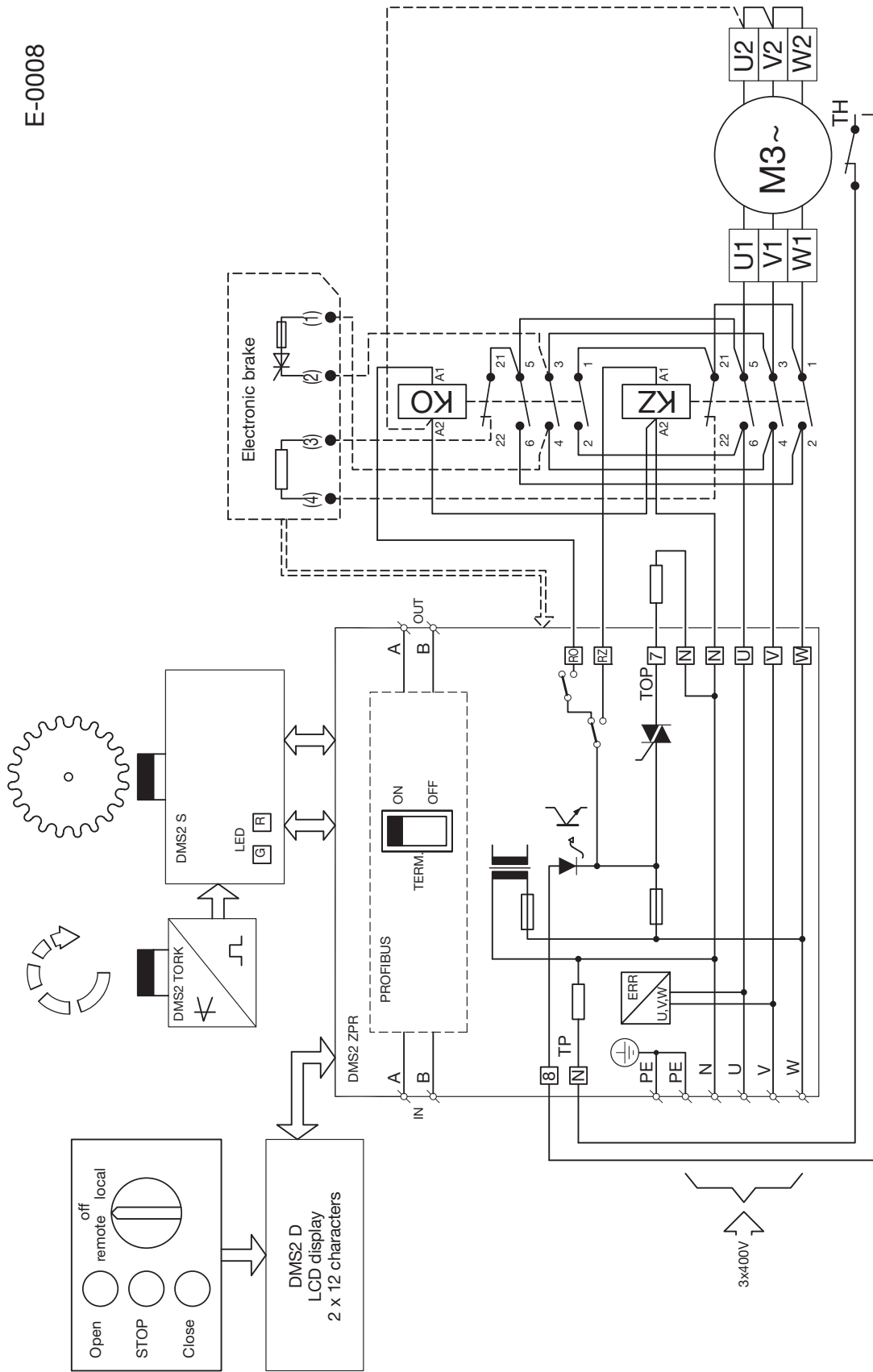

**Table 1 – MODACT MTNED, MTPED electric actuators**  
– basic technical parameters

Basic technical parameters:												
Type	Adjustment range of tripping thrust [kN]	Starting thrust [kN]	Speed [mm/min]	Stroke [mm]	Electric motor					Weight [kg]	Type Number	
					Type	Power [W]	Revolutions per minute [1/min]	$I_n$ (400 V) [A]	$\frac{I_z}{I_n}$		basic 1 2 3 4 5	additional 6 7 8 9 10
MTNED 15 MTPED 15	11,5 - 15	17	50	10 - 100	1xx7070-6AA	180	850	0,74	2,3	33	5 2 4 4 2	x x 0 x x ED
			80		1xx7070-6AA	180	850	0,74	2,3			x x 1 x x ED
			125		1xx 7070-4AB	250	1350	0,77	3,0			x x 3 x x ED
			36		1xx7073-8AB	120	645	0,51	2,2			x x 2 x x ED
			27		1xx7073-8AB	120	645	0,51	2,2			x x A x x ED
MTNED 25 MTPED 25	15 - 25	32,5	50	10 - 100	1xx7070-6AA	180	835	0,74	2,3	33	5 2 4 4 2	x x 4 x x ED
			80		1xx7070-6AA	180	835	0,74	2,3			x x 5 x x ED
			125		1xx7070-4AB	250	1350	0,77	3,0			x x 6 x x ED
			36		1xx7073-8AB	120	645	0,51	2,2			x x 7 x x ED
			27		1xx7073-8AB	120	645	0,51	2,2			x x 8 x x ED
MTNED 40 MTPED 40 <sup>1)</sup>	25 - 40	52	80	20 - 120	1xx7083-6AA	550	910	1,6	3,4	60	5 2 4 4 3	x x 1 x x ED
			125		1xx7080-4AA	550	1395	1,45	3,9			x x 2 x x ED
MTNED 63 MTPED 63	40 - 63	82	80	20 - 120	1xx7090-6AA	750	915	2,1	3,7	63	5 2 4 4 3	x x 4 x x ED
			125		1xx7090-4AA	1100	1415	2,55	4,6			x x 5 x x ED

**Notes:**  
<sup>1)</sup> Design with clutch internal threads and a flange (non-standard) is available only in the design variants, Type No. 52 443.x21xNED and 52 443.x22xNED (Type MTNED, MTPED 40).

**Specification of respective positions in the type number:**

6th place	Connection (terminal board/connector), electronics type		Table No. 3	
7th place	Connecting dimensions	for type 52 442	Table No. 2	
		for type 52 443	according to Fig. 3, 4	1
			according to Fig. 5	2
8th place	Force, speed		Table No. 1	
9th place	Type of electronic	DMS2	0	
		DMS2 ED	Table No. 4	
10th place	Protective enclosure	IP 55	NED	
		IP 67	PED	

**Table 2 – Connecting dimensions – specification of the 7th place of Type No. 52 442.xxxxxED**

Design	Type number	
	basic	additional
Aa1I	52 442	x0xxx
Aa1II	52 442	x1xxx
Aa1III	52 442	x2xxx
Aa2I	52 442	x3xxx
Aa2II	52 442	x4xxx
Aa2III	52 442	x5xxx
Ab1I	52 442	x6xxx
Ab1II	52 442	x7xxx
Ab1III	52 442	x8xxx
Ab2I	52 442	x9xxx
Ab2II	52 442	xAxxx
Ab2III	52 442	xBxxx

Design	Type number	
	basic	additional
Ba1I	52 442	xCxxx
Ba1II	52 442	xD1xxx
Ba1III	52 442	xExxx
Ba2I	52 442	xFxxx
Ba2II	52 442	xGxxx
Ba2III	52 442	xHxxx
Bb1I	52 442	xIxxx
Bb1II	52 442	xJxxx
Bb1III	52 442	xKxxx
Bb2I	52 442	xLxxx
Bb2II	52 442	xMxxx
Bb2III	52 442	xPxxx
Bg2I	52 442	xRxxx

Deliveries in design III with coupling M 10 x 1 upon special request only.



Spacing of columns	A		160 mm
	B		150 mm
„Closed“ position	a	Short columns	30 mm
	b	Long columns	74 mm
	g	Column length 130 mm	130 mm
Thread of coupling	I		M 20 x 1,5
	II		M 16 x 1,5
	III		M 10 x 1

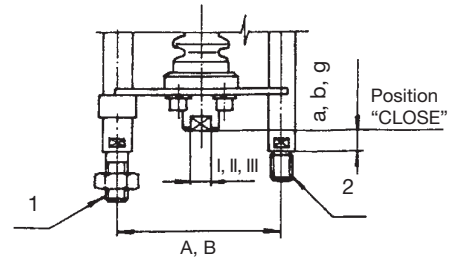

**Table 3 – Version, electric connection, electric outfit – specification of the 6th place of Type No.**

Electronics	Terminal board	Connector	Terminal board, brake	Connector, brake
DMS2 ED (version: Electronic board or contactors - see Table No. 4)	E	F	H	K
DMS2 ED, contact-less switches	A	B	C	D
DMS2, Profibus, contactors	P	T	U	Y
DMS2, Profibus, contact-less switches	I	J	L	M
DMS2 two- or three-position control*), contactors	R	V	W	1
DMS2 two- or three-position control*), contact-less switches	N	S	2	Z

\*) The two or three-position control of the actuator will be installed at the manufacturers plant. Unless otherwise specified in the purchasing order, the three-position control will be installed (4 – 20 mA signal control).

**Table 4 – Outfit of electronics DMS2 ED – specification of the 9th place of Type No.**

Outfit <b>DMS2 ED</b>	Character on 9th place																								
	0	1	2	3	4	5	6	7	8	9	A	B	C	D	E	F	H	J	K	L	M	N	V	W	
Local control		x		x		x		x		x		x		x		x		x		x		x		x	
Display			x	x			x	x			x	x			x	x			x	x				x	x
Contactors or contact-less switch					x	x	x	x					x	x	x	x					x	x	x	x	x
Analog module	Transmitter									x	x	x	x	x	x	x	x	x	x	x	x	x	x	x	x
	Regulator																	x	x	x	x	x	x	x	x

**Note:** If the electric motor used is not fitted with a built-in temperature sensor the contactors include a thermal relay. If the actuator has DMS2ED electronic system in configuration Electromechanics board replacement, the electronic brake will not be delivered.

Dimensional sketch of **MODACT MTNED, MTPED 15, MTNED, MTPED 25**, electric actuators, Type No. 52 442.xxxxNED, 52 442.xxxxPED

- with connector

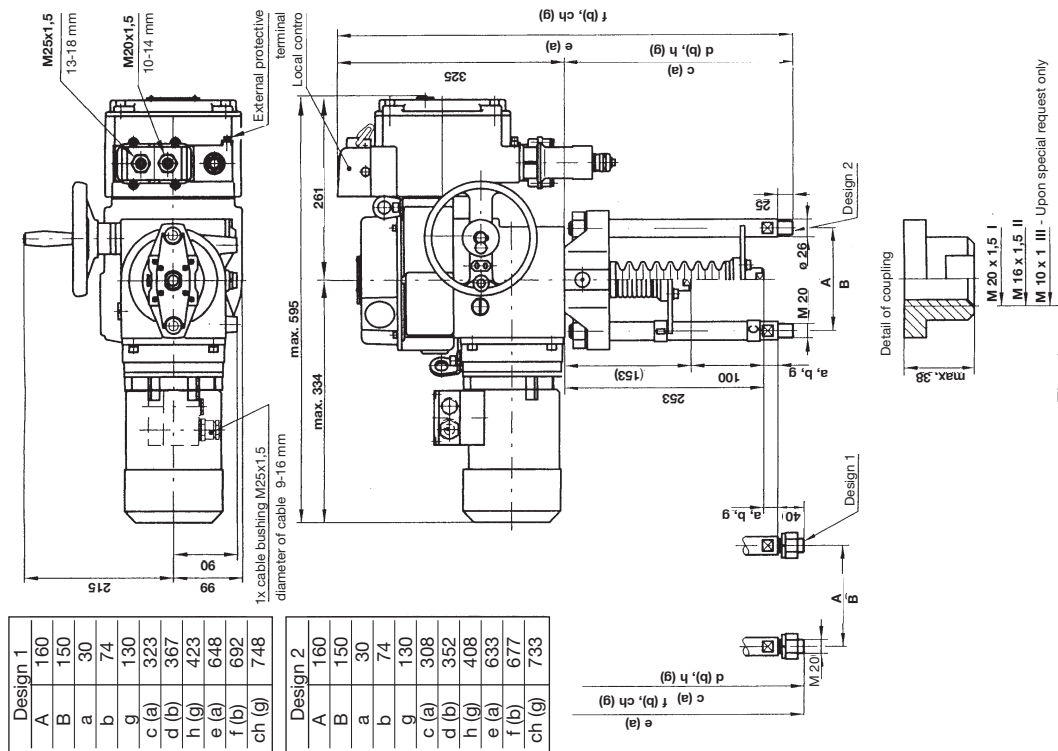

Fig. 1

Dimensional sketch of **MODACT MTNED, MTPED 15, MTNED, MTPED 25** electric actuators, Type No. 52 442.xxxxNED, Type No. 52 442.xxxxPED

- with block of terminals

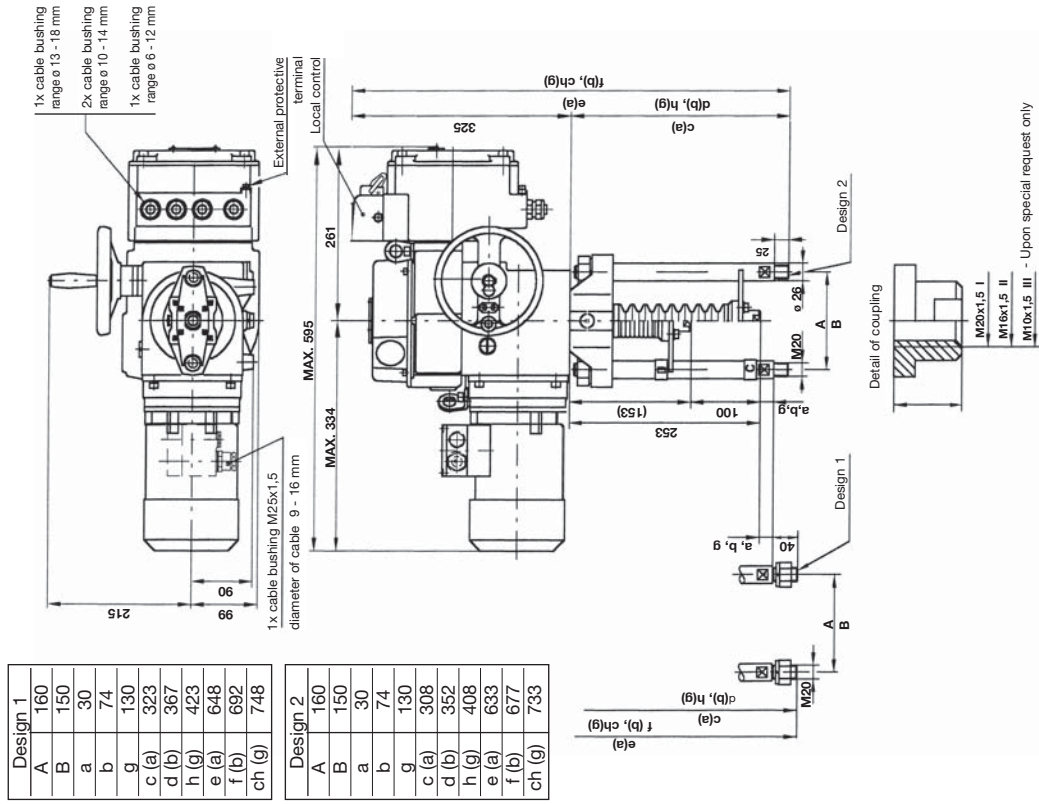

Fig. 2

**Note:** For actuators MODACT MTNED, the switchboard box has threads for bushings: 3 pcs. M20 x 1.5; 1 pc. M20 x 1.5; 1 pc. M25 x 1.5. For actuators MODACT MTPED, the switchboard box has bushings: 1 pc. M25 x 1.5, range of Ø 13 - 18 mm; 2 pcs. M20 x 15 range of Ø 10 - 14 mm; 1 pc. M20 x 1.5 range of Ø 6 - 12 mm. The electric motor (except for the actuator version with the switchboard box) is always delivered with the switchboard box. Connector Harting is always fitted with cable bushings.

Dimensional sketch of **MODACT MTNED, MTPED 40, MTNED, MTPED 63** electric actuators, Type No. 52 443.x1xxNED, 52 443.x1xxPED

- with Harting connector

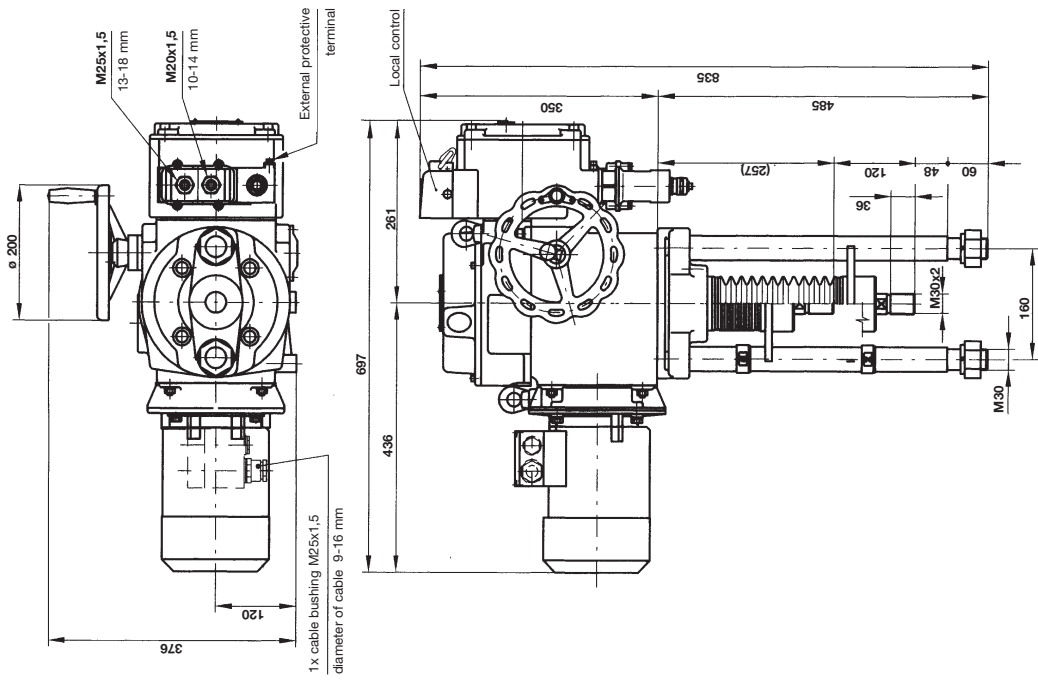

Fig. 3

Dimensional sketch of **MODACT MTNED, MTPED 40, MTNED, MTPED 63** electric actuators, Type No. 52 443.x1xxNED, 52 443.x1xxPED

- with block of terminals

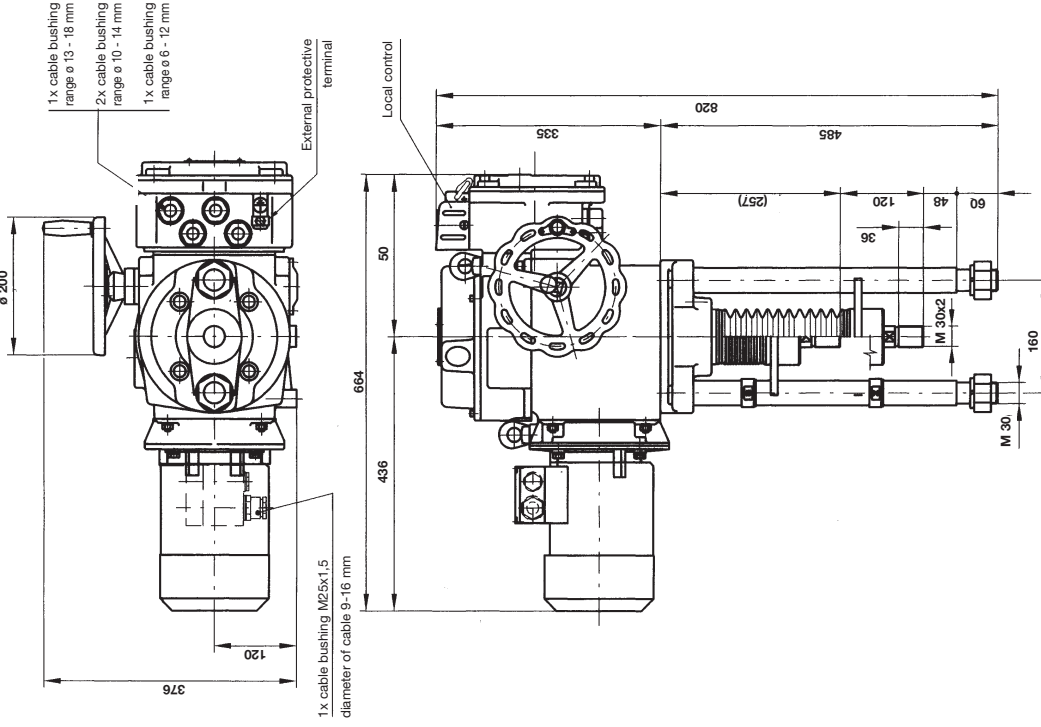

Fig. 4

Dimensional sketch of **MODACT MTNED 40, MTPED 40** electric actuators,  
 Type No. 52 443.x2xxNED, 52 443.x2xxPED  
 – design with flange - non standard

– with block of terminals

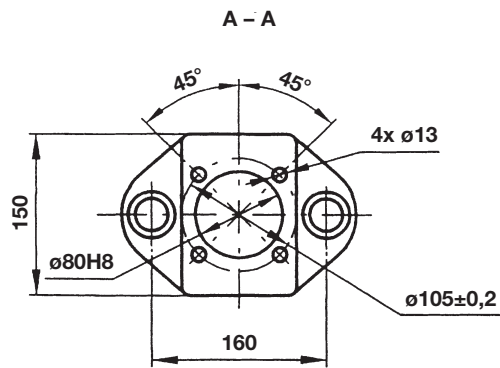
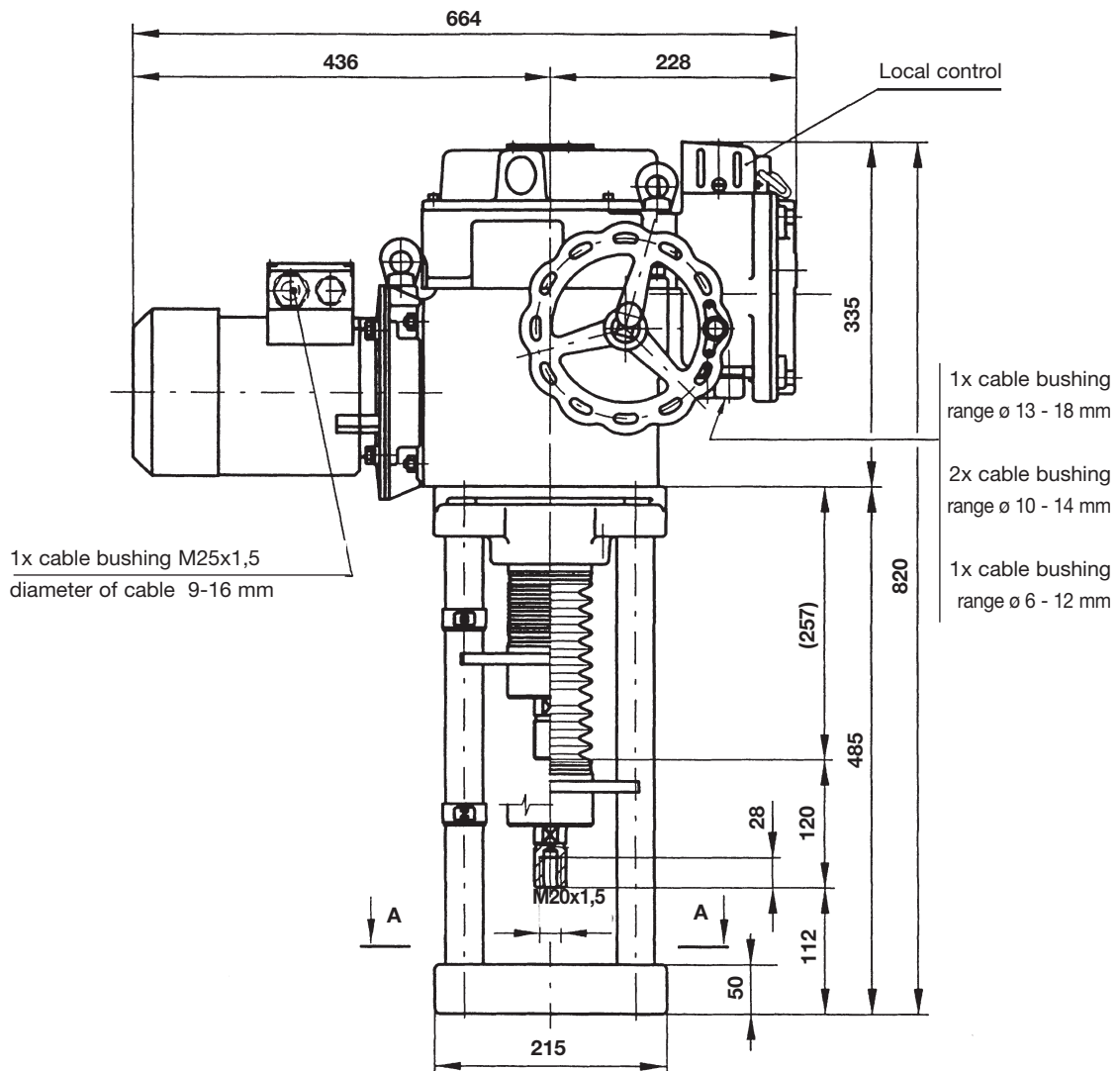

Fig. 5

## PACKING AND STORING

For inland freight, the actuators are unpacked. However, they should be transported by covered conveyances or in transport containers.

For delivery abroad, the actuators should be packed, the type and design of package being adapted to the transport conditions and the distance of the place of destination.

Upon receipt of the actuator from the factory, it is essential to check that no damage was caused during transport and to compare the data on the actuator rating plates with those contained in the order and accompanying documentation. Any discrepancy, defect or damage should be immediately reported to the supplier.

When the unpacked actuator is not immediately installed it should be stored at a dust-free location with a temperature within the range of  $-25\text{ }^{\circ}\text{C}$  to  $+50\text{ }^{\circ}\text{C}$  and relative humidity up to 80 % where there are neither aggressive gases nor vapours and which is secured against the harmful effects of climatic conditions.

If the actuator is to be stored for a longer period than 3 years then, prior to commissioning, oil refilling should be made. Any manipulation of the equipment at a temperature below  $-25\text{ }^{\circ}\text{C}$  is forbidden. Storing the actuator out of doors or at a location that is not protected against the effects of rain, snow or ice accretion should be avoided. Before putting the actuator into operation, excessive slush should be removed. When unpacked actuators are to be stored longer than 3 months it is advisable to place a bag with silica gel or another suitable desiccant in the terminal box.

## CHECKING OF THE INSTRUMENT FUNCTION AND ITS LOCATION

Prior to installation, be sure that the actuator was not damaged during storing. A functional check of the electric-motor can be made so that it is connected to the AC mains via a circuit breaker and started for short-time operation. In this case, it is sufficient to check that the electric motor starts and turns the output shaft.

The actuator should be installed so that easy access to the handwheel, the terminal box and the control box is provided. It is also imperative to check that the installation complies with the Clause „Operating Conditions“. If another method of installation is required due to local conditions, please consult the manufacturer.

## ATTACHMENT TO A VALVE

Place the actuator on the valve so that its output pull-rod can be connected to the output pull-rod of the valve. Attach the actuator to the valve and check the attachment by rotating the handwheel. Remove the terminal box cover and wire the actuator, according to the internal and external circuit layouts.

## ADJUSTMENT OF THE ACTUATOR WITH A VALVE

After fitting the actuator on the valve and checking mechanical connection, the assembly is set up and adjusted.

Setting-up and adjustment can only be carried out by a person with prescribed qualification. These works may not be carried out without properly studying these assembly instructions. Adjustment is accomplished according to instructions for the given type of electronics (DMS2, DMS2 ED) and outfit (manual, program).

## OPERATION AND MAINTENANCE

Depending on the operating conditions, the operation of rectilinear actuators usually involves only the transmission of pulses, as required for the individual functions. In the event of a power supply failure, readjust the controlled device by the handwheel. If the actuator has been connected in the circuit of automatic equipment (which does not imply the control mode), it is advisable that manual remote control units are connected in the circuit so that the actuator can be controlled even if a failure of the automatic equipment occurs. It is the operator's duty to ensure that the actuator is given the specified maintenance attention and is protected against the harmful effects of ambient and climatic conditions not included in the Clause „Operating conditions“.

The actuators are lubricated with plastic consistent lubricants. The types of lubricant and amounts are listed in the table.

For lubrication of drive units use plastic consistent lubricants.

Lubricants in the drive units supplied are designed to last the entire useful life of the unit.

During the time when the drive units are in use, it is not necessary to change or monitor the amount of the lubricant.

The actuators with plastic lubricant are labelled „Filled: solid grease“ on the power box at the side of the hand-wheel.

Type number of drive unit	Amount of lubricant (kg)	Type of lubricant for specific climatic conditions and temperature		
		T1 (-25 – +70 °C)	U1 (-40 – +55 °C)	UChL1 (-50 – +55 °C)
52 442	0,30	CIATIM – 201 GOST 6267-74 CIATIM – 221 GOST 9433-80		
52 443	0,50			

**Note:** The Ciatim 221 lubricant is designed for the friction points of rubber bushings against metal surfaces, roller brake, the hub of an outer cogged wheel of a planetary-gear differential of actuators 52 442 (for locations of friction between the shaft and other surfaces).

Moreover, the rectilinear mechanism 11 (Fig. 1) should be greased yearly. For this purpose, force about 50 g of grease MOGUL LV 2-EP into grease box 12 of the rectilinear mechanism (Fig. 1). The threads of the nut and the spindle are also greased with MOGUL LV 2-EP so that the upper tightening strip or ring of dust seal 13 (Fig. 1) is released. After removal of the dust seal, the threads should be greased through the gap that has been thereby disclosed. This procedure should be made with the pull-rod in the CLOSED position.

## FAILURES AND THEIR REMOVAL

The actuator is in its limit position and does not start; the motor hums. Make a check for possible interrupted phase.

If the valve is wedged and cannot be moved using the hand wheel or motor, dismantle the actuator and release the closure mechanically.

### Cleaning - general inspection

The electric actuators should be kept clean and attention should be paid to prevent their clogging with dirt and dust. Cleaning should be carried out regularly and as often as required by operation conditions. Occasionally, it is necessary to make sure that all connecting and earthing terminals are properly tightened in order to prevent their heating during operation. The general inspection of the actuator is recommended once in 4 operating years unless otherwise specified in the revision regulations of electric devices.

**List of spare parts of MODACT MTNED, MTPED actuators**  
(for 5 years of operation)

	Designation	Drawing or ČSN Standard No.		Application
52442	Sealing ring 125x3	PN 02 9281.2	1	Packing between power gear box and flange with gears
	Sealing ring 130x3	PN 02 9281.2	1	Packing between control box and power gear box
	Sealing ring 43x35	PN 02 9280.2	1	Sealing of output shaft in the control box
	Sealing ring 170x3	PN 02 9280.2	1	Sealing of control box cover
	Rotary shaft seal 40x52x7	ČSN 02 9401.0	1	Sealing of output shaft in the control box
	Rotary shaft seal 40x52x7	ČSN 02 9401.0	2	Sealing of output shaft in the power gear box
	Rotary shaft seal 16x28x7	ČSN 02 9401.2	1	Sealing of handwheel shaft
52 443	Sealing ring 160x3	PN 02 9281.2	1	Packing between power gear box and flange with gears
	Rotary shaft seal 20x32x7	ČSN 02 9401.0	1	Sealing of handwheel shaft
	Sealing ring 95x85	PN 02 9280.2	1	Packing of the rubber-copper sealing ring in the power box
	Sealing ring 50x2	PN 02 9281.0	1	Sealing of torque-limit switching spring cover
	Rotary shaft seal 60x75x8	ČSN 02 9401.0	2	Sealing of output shaft in the power gear box
	Sealing ring 190x3	PN 02 9280.2	1	Packing between control box and power gear box
	Rotary shaft seal 55x70x8	ČSN 02 9401.2	1	Sealing of output shaft in the control box
	Sealing ring 60x50	PN 02 9280.2	1	Sealing of output shaft in the control box cover
	Sealing ring 190x3	PN 02 9281.0		Sealing of control box cover
	52 442 + 52 443	Packing 16x22	224580840	2
Sealing ring 125x5		P 02 9281.2	1	Packing between control box and terminal box
Packing		52 442 - 224591870	1	Packing between electric motor and flange with gears
		52 443 - 224642240	1	
Microswitch CHERRY D - 433 - B8LD			1	CLOSE signalling switch (SZ)
			1	OPEN signalling switch (SO)
Microswitch CHERRY D - 433 - B8LD			1	CLOSE position-limit switch (PZ)
			1	OPEN position-limit switch (PO)
Microswitch SAIA XGK 12-88-J21			1	CLOSE torque-limit switch (MZ)
			1	OPEN torque-limit switch (MO)
Sealing ring 180x3		PN 02 9281.2	1	Packing of terminal box cover
Sealing ring 32x2		PN 02 9281.2	1	Packing of inspection hole of local position indicator
Inspection hole		4 - 62847	1	Local position indicator cover
Sealing ring 10x6	PN 02 9280.2	2	Packing of torque-limit switching shaft	

<b>Actuators fitted with electronics DMS2 ED</b>			
<b>Part name</b>	<b>Part designation</b>	<b>Stock item</b>	<b>Note</b>
Source board	DMS2.ED.Z	39620000	
Position sensor multi-revolution	DMS2.ED.S	39620001	
Torque sensor	DMS2.TORK	39620003	common for DMS2.ED and DMS2
Analog module	DMS.ED.CPT	39620004	back signal 4 – 20 mA and software blocked regulator
Display	DMS2.ED.D	39620005	
<b>Actuators fitted with electronics DMS2</b>			
Source board analog	DMS2.ZAN	39620014	only for analog
Source board Profibus	DMS2.ZPR	39620015	only for Profibus version
Position sensor multi-revolution	DMS2.S	39620016	
Torque sensor	DMS2.TORK	39620003	common for DMS2.ED and DMS2
Display	DMS2.DP	39620018	
Board of local control block	DMS2.H1	39620019	
<b>Dynamic brakes (for actuators with electronics DMS2 ED a DMS2)</b>			
Brake	BR2 550	2339610124	
Brake	BR2 BK 550	2339610128	
Brake	BR 2,2	2339610142	
Brake	BR BK 2,2	2339610141	
Braking resistance	TR342 68R	2337110355	

A setting program is available for the actuators (it is described in these Assembly Instructions); it enables the parameters of the electronic outfit of the actuators to be set and checked by a computer.

The electronics is connected to the serial port of the computer by a cable (it is available e.g. under the name "Extending cable for mouse 9F-9M").

In case the computer is not fitted with a serial port the converter USB-RS 232, can be ordered.



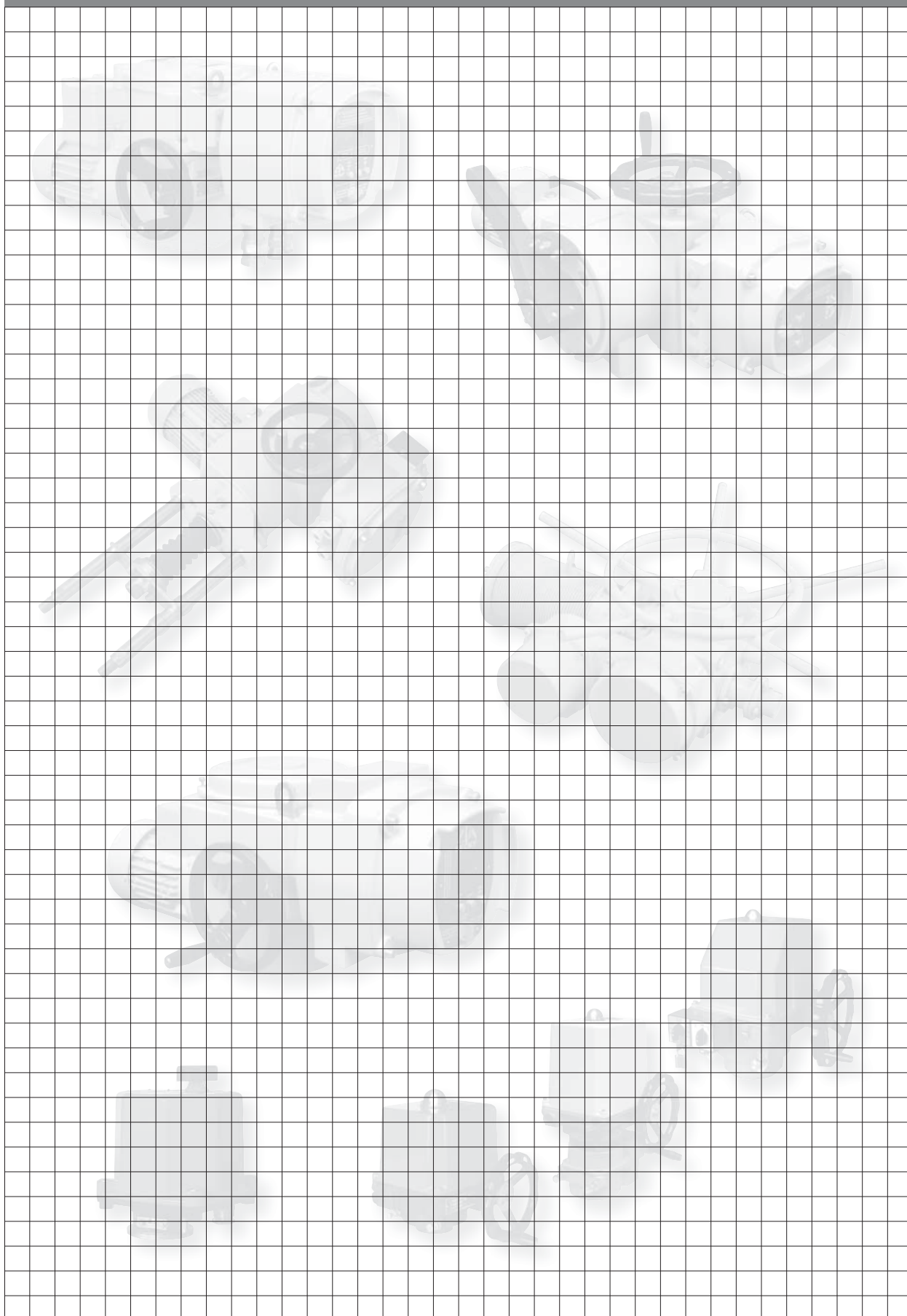

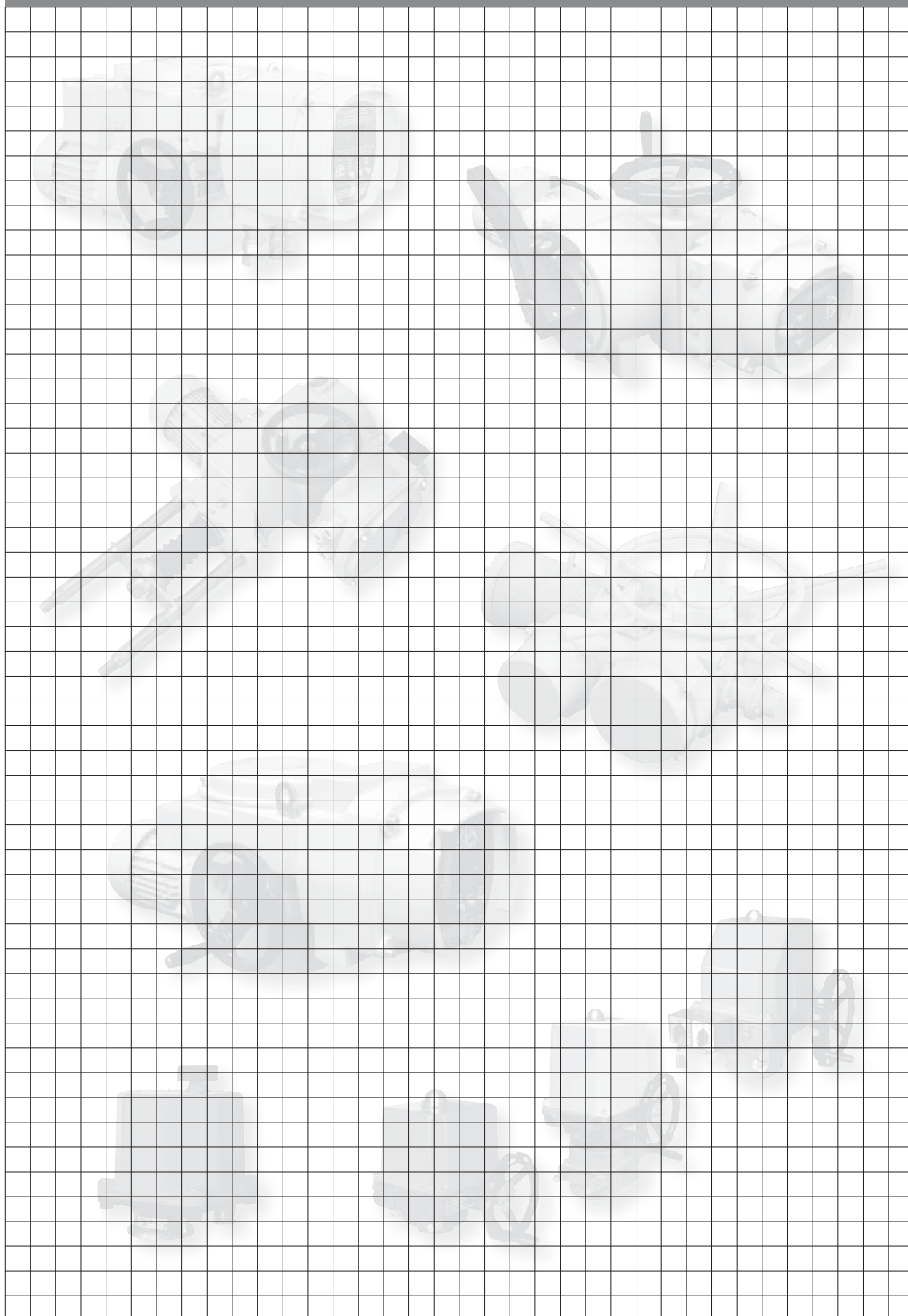



Development, production and services of electric actuators and switchboards.  
Top-quality sheet-metal processing (TRUMPF equipment), powder paint shop.

## SURVEY OF PRODUCED ACTUATORS

### **KP MINI, KP MIDI**

Electric rotary (90°) actuators (up to 30 Nm)

### **MODACT MOK, MOKED, MOKP Ex**

Electric rotary (90°) actuators for ball valves and flaps

### **MODACT MOKA**

Electric rotary (90°) actuators for nuclear power stations  
application outside containment

### **MODACT MONJ, MON, MOP, MONED, MONEDJ, MOPED**

Electric rotary multi-turn actuators

### **MODACT MO EEx, MOED EEx**

Explosion proof electric multi-turn actuators

### **MODACT MOA**

Electric multi-turn actuators for nuclear power stations  
application outside containment

### **MODACT MOA OC**

Electric multi-turn actuators for nuclear power stations  
application inside containment

### **MODACT MPR Variant**

Electric rotary (160°) lever actuators with a variable output speed

### **MODACT MPS Konstant, MPSED**

Electric rotary (160°) lever actuators with a constant output speed

### **MODACT MTN, MTP, MTNED, MTPED**

Electric linear thrust actuators with a constant output speed

---

Deliveries of assembled actuator + valve (or MASTERGEAR gearbox) combinations

---

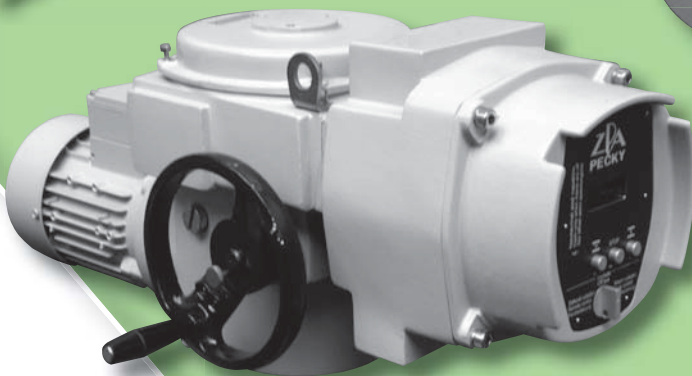
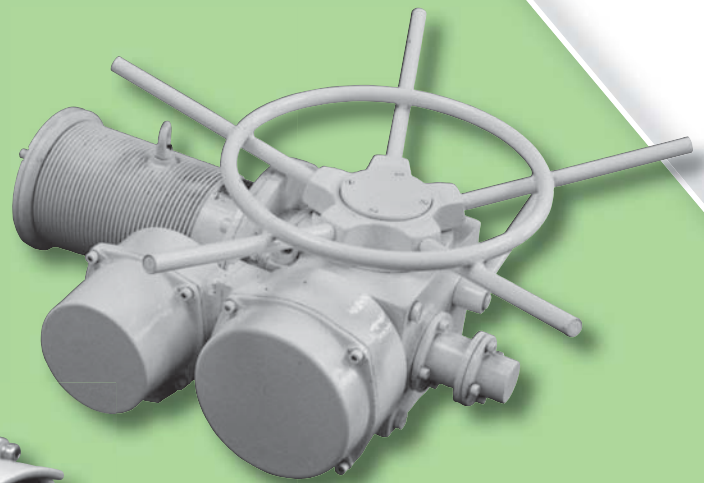
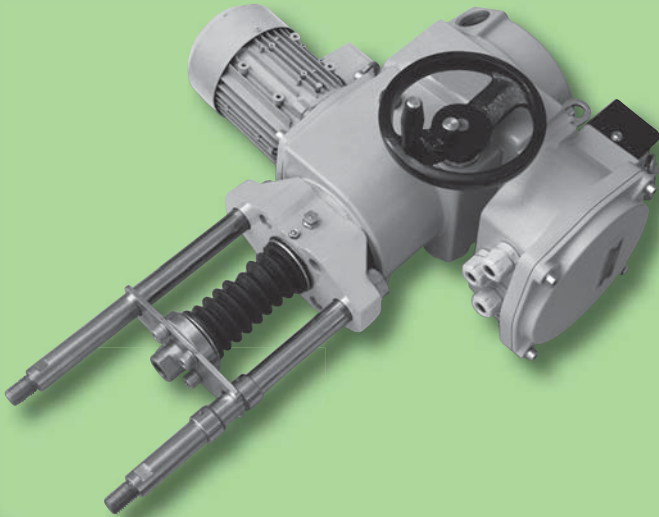
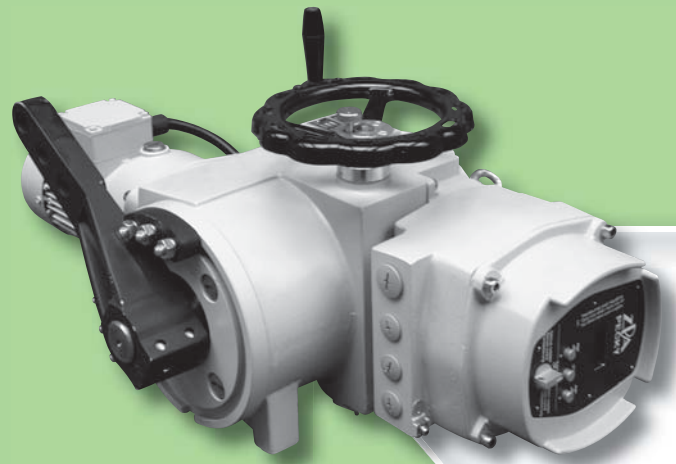
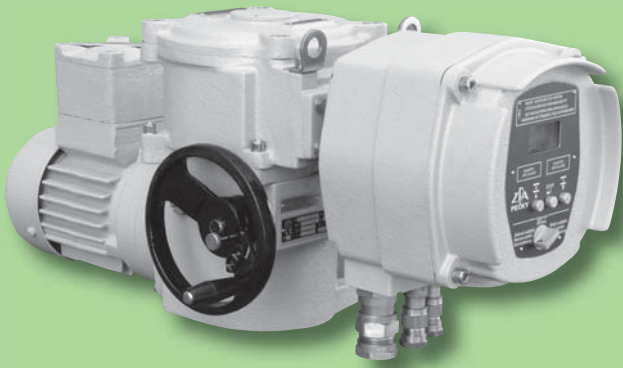

ZPA Pečky, a.s.  
tř. 5. května 166  
289 11 PEČKY, Czech Republic  
[www.zpa-pecky.cz](http://www.zpa-pecky.cz)

  
EN ISO 9001:2000  
Certificate No. 04 100 950 161

tel.: +420 321 785 141-9  
fax: +420 321 785 165  
+420 321 785 167  
e-mail: [zpa@zpa-pecky.cz](mailto:zpa@zpa-pecky.cz)